

Bettis GVO LP DA/SR Series

Double-Acting and Spring-Return Pneumatic Actuators

Double-acting and single acting pneumatic linear actuators for ON-OFF and regulating service.



This page intentionally left blank.

Table of Contents

Section 1: General Application	
General Application	5
Section 2: Technical Data	
Technical Data	5
Section 3: Features	
Features	5
Section 4: Approvals	
Approvals	5
Section 5: Actuator Main Options	
Actuator Main Options	7
Section 6: Bettis GVO LP SR Spring-Return Actuator	
Bettis GVO LP SR Spring-Return Actuator.....	8
Section 7: Bettis GVO LP DA/SR Series	
Selection Guide	9

This page intentionally left blank.

General Application

Bettis GVO LP pneumatic actuators are designed for the automation of gate, globe and all other linear valves.

Technical Data

Design pressure (MAWP):	According to customer specification (max. 12 barg) Contact factory
Supply medium:	Air, nitrogen or sweet gas Sour gas version available
Output thrust:	
Bettis GVO LP DA:	Double-acting thrust up to 1600000 N / 360000 lb
Bettis GVO LP SR:	Spring ending thrust up to 450000 N / 101000 lb Spring starting thrust 540000 N / 121000 lb
Ambient temperature:	From -60 to 100 °C / -76 to 212 °F
Multi-spring version available on request.	
MAWP:	Maximum Allowable Working Pressure is the pressure defined for the design of the actuator pressure containing parts.
MOP:	Maximum Operating Pressure is the pressure that generates the torque used to engineer the mechanical loaded parts of the actuator and it is the one required to produce the Maximum Operating Torque (MOT) of the actuator.

Features

- Electroless nickel plated and polished cylinder for corrosion resistance and minimal friction.
- Hard chromium plated and polished piston rod in stainless steel for corrosion resistance and minimum friction.
- Piston rod support bushing in bronze with sintered Polytetrafluoroethylene (PTFE) provides minimal friction and extended service life.
- Bettis GVO LP SR totally enclosed spring cartridge ensures personnel safety during assembly or disassembly.
- Compact design available to allow space footprint reduction without reducing requested thrust value.
- Fabricated carbon steel adapter spool with accessories provision designed specifically for adaptation to any type of valve.
- Accept an extensive range of accessories:
 - Complete control panel
 - Emergency tank
 - Manual handpump
 - Partial Stroke Test (PST) device
- Special coatings for offshore or corrosive environments.
- Special versions with built-in dump valve and damper for “quick spring operation”.
- Double cylinder available to increase output capability.
- Housing in painted carbon steel.
- Spool in painted carbon steel or unpainted SS316 as option.

Approvals

Safety Integrity Level:	IEC61508 -1 ÷ 7 2010 Suitable for use in SIL 3 applications
Area Classifications:	(ATEX) II2GD
Enclosure Standard:	(IEC60529)-IP67M ANSI/NEMA250 NEMA 4-4X-6
Pressure Equipment Directive:	2014/68/UE
Machinery Directive:	2006/42/EC

The following technical information is necessary in order to efficiently select a Bettis GVO LP DA or SR linear actuator. The thrust table contained in this document represents only an example of the available product range. Please send a request for quotation to your local Emerson sales office.

Table 1.

Type of valve
Solid wedge
Flexible wedge
Slab gate
Expanding gate
Globe (flow closes)
Globe (flow opens)
Ball (e.g., Orbit)
Others
Stem movement required for closing (*)
Rising valve stem (UPWARDS)
Reverse acting
Descending valve stem (DOWNWARDS)
Direct acting
Required Thrust (*)
Break to Open (BTO)
Running to Open (RTO)
End to Open (ETO)
Break to Close (BTC)
Running to Close (RTC)
End to Close (ETC)
Max. acceptable stem thrust CLOSING
Max. acceptable stem thrust OPENING
Units of measure
Actuator to stop (*)
OPEN position
By THRUST
In POSITION
CLOSE position
By THRUST
In POSITION
Valve total stroke (*)
Units of measure
Minimum BTO/ETC ratio (if required)
Safety factor to be applied to declared thrust values (*)

Actuator supply pressure (*)
Minimum
Normal
Maximum
Units of measure
Actuator fed medium
Air/Sweet gas
Oil
Sour gas (ppm of H ₂ S)
Type of actuator (*)
Double-acting
Spring-return
Spring action (if applicable) (*)
Close
Open
Failure mode on loss of medium pressure power
Close
Open
Last
Failure mode on loss of control signal
Close
Open
Last
Manual Override
Not required
Jackscrew type
Hydraulic with handpump
Type of valve

NOTE:
* Mandatory data

Actuator Main Options

MHP Hydraulic Manual Override

The MHP hydraulic manual override is used to manually operate the actuator in lack of air supply. It also allows to accurately adjust the actuator operating times, independently in opening and in closing, by way of the hydraulic regulators which work on the oil flow from one chamber to the other of the hydraulic cylinder during pneumatic operation. Moreover, it permits a smooth angular speed all along the stroke.

Figure 1.

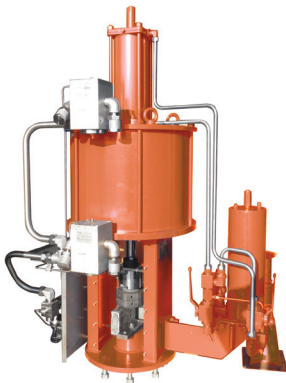

MHW Manual Handwheel (Option)

The handwheel manual override is mounted on the end flange of the pneumatic cylinder and consists of a jackscrew which is screwed into the bronze screw nut mounted in the cylinder end flange.

Mounting Interface

The mounting interface is customizable according to the valve top mounting and control accessories requirements.

Figure 2.

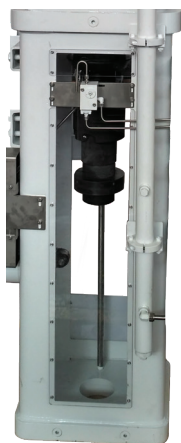

Accessories

Bettis linear valve actuators can be supplied as a basic actuator or can be configured with various control accessories and related features.

Figure 3.



Quick acting version

Special configuration for fast fail action with the IQEV.

Figure 4.

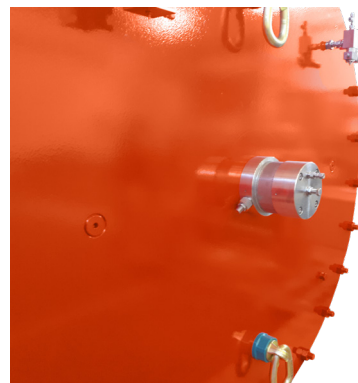

Bettis GVO LP SR Spring-Return Actuator

Figure 5.

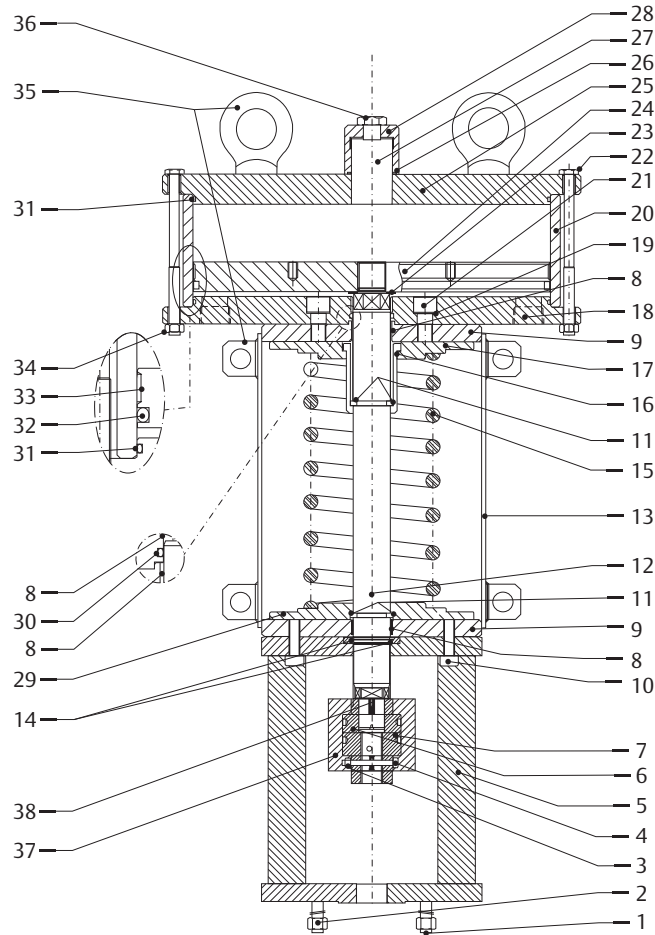

Table 2. Parts List

Item	Description
1	Stud bolt
2	Nut
3	Nut
4	Screw
5	Pedestal
6	Actuator joint
7	Stem valve joint
8	Bushing
9	Flange
10	Screw
11	Retainer ring
12	Piston rod
13	External tube
14	Scraper ring with support
15	Internal spring
16	Piston rod guide tube
17	Upper spring flange
18	Head flange
19	Seal washer

Item	Description
20	Cylinder tube
21	Screw
22	Screw
23	Connecting device
24	Piston
25	End flange
26	O-ring
27	Adjusting screw
28	Adjusting screw cover
29	Lower spring flange
30	O-ring
31	O-ring
32	O-ring
33	Guide sliding piston ring
34	Nut
35	Eyebolt
36	Plug for adj. screw cover
37	Shell joint
38	Spacer

Bettis GVO LP DA/SR Series Selection Guide

Table 3. Pneumatic Double-Acting Actuator

Example		GVO LP	250k	135	300	MHP/MHW
GVO LP DA	Actuator series					
250K	Max. allowable thrust (N)					
135	Cylinder diameter (mm)					
300	Stroke (mm)					
MHP	Manual override					

Table 4. Pneumatic Spring-Return Actuator

Example		GVO LP	250k	135	100K	CL	300	MHP/MHW
GVO LP SR	Actuator series							
250K	Max. allowable thrust (N)							
135	Cylinder diameter (mm)							
100K	Spring ending thrust (N)							
CL	Spring action							
300	Stroke (mm)							
MHP	Manual override							

www.emerson.com/bettis

VCPDS-16002-EN (CP-16072) © 2023 Emerson. All rights reserved.

The Emerson logo is a trademark and service mark of Emerson Electric Co. Bettis™ is a mark of one of the Emerson family of companies. All other marks are property of their respective owners.

The contents of this publication are presented for informational purposes only, and while every effort has been made to ensure their accuracy, they are not to be construed as warranties or guarantees, express or implied, regarding the products or services described herein or their use or applicability. All sales are governed by our terms and conditions, which are available upon request. We reserve the right to modify or improve the designs or specifications of such products at any time without notice.

BETTIS™

