



## AEV<sup>2</sup>XC C-BALL VALVES - CRITICAL SERVICE APPLICATIONS

With its breakthrough “C” shaped ball design, the <sup>2</sup>XC ball valve delivers superior reliability and isolation with improved safety and performance.



### FEATURES

- Designed to ASME B16.34, API 608, API 6D
- Metal-to-metal seating to handle critical service applications
- Double eccentric motion removes continuous rubbing action between Ball and Seat most of 90° of travel
- Fixed seat design eliminates fouling issues (Particle stuck between seat and spring, O-Ring, Lip-Seal)
- Fully protected Trunnion for abrasive media (Optional Feature)
- Fully hardened valve Ball and Seat surface
- Fugitive emissions certified to ISO 15848-1
- Fire test certified to API 607 and ISO 10497
- ISO 5211 actuator mounting pad
- Material complies to NACE MR0175 / ISO 15156 or MR0103 traceability available upon request
- Manufactured under ISO 9001 certified quality system
- CE marking PED 2014/68/EU available
- SIL 3 Certified for product safety performance
- Various seat options to meet a wide range of performance criteria to suit a variety of applications: Stellite®, Tungsten Carbide, Chrome Carbide etc.

### NOTES

Drawings and dimensional tables published in this datasheet represent a selection from a much wider range available. For more information, please contact your nearest Emerson sales office.

**\* Please consult the factory for sizes up to 42 inch.**

### GENERAL APPLICATION

- Molecular sieve
- Polymers
- Fouling service
- Molten fluids
- High Integrity Pressure Protection Systems
- Emergency Shutdown (ESD)
- Powder service
- Decoking service
- Isolation and shutoff applications

### TECHNICAL DATA

Sizes: DN 15 - 750 / NPS 1/2 - 30\*

Pressure rating: ANSI Class 150 - 4500; EN PN 10 - 400

Temperature Range: -196 to 538°C / -320 to 1000°F

#### Standards

##### Design:

ASME B16.34, API 6D, API 608

**Face-to-Face:** ASME B16.10

##### End Connections:

Flange: ASME B16.5 / ASME B16.47; EN 1092-1

BW: B 16.25 / EN 12224

SW / Threaded: B 16.11 / EN 10241

# AEV 2XC C-BALL VALVES - CRITICAL SERVICE APPLICATIONS

## DESIGN FEATURES

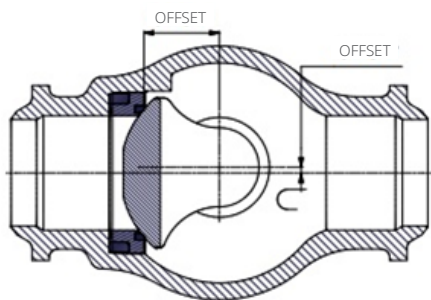

### Double Eccentric Design

The double eccentric motion generates a "cam motion," resulting in a non-rubbing design where the ball and seat do not experience continuous contact for most of 90 degrees travel. This design is inherently robust, making it ideal for cycling applications and critical service applications.



### Fully Hard Coated C-Ball and Seat

C-Ball and Seat are fully surface hardened, ensuring exceptional durability and dependability. Advanced coating provides enhanced protection and significantly reduces the occurrence of erosive damage, making the valve highly suitable and reliable for critical service applications.

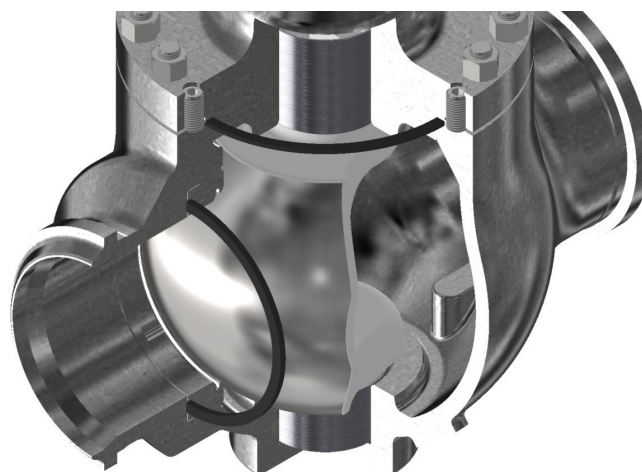

Traditional Ball Valve



AEV C-Ball Design

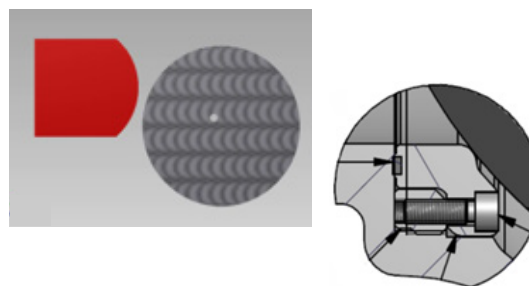

### Fixed Seat Design for Superior Performance

Seat is fixed in place with a static gasket vs floating seat with spring and dynamic seal in traditional ball valve. Static seat to body seal simplifies design eliminating dynamic seals for greater reliability, improved performance and safety.

### Convex to Convex Sealing Design

Sweeping particles away instead of pressing them against the valve seat, the design prevents particles from getting trapped between the seat and ball.

# AEV 2XC C-BALL VALVES - CRITICAL SERVICE APPLICATIONS

## BASIC CONFIGURATION SECTIONAL DRAWING

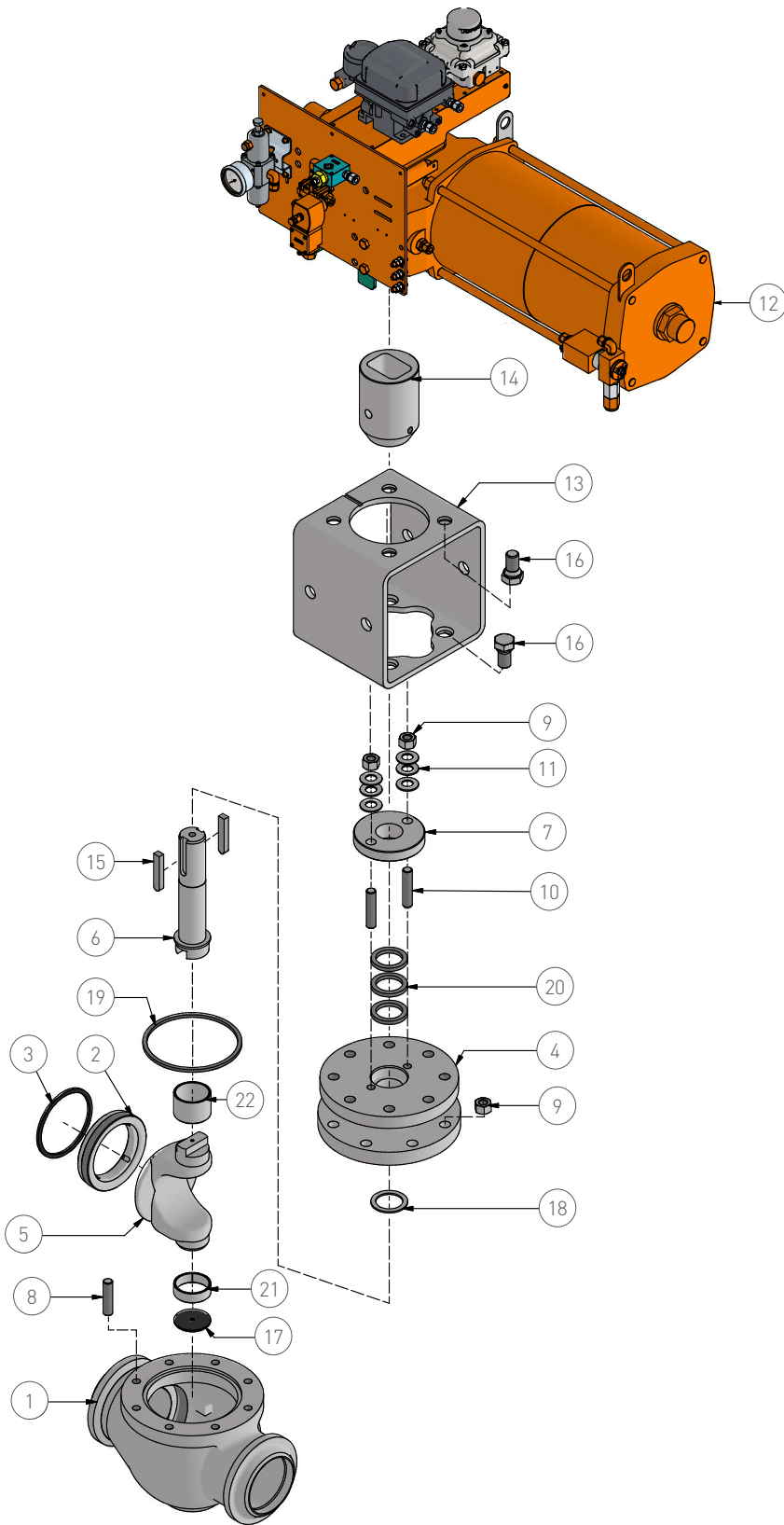

Item	Description	Qty
1	Body	1
2	Seat Ring	1
3	Gasket Seat	1
4	Bonnet	1
5	C-Ball	1
6	Stem	1
7	Packing Flange	1
8	Stud	8
9	Nut	10
10	Stud	2
11	Spring Washer	1 set
12	Actuator	1
13	Bracket	1
14	Adaptor	1
15	Key	2
16	Screw	8
17	Ball Support	1
18	Stem Bearing	1
19	Gasket	1
20	Packing Ring	3
21	Bottom Tr. Bearing	1
22	Top Tr. Bearing	1

### NOTE

AEV C-Ball Valve shown is representative, and the quantities mentioned are for illustrative purposes only.

# AEV 2XC C-BALL VALVES - CRITICAL SERVICE APPLICATIONS

## TYPICAL MATERIAL SELECTION

Typical Material Selection - Please refer to basic configuration sectional drawing on page 3.

Parts Description	Variant 1	Variant 2	Variant 3
Body	Stainless Steel <sup>(1)</sup>	Carbon Steel <sup>(2)</sup>	Low temperature carbon steel <sup>(3)</sup>
Seat		UNS S31600 + HF <sup>(4)</sup>	
Gasket Seat		Graphite	
Bonnet		Same as body	
C-Ball		ASTM A351 CF8M + HF <sup>(4)</sup>	
Stem		UNS S31600 / UNS S31600 CD / XM-19 (UNS S20910)	
Packing Flange		Same as body	
Stud	ASTM A320 B8M CL.2	ASTM A193 B7 (M)	ASTM A320 L7 (M)
Nut	ASTM A194 8M	ASTM A194 2H (M)	ASTM A194 7 (M)
Gear		Cast Iron	
Handwheel		Carbon Steel	
Bracket		Stainless steel - Carbon steel	
Key		AISI 316	
Screw		Stainless Steel A4	
Screw		Stainless Steel A4	
Stabilization Screw		Stainless Steel A4	
Pin		Same as stem	
Ball Support		AISI 316 Coated	
Stem Bearing		AISI 316 Coated	
Bottom Tr. Bearing		AISI 316 Coated - Nitronic 60 - Dual AISI 316 + Kolsterising <sup>(5)</sup>	
Top Tr. Bearing		AISI 316 Coated - Nitronic 60 - Dual AISI 316 + Kolsterising <sup>(5)</sup>	
Gasket Seat		SPW AISI 316 / Graphite - Graphite	
Packing Ring		Graphite <sup>(6)</sup>	

### NOTES

1. Stainless steel: ASTM A351 CF3M, ASTM A351 CF8M, ASTM A995 4A, ASTM A351 CF3, ASTM A351 CF8
2. Carbon steel: ASTM A216 WCB, ASTM A216 WCC
3. Low temperature Carbon steel: ASTM A352 LCB, ASTM A352 LCC
4. HF: CCC-S (Chrome Carbide HVOF on Ball / Stellite® 12 on Seat), TCC-S (Tungsten Carbide HVOF on Ball / Tungsten Carbide HVOF on Seat)
5. Dual AISI 316 + Kolsterising: Special High Cycling Bearing
6. Live loaded packing available in option

# AEV 2XC C-BALL VALVES - CRITICAL SERVICE APPLICATIONS

## DIMENSIONS AND WEIGHTS / ASME CLASS 150 - BW END CONNECTIONS

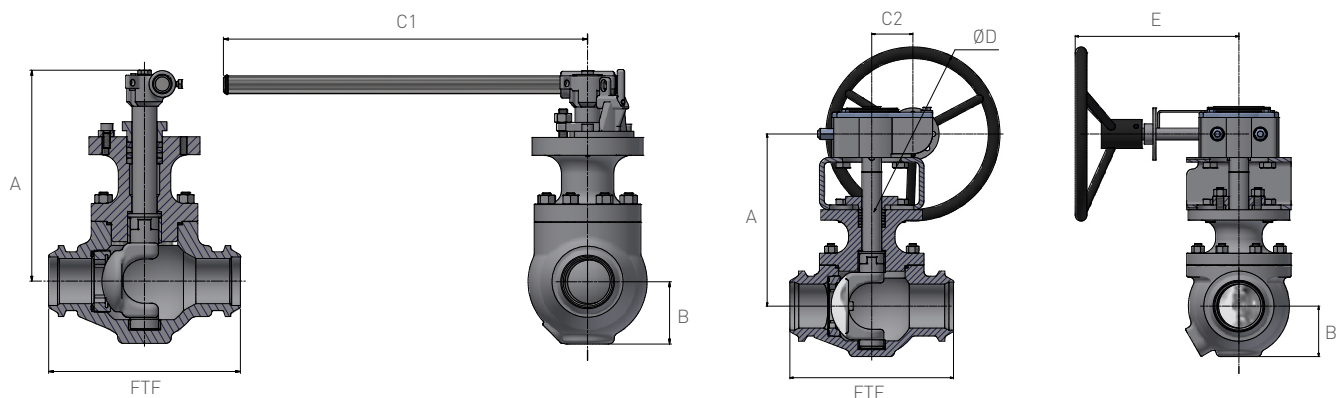

Lever Operated  
 Sizes DN 15 - 50 / NPS 1/2 - 2

Handwheel Operated  
 Sizes DN 65 - 600 / NPS 2 1/2 - 24

### ASME CLASS 150 DIMENSIONS mm

Size in	Full Bore								Reduced Bore							
DN	FTF	A	B	C1	C2	ØD	E	Weight kg	FTF	A	B	C1	C2	ØD	E	Weight kg
15	140	172	36	245	-	-	-	7	-	-	-	-	-	-	-	-
20	152	172	45	330	-	-	-	7	-	-	-	-	-	-	-	-
25	165	172	45	330	-	-	-	8	-	-	-	-	-	-	-	-
40	190	209	68	330	-	-	-	14	-	-	-	-	-	-	-	-
50	216	209	70	410	-	-	-	14	-	-	-	-	-	-	-	-
65	241	250	85	-	71	300	282	30	241	200	70	-	52	300	254	25
80	282	300	87	-	71	300	282	50	283	250	70	-	52	300	254	30
100	305	385	122	-	86	400	286	86	305	300	90	-	71	300	282	55
150	457	426	179	-	105	400	409	165	457	385	130	-	86	500	309	110
200	521	450	215	-	130	500	418	250	521	426	183	-	105	400	409	150
250	559	475	260	-	182	600	470	452	559	450	215	-	130	500	447	355
300	635	550	300	-	182	600	470	645	635	475	260	-	182	600	470	350
350	762	640	340	-	209	600	491	760	762	550	300	-	182	600	470	665
400	838	650	380	-	209	600	491	950	838	640	340	-	209	600	491	785
450	914	800	421	-	209	600	491	1330	914	650	380	-	209	600	491	1095
500	991	840	490	-	209	600	491	2185	991	800	421	-	256	700	541	1970
600	1143	900	560	-	256	700	541	2500	1143	840	490	-	256	700	541	2015

### ASME CLASS 150 DIMENSIONS inch

Size in	Full Bore								Reduced Bore							
NPS	FTF	A	B	C1	C2	ØD	E	Weight lbs	FTF	A	B	C1	C2	ØD	E	Weight lbs
1/2	5.51	6.77	1.42	9.65	-	-	-	15	-	-	-	-	-	-	-	-
3/4	5.98	6.77	1.77	12.99	-	-	-	15	-	-	-	-	-	-	-	-
1	6.50	6.77	1.77	12.99	-	-	-	18	-	-	-	-	-	-	-	-
1 1/2	7.48	8.23	2.68	12.99	-	-	-	31	-	-	-	-	-	-	-	-
2	8.50	8.23	2.76	16.14	-	-	-	31	-	-	-	-	-	-	-	-
2 1/2	9.49	9.84	3.35	-	2.80	11.81	11.10	66	9.49	7.87	2.76	-	2.05	11.81	10.00	55
3	11.10	11.81	3.43	-	2.80	11.81	11.10	110	11.14	9.84	2.76	-	2.05	11.81	10.00	66
4	12.01	15.16	4.80	-	3.39	15.75	11.26	190	12.01	11.81	3.54	-	2.80	11.81	11.10	121
6	17.99	16.77	7.05	-	4.13	15.75	16.10	364	17.99	15.16	5.12	-	3.39	19.69	12.17	243
8	20.51	17.72	8.46	-	5.12	19.69	16.46	552	20.51	16.77	7.20	-	4.13	15.75	16.10	331
10	22.01	18.70	10.24	-	7.17	23.62	18.50	998	22.01	17.72	8.46	-	5.12	19.69	17.60	784
12	25.00	21.65	11.81	-	7.17	23.62	18.50	1424	25.00	18.70	10.24	-	7.17	23.62	18.50	773
14	30.00	25.20	13.39	-	8.23	23.62	19.33	1678	30.00	21.65	11.81	-	7.17	23.62	18.50	1468
16	32.99	25.59	14.96	-	8.23	23.62	19.33	2097	32.99	25.20	13.39	-	8.23	23.62	19.33	1733
18	35.98	31.50	16.57	-	8.23	23.62	19.33	2936	35.98	25.59	14.96	-	8.23	23.62	19.33	2417
20	39.02	33.07	19.29	-	8.23	23.62	19.33	4823	39.02	31.50	16.57	-	10.08	27.56	21.30	4349
24	45.00	35.43	22.05	-	10.08	27.56	21.30	5519	45.00	33.07	19.29	-	10.08	27.56	21.30	4448

#### NOTE

Please consult factory for sizes above 24 in.

# AEV<sup>2</sup>XC C-BALL VALVES - CRITICAL SERVICE APPLICATIONS

## DIMENSIONS AND WEIGHTS / ASME CLASS 150 - FLANGED END CONNECTIONS

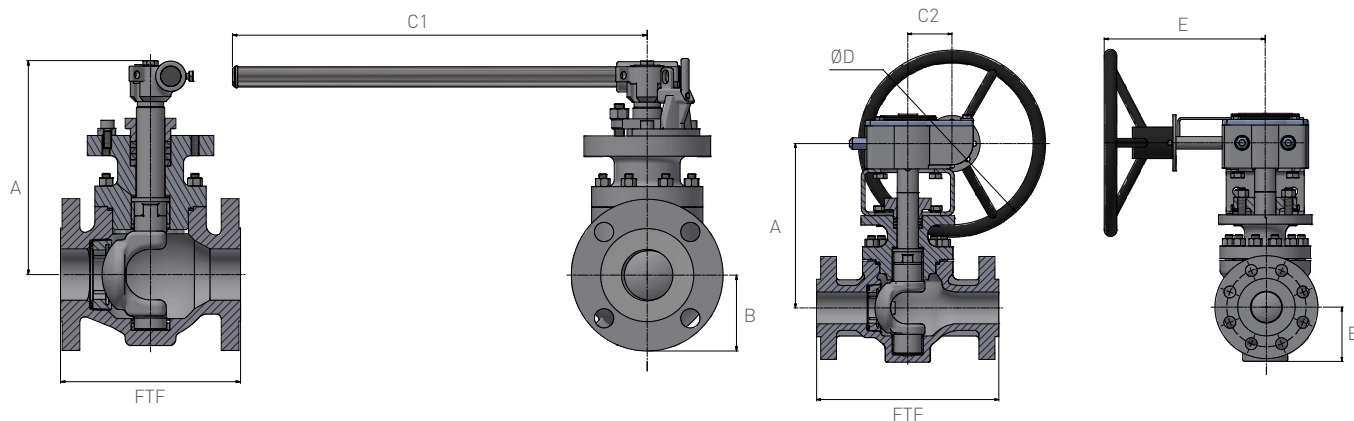

Lever Operated  
 Sizes DN 15 - 50 / NPS 1/2 - 2

Handwheel Operated  
 Sizes DN 65 - 600 / NPS 2 1/2 - 24

### ASME CLASS 150 DIMENSIONS mm

Size in	Full Bore								Reduced Bore							
DN	FTF	A	B	C1	C2	ØD	E	Weight kg	FTF	A	B	C1	C2	ØD	E	Weight kg
15	108	172	45	245	-	-	-	7	-	-	-	-	-	-	-	-
20	117	172	50	330	-	-	-	7	-	-	-	-	-	-	-	-
25	127	172	54	330	-	-	-	8	-	-	-	-	-	-	-	-
40	165	209	68	330	-	-	-	14	-	-	-	-	-	-	-	-
50	178	209	75	410	-	-	-	14	-	-	-	-	-	-	-	-
65	190	250	90	-	71	300	282	30	190	200	90	-	52	300	254	25
80	203	300	95	-	71	300	282	50	203	250	95	-	52	300	254	30
100	229	385	122	-	86	400	286	86	229	300	115	-	71	300	282	48
150	394	426	179	-	105	400	409	165	394	385	140	-	86	500	309	110
200	457	450	215	-	130	500	418	250	457	426	183	-	105	400	409	150
250	533	475	260	-	182	600	470	452	533	450	215	-	130	500	447	300
300	610	550	300	-	182	600	470	645	610	475	260	-	182	600	470	400
350	686	640	340	-	209	600	491	760	686	550	300	-	182	600	470	665
400	762	650	380	-	209	600	491	950	762	640	340	-	209	600	491	785
450	864	800	421	-	209	600	491	1330	864	650	380	-	209	600	491	1095
500	914	840	490	-	209	600	491	2185	914	800	421	-	256	700	541	1970
600	1067	900	560	-	256	700	541	2800	1143	840	490	-	256	700	541	2015

### ASME CLASS 150 DIMENSIONS inch

Size in	Full Bore								Reduced Bore							
NPS	FTF	A	B	C1	C2	ØD	E	Weight lbs	FTF	A	B	C1	C2	ØD	E	Weight lbs
1/2	4.25	6.77	1.77	9.65	-	-	-	15	-	-	-	-	-	-	-	-
3/4	4.61	6.77	1.97	12.99	-	-	-	15	-	-	-	-	-	-	-	-
1	5.00	6.77	2.13	12.99	-	-	-	18	-	-	-	-	-	-	-	-
1 1/2	6.50	8.23	2.68	12.99	-	-	-	31	-	-	-	-	-	-	-	-
2	7.01	8.23	2.95	16.14	-	-	-	31	-	-	-	-	-	-	-	-
2 1/2	7.48	9.84	3.54	-	2.80	11.81	11.10	66	7.48	7.87	3.54	-	2.05	11.81	10.00	55
3	7.99	11.81	3.74	-	2.80	11.81	11.10	110	7.99	9.84	3.74	-	2.05	11.81	10.00	66
4	9.02	15.16	4.80	-	3.39	15.75	11.26	190	9.02	11.81	4.53	-	2.80	11.81	11.10	106
6	15.51	16.77	7.05	-	4.13	15.75	16.10	364	15.51	15.16	5.51	-	3.39	19.69	12.17	243
8	17.99	17.72	8.46	-	5.12	19.69	16.46	552	17.99	16.77	7.20	-	4.13	15.75	16.10	331
10	20.98	18.70	10.24	-	7.17	23.62	18.50	998	20.98	17.72	8.46	-	5.12	19.69	17.60	662
12	24.02	21.65	11.81	-	7.17	23.62	18.50	1424	24.02	18.70	10.24	-	7.17	23.62	18.50	883
14	27.01	25.20	13.39	-	8.23	23.62	19.33	1678	27.01	21.65	11.81	-	7.17	23.62	18.50	1468
16	30.00	25.59	14.96	-	8.23	23.62	19.33	2097	30.00	25.20	13.39	-	8.23	23.62	19.33	1733
18	34.02	31.50	16.57	-	8.23	23.62	19.33	2936	34.02	25.59	14.96	-	8.23	23.62	19.33	2417
20	35.98	33.07	19.29	-	8.23	23.62	19.33	4823	35.98	31.50	16.57	-	10.08	27.56	21.30	4349
24	42.01	35.43	22.05	-	10.08	27.56	21.30	6181	45.00	33.07	19.29	-	10.08	27.56	21.30	4448

#### NOTE

Please consult factory for sizes above 24 in.

# AEV 2XC C-BALL VALVES - CRITICAL SERVICE APPLICATIONS

## DIMENSIONS AND WEIGHTS / ASME CLASS 300 - BW END CONNECTIONS

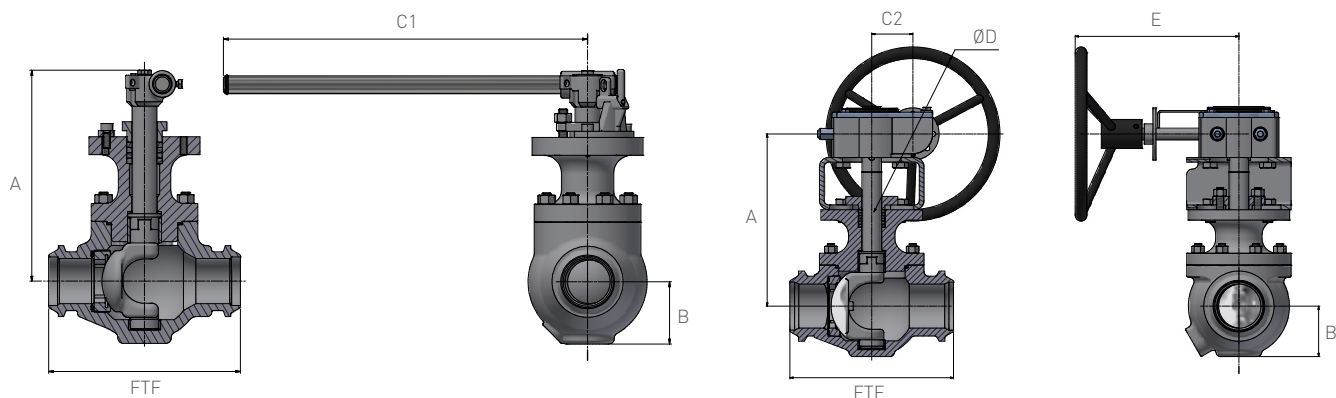

Lever Operated  
 Sizes DN 15 - 40 / NPS 1/2 - 1 1/2

Handwheel Operated  
 Sizes DN 50 - 600 / NPS 2 - 24

### ASME CLASS 300 DIMENSIONS mm

Size in	Full Bore								Reduced Bore							
DN	FTF	A	B	C1	C2	ØD	E	Weight kg	FTF	A	B	C1	C2	ØD	E	Weight kg
15	140	172	36	245	-	-	-	7	-	-	-	-	-	-	-	-
20	152	172	45	330	-	-	-	7	-	-	-	-	-	-	-	-
25	165	172	45	330	-	-	-	8	-	-	-	-	-	-	-	-
40	190	209	68	410	-	-	-	14	-	-	-	-	-	-	-	-
50	216	150	70	-	52	300	252	26	216	125	70	-	52	300	252	25
65	241	200	85	-	86	400	286	45	241	150	70	-	52	300	252	25
80	283	250	87	-	86	400	286	55	283	200	70	-	71	300	252	25
100	305	385	122	-	105	400	409	95	305	250	90	-	86	400	286	58
150	457	430	179	-	105	400	409	160	457	385	130	-	86	500	309	110
200	521	475	215	-	182	500	470	240	521	430	183	-	105	400	409	180
250	559	500	260	-	182	500	470	430	559	475	215	-	182	500	470	290
300	635	550	300	-	209	600	491	600	635	500	260	-	182	500	470	485
350	762	640	340	-	209	600	491	815	762	550	300	-	209	600	491	715
400	838	750	380	-	209	600	491	1200	838	640	340	-	209	600	491	1095
450	914	850	421	-	256	700	531	1500	914	750	380	-	209	600	491	1490
500	991	890	490	-	256	700	531	2100	991	850	421	-	256	700	531	1855
600	1143	975	560	-	424	750	711	3000	1143	890	490	-	256	700	531	2140

### ASME CLASS 300 DIMENSIONS inch

Size in	Full Bore								Reduced Bore							
NPS	FTF	A	B	C1	C2	ØD	E	Weight lbs	FTF	A	B	C1	C2	ØD	E	Weight lbs
1/2	5.51	6.77	1.42	9.65	-	-	-	15	-	-	-	-	-	-	-	-
3/4	5.98	6.77	1.77	12.99	-	-	-	15	-	-	-	-	-	-	-	-
1	6.50	6.77	1.77	12.99	-	-	-	18	-	-	-	-	-	-	-	-
1 1/2	7.48	8.23	2.68	16.14	-	-	-	31	-	-	-	-	-	-	-	-
2	8.50	5.91	2.76	-	2.05	11.81	9.92	57	8.50	4.92	2.76	-	2.05	11.81	9.92	55
2 1/2	9.49	7.87	3.35	-	3.39	15.75	11.26	99	9.49	5.91	2.76	-	2.05	11.81	9.92	55
3	11.14	9.84	3.43	-	3.39	15.75	11.26	121	11.14	7.87	2.76	-	2.80	11.81	9.92	55
4	12.01	15.16	4.80	-	4.13	15.75	16.10	210	12.01	9.84	3.54	-	3.39	15.75	11.26	128
6	17.99	16.93	7.05	-	4.13	15.75	16.10	353	17.99	15.16	5.12	-	3.39	19.69	12.17	243
8	20.51	18.70	8.46	-	7.17	19.69	18.50	530	20.51	16.93	7.20	-	4.13	15.75	16.10	397
10	22.01	19.69	10.24	-	7.17	19.69	18.50	949	22.01	18.70	8.46	-	7.17	19.69	18.50	640
12	25.00	21.65	11.81	-	8.23	23.62	19.33	1325	25.00	19.69	10.24	-	7.17	19.69	18.50	1071
14	30.00	25.20	13.39	-	8.23	23.62	19.33	1799	30.00	21.65	11.81	-	8.23	23.62	19.33	1578
16	32.99	29.53	14.96	-	8.23	23.62	19.33	2649	32.99	25.20	13.39	-	8.23	23.62	19.33	2417
18	35.98	33.46	16.57	-	10.08	27.56	20.91	3311	35.98	29.53	14.96	-	8.23	23.62	19.33	3289
20	39.02	35.04	19.29	-	10.08	27.56	20.91	4636	39.02	33.46	16.57	-	10.08	27.56	20.91	4095
24	45.00	38.39	22.05	-	16.69	29.53	27.99	6623	45.00	35.04	19.29	-	10.08	27.56	20.91	4724

#### NOTE

Please consult factory for sizes above 24 in.

# AEV 2XC C-BALL VALVES - CRITICAL SERVICE APPLICATIONS

## DIMENSIONS AND WEIGHTS / ASME CLASS 300 - FLANGED END CONNECTIONS

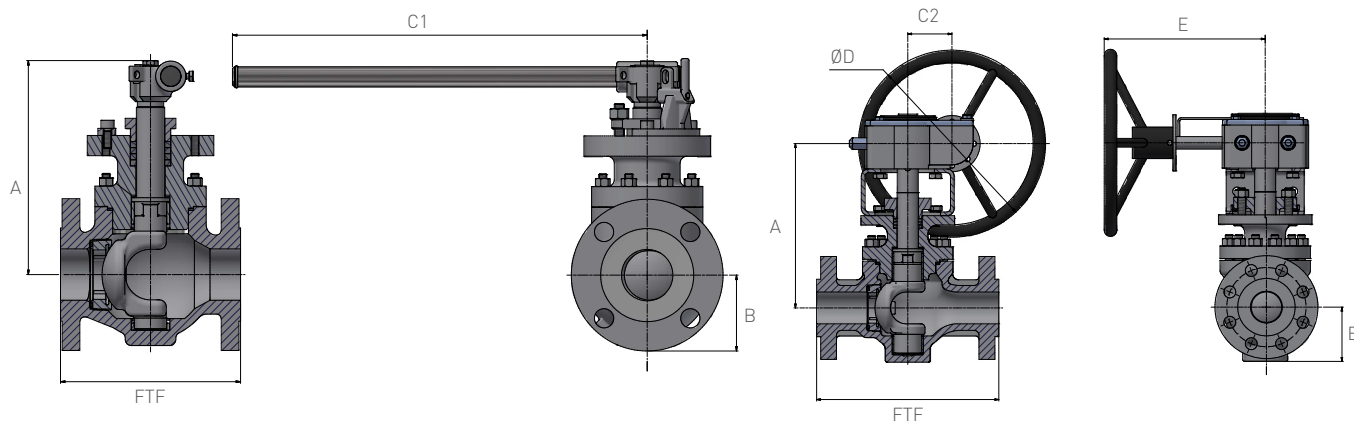

Lever Operated  
 Sizes DN 15 - 40 / NPS 1/2 - 1 1/2

Handwheel Operated  
 Sizes DN 50 - 600 / NPS 2 - 24

### ASME CLASS 300 DIMENSIONS mm

Size in	Full Bore								Reduced Bore							
DN	FTF	A	B	C1	C2	ØD	E	Weight kg	FTF	A	B	C1	C2	ØD	E	Weight kg
15	140	172	48	245	-	-	-	7	-	-	-	-	-	-	-	-
20	152	172	58	330	-	-	-	8	-	-	-	-	-	-	-	-
25	165	172	63	330	-	-	-	10	-	-	-	-	-	-	-	-
40	190	209	78	410	-	-	-	12	-	-	-	-	-	-	-	-
50	216	150	83	-	52	300	252	27	216	125	83	-	52	300	252	25
65	241	200	95	-	86	400	286	45	241	150	95	-	52	300	252	25
80	283	250	105	-	86	400	286	55	283	200	105	-	86	300	252	50
100	305	385	122	-	105	400	409	95	305	250	127	-	86	400	286	68
150	403	430	179	-	105	400	409	185	403	385	160	-	105	500	309	110
200	502	475	215	-	182	500	470	250	502	430	190	-	105	400	409	240
250	568	500	260	-	182	500	470	430	568	475	223	-	182	500	470	350
300	648	550	300	-	209	600	491	650	648	500	260	-	182	500	470	525
350	762	640	340	-	209	600	491	815	762	550	300	-	209	600	491	715
400	838	750	380	-	209	600	491	1200	838	640	340	-	209	600	491	1215
450	914	850	421	-	256	700	531	1500	914	750	380	-	209	600	491	1650
500	991	890	490	-	256	700	531	2100	991	850	421	-	256	700	531	2040
600	1143	975	560	-	424	750	711	3000	1143	890	490	-	256	700	531	2375

### ASME CLASS 300 DIMENSIONS inch

Size in	Full Bore								Reduced Bore							
NPS	FTF	A	B	C1	C2	ØD	E	Weight lbs	FTF	A	B	C1	C2	ØD	E	Weight lbs
1/2	5.51	6.77	1.89	9.65	-	-	-	15	-	-	-	-	-	-	-	-
3/4	5.98	6.77	2.28	12.99	-	-	-	18	-	-	-	-	-	-	-	-
1	6.50	6.77	2.48	12.99	-	-	-	22	-	-	-	-	-	-	-	-
1 1/2	7.48	8.23	3.07	16.14	-	-	-	26	-	-	-	-	-	-	-	-
2	8.50	5.91	3.27	-	2.05	11.81	9.92	60	8.50	4.92	3.27	-	2.05	11.81	9.92	55
2 1/2	9.49	7.87	3.74	-	3.39	15.75	11.26	99	9.49	5.91	3.74	-	2.05	11.81	9.92	55
3	11.14	9.84	4.13	-	3.39	15.75	11.26	121	11.14	7.87	4.13	-	2.80	11.81	9.92	110
4	12.01	15.16	4.80	-	4.13	15.75	16.10	210	12.01	9.84	5.00	-	3.39	15.75	11.26	150
6	15.87	16.93	7.05	-	4.13	15.75	16.10	408	15.87	15.16	6.30	-	3.39	19.69	12.17	243
8	19.76	18.70	8.46	-	7.17	19.69	18.50	552	19.76	16.93	7.48	-	4.13	15.75	16.10	530
10	22.36	19.69	10.24	-	7.17	19.69	18.50	949	22.36	18.70	8.78	-	7.17	19.69	18.50	773
12	25.51	21.65	11.81	-	8.23	23.62	19.33	1435	25.51	19.69	10.24	-	7.17	19.69	18.50	1159
14	30.00	25.20	13.39	-	8.23	23.62	19.33	1799	30.00	21.65	11.81	-	8.23	23.62	19.33	1578
16	32.99	29.53	14.96	-	8.23	23.62	19.33	2649	32.99	25.20	13.39	-	8.23	23.62	19.33	2682
18	35.98	33.46	16.57	-	10.08	27.56	20.91	3311	35.98	29.53	14.96	-	8.23	23.62	19.33	3642
20	39.02	35.04	19.29	-	10.08	27.56	20.91	4636	39.02	33.46	16.57	-	10.08	27.56	20.91	4503
24	45.00	38.39	22.05	-	16.69	29.53	27.99	6623	45.00	35.04	19.29	-	10.08	27.56	20.91	5243

#### NOTE

Please consult factory for sizes above 24 in



# AEV 2XC C-BALL VALVES - CRITICAL SERVICE APPLICATIONS

## DIMENSIONS AND WEIGHTS / ASME CLASS 600 - BW END CONNECTIONS

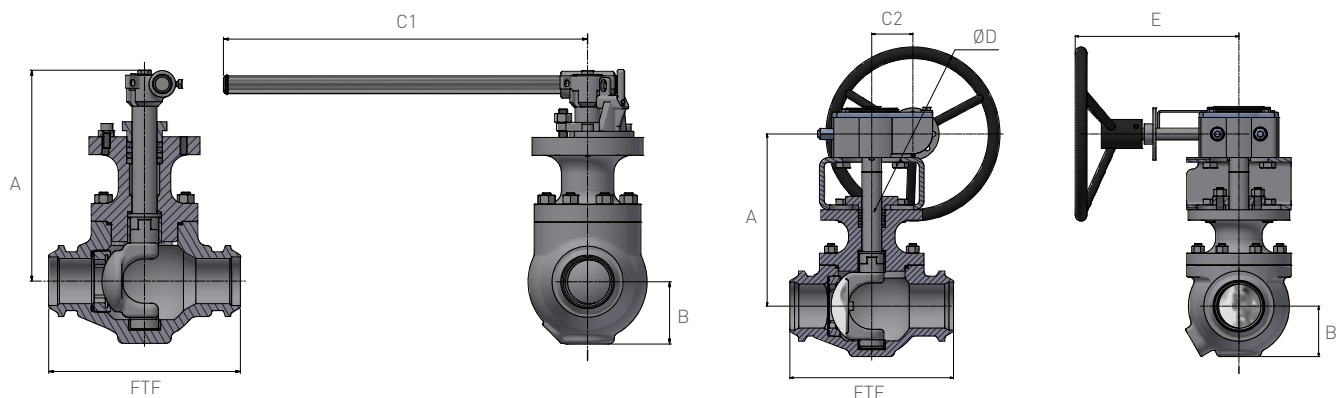

Lever Operated  
 Sizes DN 15 - 40 / NPS 1/2 - 1 1/2

Handwheel Operated  
 Sizes DN 50 - 600 / NPS 2 - 24

### ASME CLASS 600 DIMENSIONS mm

Size in	Full Bore								Reduced Bore							
DN	FTF	A	B	C1	C2	ØD	E	Weight kg	FTF	A	B	C1	C2	ØD	E	Weight kg
15	165	172	37	245	-	-	-	7	-	-	-	-	-	-	-	-
20	190	172	45	330	-	-	-	8	-	-	-	-	-	-	-	-
25	216	172	45	330	-	-	-	8	-	-	-	-	-	-	-	-
40	241	209	68	410	-	-	-	15	-	-	-	-	-	-	-	-
50	292	264	87	-	71	300	258	34	292	250	87	-	71	300	284	45
65	330	275	94	-	86	400	286	45	330	264	87	-	71	300	284	45
80	356	305	116	-	86	500	306	60	356	274	87	-	86	300	284	45
100	432	410	136	-	105	400	409	100	432	305	116	-	86	500	309	95
150	559	525	185	-	130	500	418	200	559	410	137	-	105	400	409	160
200	660	575	240	-	182	600	450	400	660	525	187	-	130	500	418	300
250	787	610	288	-	182	600	470	590	787	575	242	-	182	600	470	470
300	838	725	325	-	205	600	496	950	838	610	288	-	182	600	470	760
350	889	825	365	-	205	600	496	1190	889	725	325	-	205	600	496	950
400	991	870	405	-	256	700	531	1520	991	825	365	-	205	600	496	1215
450	1092	950	460	-	339	750	800	2090	1092	870	405	-	256	700	531	1670
500	1194	995	510	-	339	750	800	3090	1194	950	460	-	339	750	800	2470
600	1397	1120	620	-	402	750	832	4085	1397	995	510	-	339	750	800	3270

### ASME CLASS 600 DIMENSIONS inch

Size in	Full Bore								Reduced Bore							
NPS	FTF	A	B	C1	C2	ØD	E	Weight lbs	FTF	A	B	C1	C2	ØD	E	Weight lbs
1/2	6.50	6.77	1.46	9.65	-	-	-	15	-	-	-	-	-	-	-	-
3/4	7.48	6.77	1.77	12.99	-	-	-	18	-	-	-	-	-	-	-	-
1	8.50	6.77	1.77	12.99	-	-	-	18	-	-	-	-	-	-	-	-
1 1/2	9.49	8.23	2.68	16.14	-	-	-	33	-	-	-	-	-	-	-	-
2	11.50	10.39	3.43	-	2.80	11.81	10.16	75	11.50	9.84	3.43	-	2.80	11.81	11.18	99
2 1/2	12.99	10.83	3.70	-	3.39	15.75	11.26	99	12.99	10.39	3.43	-	2.80	11.81	11.18	99
3	14.02	12.01	4.57	-	3.39	19.69	12.05	132	14.02	10.79	3.43	-	3.39	11.81	11.18	99
4	17.01	16.14	5.35	-	4.13	15.75	16.10	221	17.01	12.01	4.57	-	3.39	19.69	12.17	210
6	22.01	20.67	7.28	-	5.12	19.69	16.46	442	22.01	16.14	5.39	-	4.13	15.75	16.10	353
8	25.98	22.64	9.45	-	7.17	23.62	17.72	883	25.98	20.67	7.36	-	5.12	19.69	16.46	662
10	30.98	24.02	11.34	-	7.17	23.62	18.50	1302	30.98	22.64	9.53	-	7.17	23.62	18.50	1038
12	32.99	28.54	12.80	-	8.07	23.62	19.53	2097	32.99	24.02	11.34	-	7.17	23.62	18.50	1678
14	35.00	32.48	14.37	-	8.07	23.62	19.53	2627	35.00	28.54	12.80	-	8.07	23.62	19.53	2097
16	39.02	34.25	15.94	-	10.08	27.56	20.91	3355	39.02	32.48	14.37	-	8.07	23.62	19.53	2682
18	42.99	37.40	18.11	-	13.35	29.53	31.50	4614	42.99	34.25	15.94	-	10.08	27.56	20.91	3687
20	47.01	39.17	20.08	-	13.35	29.53	31.50	6821	47.01	37.40	18.11	-	13.35	29.53	31.50	5453
24	55.00	44.09	24.41	-	15.83	29.53	32.76	9018	55.00	39.17	20.08	-	13.35	29.53	31.50	7219

#### NOTE

Please consult factory for sizes above 24 in.

# AEV 2XC C-BALL VALVES - CRITICAL SERVICE APPLICATIONS

## DIMENSIONS AND WEIGHTS / ASME CLASS 600 - FLANGED END CONNECTIONS

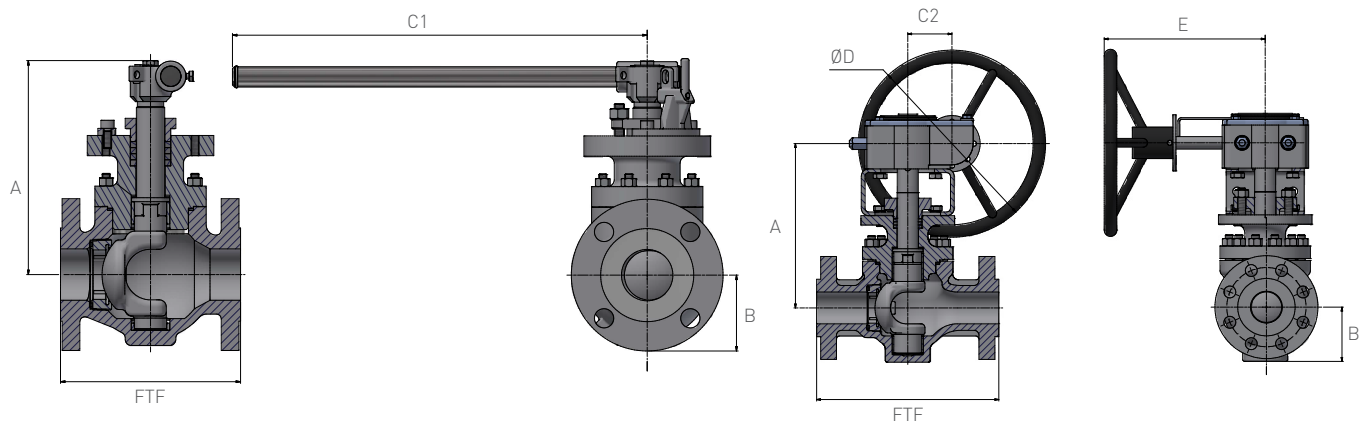

Lever Operated  
 Sizes DN 15 - 40 / NPS 1/2 - 1 1/2

Handwheel Operated  
 Sizes DN 50 - 600 / NPS 2 - 24

### ASME CLASS 600 DIMENSIONS mm

Size in	Full Bore								Reduced Bore							
DN	FTF	A	B	C1	C2	ØD	E	Weight kg	FTF	A	B	C1	C2	ØD	E	Weight kg
15	165	172	48	245	-	-	-	8	-	-	-	-	-	-	-	-
20	190	172	58	330	-	-	-	10	-	-	-	-	-	-	-	-
25	216	172	63	330	-	-	-	10	-	-	-	-	-	-	-	-
40	241	209	78	410	-	-	-	20	-	-	-	-	-	-	-	-
50	292	264	87	-	71	300	258	34	292	250	87	-	71	300	284	29
65	330	275	94	-	86	400	286	45	330	264	90	-	71	300	284	45
80	356	305	116	-	86	500	306	70	356	275	105	-	86	300	284	51
100	432	410	136	-	105	400	409	139	432	305	138	-	86	500	309	120
150	559	525	185	-	130	500	418	250	559	410	173	-	105	400	409	190
200	660	575	240	-	182	600	450	525	660	525	210	-	130	500	418	360
250	787	610	288	-	182	600	470	650	787	575	255	-	182	600	470	570
300	838	725	325	-	205	600	496	950	838	610	288	-	182	600	470	875
350	889	825	365	-	205	600	496	1250	889	725	325	-	205	600	496	1100
400	991	870	405	-	256	700	531	1520	991	825	365	-	205	600	496	1500
450	1092	950	460	-	339	750	800	2090	1092	870	405	-	256	700	531	1900
500	1194	995	510	-	339	750	800	3090	1194	950	460	-	339	750	800	1810
600	1397	1120	620	-	402	750	832	4085	1397	995	510	-	339	750	800	3610

### ASME CLASS 600 DIMENSIONS inch

Size in	Full Bore								Reduced Bore							
NPS	FTF	A	B	C1	C2	ØD	E	Weight lbs	FTF	A	B	C1	C2	ØD	E	Weight lbs
1/2	6.50	6.77	1.89	9.65	-	-	-	18	-	-	-	-	-	-	-	-
3/4	7.48	6.77	2.28	12.99	-	-	-	22	-	-	-	-	-	-	-	-
1	8.50	6.77	2.48	12.99	-	-	-	22	-	-	-	-	-	-	-	-
1 1/2	9.49	8.23	3.07	16.14	-	-	-	44	-	-	-	-	-	-	-	-
2	11.50	10.39	3.43	-	2.80	11.81	10.16	75	11.50	9.84	3.43	-	2.80	11.81	11.18	64
2 1/2	12.99	10.83	3.70	-	3.39	15.75	11.26	99	12.99	10.39	3.54	-	2.80	11.81	11.18	99
3	14.02	12.01	4.57	-	3.39	19.69	12.05	155	14.02	10.83	4.13	-	3.39	11.81	11.18	113
4	17.01	16.14	5.35	-	4.13	15.75	16.10	307	17.01	12.01	5.43	-	3.39	19.69	12.17	265
6	22.01	20.67	7.28	-	5.12	19.69	16.46	552	22.01	16.14	6.81	-	4.13	15.75	16.10	419
8	25.98	22.64	9.45	-	7.17	23.62	17.72	1159	25.98	20.67	8.27	-	5.12	19.69	16.46	795
10	30.98	24.02	11.34	-	7.17	23.62	18.50	1435	30.98	22.64	10.04	-	7.17	23.62	18.50	1258
12	32.99	28.54	12.80	-	8.07	23.62	19.53	2097	32.99	24.02	11.34	-	7.17	23.62	18.50	1932
14	35.00	32.48	14.37	-	8.07	23.62	19.53	2759	35.00	28.54	12.80	-	8.07	23.62	19.53	2428
16	39.02	34.25	15.94	-	10.08	27.56	20.91	3355	39.02	32.48	14.37	-	8.07	23.62	19.53	3311
18	42.99	37.40	18.11	-	13.35	29.53	31.50	4614	42.99	34.25	15.94	-	10.08	27.56	20.91	4194
20	47.01	39.17	20.08	-	13.35	29.53	31.50	6821	47.01	37.40	18.11	-	13.35	29.53	31.50	3996
24	55.00	44.09	24.41	-	15.83	29.53	32.76	9018	55.00	39.17	20.08	-	13.35	29.53	31.50	7969

#### NOTE

Please consult factory for sizes above 24 in.

# AEV 2XC C-BALL VALVES - CRITICAL SERVICE APPLICATIONS

## DIMENSIONS AND WEIGHTS / ASME CLASS 900 - BW END CONNECTIONS

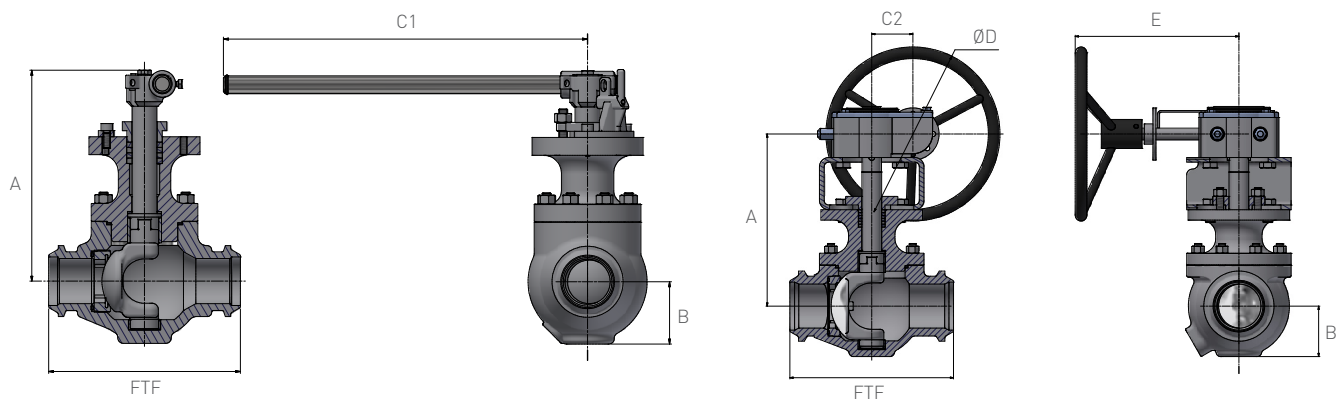

Lever Operated  
 Sizes DN 15 - 25 / NPS 1/2 - 1

Handwheel Operated  
 Sizes DN 40 - 600 / NPS 1 1/2 - 24

### ASME CLASS 900 DIMENSIONS mm

Size in	Full Bore								Reduced Bore							
DN	FTF	A	B	C1	C2	ØD	E	Weight kg	FTF	A	B	C1	C2	ØD	E	Weight kg
15	216	172	45	330	-	-	-	11	-	-	-	-	-	-	-	-
20	229	172	48	330	-	-	-	11	-	-	-	-	-	-	-	-
25	254	172	48	410	-	-	-	11	-	-	-	-	-	-	-	-
40	305	250	82	-	52	300	232	30	305	200	82	-	52	300	232	35
50	368	265	95	-	86	400	286	75	368	250	95	-	86	400	286	35
65	419	285	95	-	86	500	306	80	419	265	95	-	86	500	306	50
80	381	385	116	-	86	500	306	85	381	285	116	-	86	500	306	60
100	457	405	140	-	130	400	398	140	457	385	140	-	130	400	398	120
150	610	540	190	-	182	500	470	240	610	405	190	-	182	500	470	150
200	737	690	250	-	182	600	470	600	737	540	250	-	182	600	470	380
250	838	730	300	-	209	600	491	900	838	690	300	-	209	600	491	600
300	965	855	320	-	306	600	491	1000	965	730	320	-	306	600	491	855
350	1029	920	375	-	339	700	626	1285	1029	855	375	-	339	700	626	1025
400	1130	1015	425	-	339	700	800	2115	1130	920	425	-	339	700	800	1650
450	1219	1125	475	-	402	750	800	2850	1219	1025	475	-	402	750	800	2375
500	1321	1170	525	-	402	750	800	4180	1321	1125	525	-	402	750	800	3680
600	1549	1310	575	-	425	750	832	4895	1549	1170	575	-	425	750	832	3660

### ASME CLASS 900 DIMENSIONS inch

Size in	Full Bore								Reduced Bore							
NPS	FTF	A	B	C1	C2	ØD	E	Weight lbs	FTF	A	B	C1	C2	ØD	E	Weight lbs
1/2	8.50	6.77	1.77	12.99	-	-	-	24	-	-	-	-	-	-	-	-
3/4	9.02	6.77	1.89	12.99	-	-	-	24	-	-	-	-	-	-	-	-
1	10.00	6.77	1.89	16.14	-	-	-	24	-	-	-	-	-	-	-	-
1 1/2	12.01	9.84	3.23	-	2.05	11.81	9.13	66	12.01	7.87	3.23	-	2.05	11.81	9.13	77
2	14.49	10.43	3.74	-	3.39	15.75	11.26	166	14.49	9.84	3.74	-	3.39	15.75	11.26	77
2 1/2	16.50	11.22	3.74	-	3.39	19.69	12.05	177	16.50	10.43	3.74	-	3.39	19.69	12.05	110
3	15.00	15.16	4.57	-	3.39	19.69	12.05	188	15.00	11.22	4.57	-	3.39	19.69	12.05	132
4	17.99	15.94	5.51	-	5.12	15.75	15.67	309	17.99	15.16	5.51	-	5.12	15.75	15.67	265
6	24.02	21.26	7.48	-	7.17	19.69	18.50	530	24.02	15.94	7.48	-	7.17	19.69	18.50	331
8	29.02	27.17	9.84	-	7.17	23.62	18.50	1325	29.02	21.26	9.84	-	7.17	23.62	18.50	839
10	32.99	28.74	11.81	-	8.23	23.62	19.33	1987	32.99	27.17	11.81	-	8.23	23.62	19.33	1325
12	37.99	33.66	12.60	-	12.05	23.62	19.33	2208	37.99	28.74	12.60	-	12.05	23.62	19.33	1887
14	40.51	36.22	14.76	-	13.35	27.56	24.65	2837	40.51	33.66	14.76	-	13.35	27.56	24.65	2263
16	44.49	39.96	16.73	-	13.35	27.56	31.50	4669	44.49	36.22	16.73	-	13.35	27.56	31.50	3642
18	47.99	44.29	18.70	-	15.83	29.53	31.50	6291	47.99	40.35	18.70	-	15.83	29.53	31.50	5243
20	52.01	46.06	20.67	-	15.83	29.53	31.50	9227	52.01	44.29	20.67	-	15.83	29.53	31.50	8124
24	60.98	51.57	22.64	-	16.73	29.53	32.76	10806	60.98	46.06	22.64	-	16.73	29.53	32.76	8079

#### NOTE

Please consult factory for sizes above 24 in.

# AEV 2XC C-BALL VALVES - CRITICAL SERVICE APPLICATIONS

## DIMENSIONS AND WEIGHTS / ASME CLASS 900 - FLANGED END CONNECTIONS

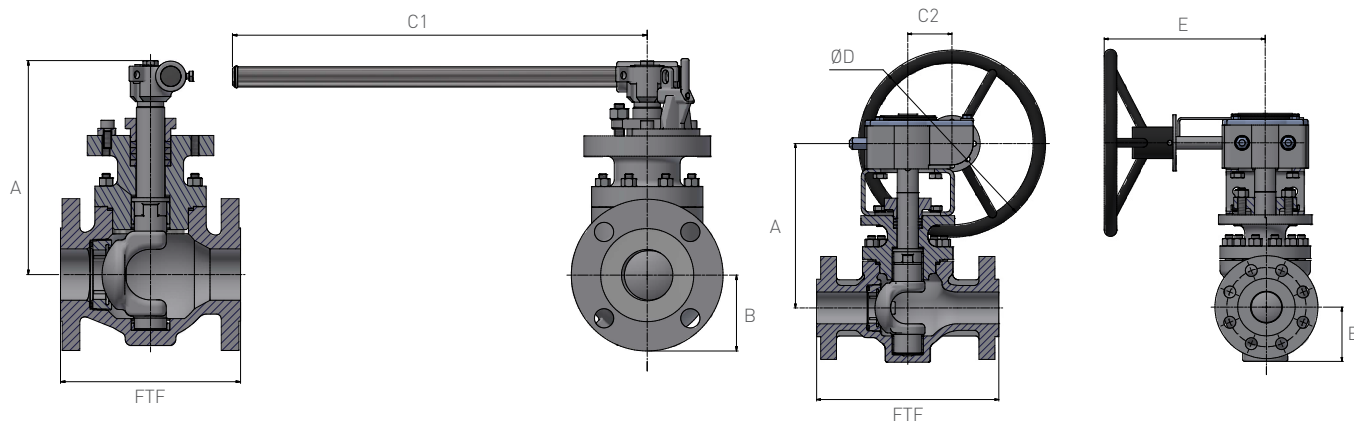

Lever Operated  
 Sizes DN 15 - 25 / NPS 1/2 - 1

Handwheel Operated  
 Sizes DN 40 - 600 / NPS 1 1/2 - 24

### ASME CLASS 900 DIMENSIONS mm

Size in	Full Bore								Reduced Bore								
	DN	FTF	A	B	C1	C2	ØD	E	Weight kg	FTF	A	B	C1	C2	ØD	E	Weight kg
15	216	172	60	330	-	-	-	-	12	-	-	-	-	-	-	-	-
20	229	172	65	330	-	-	-	-	15	-	-	-	-	-	-	-	-
25	254	172	75	410	-	-	-	-	15	-	-	-	-	-	-	-	-
40	305	250	90	-	52	300	232	30	305	200	90	-	52	300	232	35	305
50	368	265	108	-	86	400	286	75	368	250	107	-	86	400	286	50	368
65	419	285	123	-	86	500	306	80	419	265	123	-	86	500	306	65	419
80	381	385	120	-	86	500	306	120	381	285	120	-	86	500	306	75	381
100	457	405	145	-	130	400	398	180	457	385	145	-	130	400	398	145	457
150	610	540	190	-	182	500	470	300	610	405	190	-	182	500	470	200	610
200	737	690	250	-	182	600	470	685	737	540	250	-	182	600	470	475	737
250	838	730	300	-	209	600	491	1000	838	690	300	-	209	600	491	840	838
300	965	855	320	-	306	600	491	1200	965	730	320	-	306	600	491	1035	965
350	1029	920	375	-	339	700	626	1500	1029	855	375	-	339	700	626	1315	1029
400	1130	1015	425	-	339	700	800	2400	1130	920	425	-	339	700	800	1890	1130
450	1219	1125	475	-	402	750	800	3100	1219	1025	475	-	402	750	800	2695	1219
500	1321	1170	525	-	402	750	800	4700	1321	1125	525	-	402	750	800	3600	1321
600	1549	1310	575	-	425	750	832	6000	1549	1170	575	-	425	750	832	4465	1549

### ASME CLASS 900 DIMENSIONS inch

Size in	Full Bore								Reduced Bore								
	NPS	FTF	A	B	C1	C2	ØD	E	Weight lbs	FTF	A	B	C1	C2	ØD	E	Weight lbs
1/2	8.50	6.77	2.36	12.99	-	-	-	-	26	-	-	-	-	-	-	-	-
3/4	9.02	6.77	2.56	12.99	-	-	-	-	33	-	-	-	-	-	-	-	-
1	10.0	6.77	2.95	16.14	-	-	-	-	33	-	-	-	-	-	-	-	-
1 1/2	12.01	9.84	3.54	-	2.05	11.81	9.13	66	12.01	7.87	3.54	-	2.05	11.81	9.13	77	12.01
2	14.49	10.43	4.25	-	3.39	15.75	11.26	166	14.49	9.84	4.21	-	3.39	15.75	11.26	110	14.49
2 1/2	16.50	11.22	4.84	-	3.39	19.69	12.05	177	16.50	10.43	4.84	-	3.39	19.69	12.05	143	16.50
3	15.00	15.16	4.72	-	3.39	19.69	12.05	265	15.00	11.22	4.72	-	3.39	19.69	12.05	166	15.00
4	17.99	15.94	5.71	-	5.12	15.75	15.67	397	17.99	15.16	5.71	-	5.12	15.75	15.67	320	17.99
6	24.02	21.26	7.48	-	7.17	19.69	18.50	662	24.02	15.94	7.48	-	7.17	19.69	18.50	442	24.02
8	29.02	27.17	9.84	-	7.17	23.62	18.50	1512	29.02	21.26	9.84	-	7.17	23.62	18.50	1049	29.02
10	32.99	28.74	11.81	-	8.23	23.62	19.33	2208	32.99	27.17	11.81	-	8.23	23.62	19.33	1854	32.99
12	37.99	33.66	12.6	-	12.05	23.62	19.33	2649	37.99	28.74	12.60	-	12.05	23.62	19.33	2285	37.99
14	40.51	36.22	14.76	-	13.35	27.56	24.65	3311	40.51	33.66	14.76	-	13.35	27.56	24.65	2903	40.51
16	44.49	39.96	16.73	-	13.35	27.56	31.50	5298	44.49	36.22	16.73	-	13.35	27.56	31.50	4172	44.49
18	47.99	44.29	18.70	-	15.83	29.53	31.50	6843	47.99	40.35	18.70	-	15.83	29.53	31.50	5949	47.99
20	52.01	46.06	20.67	-	15.83	29.53	31.50	10375	52.01	44.29	20.67	-	15.83	29.53	31.50	7947	52.01
24	60.98	51.57	22.64	-	16.73	29.53	32.76	13245	60.98	46.06	22.64	-	16.73	29.53	32.76	9857	60.98

#### NOTE

Please consult factory for sizes above 24 in.

# AEV 2XC C-BALL VALVES - CRITICAL SERVICE APPLICATIONS

## DIMENSIONS AND WEIGHTS / ASME CLASS 1500 - BW END CONNECTIONS

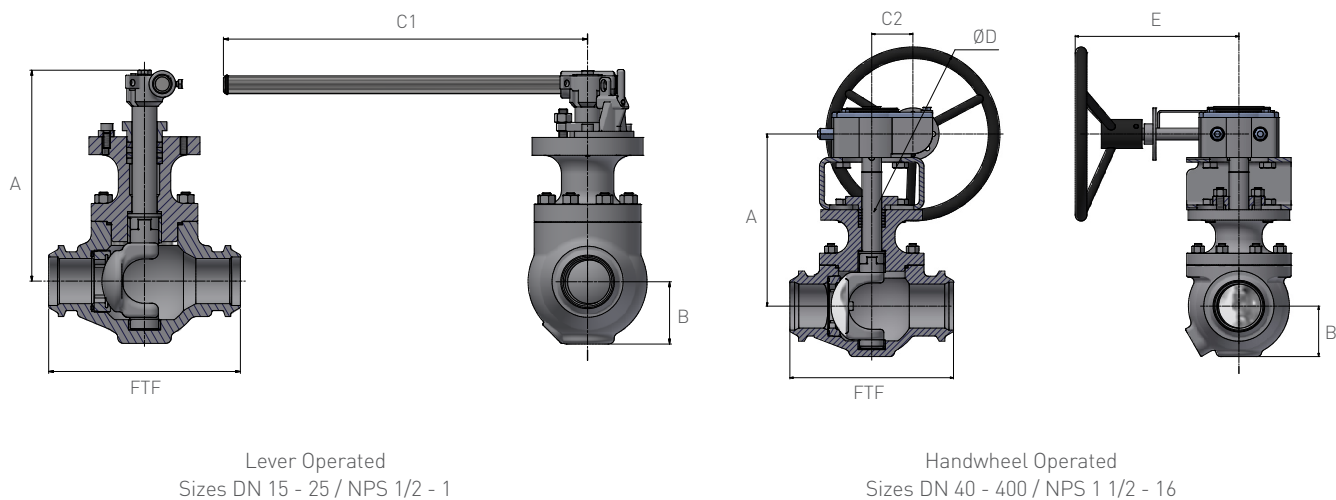

### ASME CLASS 1500 DIMENSIONS mm

Size in	Full Bore								Reduced Bore								
	DN	FTF	A	B	C1	C2	ØD	E	Weight kg	FTF	A	B	C1	C2	ØD	E	Weight kg
15	216	172	45	330	-	-	-	-	11	-	-	-	-	-	-	-	-
20	229	172	48	330	-	-	-	-	11	-	-	-	-	-	-	-	-
25	254	172	48	410	-	-	-	-	11	-	-	-	-	-	-	-	-
40	305	250	82	-	52	300	232	30	305	200	82	-	52	300	232	30	30
50	368	265	95	-	86	400	286	75	368	250	95	-	86	400	286	75	75
65	419	400	105	-	130	400	397	95	419	265	105	-	130	400	397	95	95
80	470	480	120	-	130	400	397	115	470	400	120	-	130	400	397	115	115
100	546	610	155	-	211	500	447	205	546	480	155	-	211	500	447	205	205
150	705	750	200	-	367	600	571	500	705	610	200	-	367	600	571	500	500
200	832	805	280	-	384	700	571	950	832	750	280	-	384	700	571	950	950
250	991	845	325	-	384	700	571	1725	991	805	325	-	384	700	571	1725	1725
300	1130	860	350	-	406	750	626	1995	1130	845	350	-	406	750	626	1995	1995
350	1257	975	400	-	406	750	626	2510	1257	860	400	-	406	750	626	2510	2510
400	1384	1050	450	-	406	750	626	3500	1384	975	450	-	406	750	626	3500	3500

### ASME CLASS 1500 DIMENSIONS inch

Size in	Full Bore								Reduced Bore								
	NPS	FTF	A	B	C1	C2	ØD	E	Weight lbs	FTF	A	B	C1	C2	ØD	E	Weight lbs
1/2	8.50	6.77	1.77	12.99	-	-	-	-	24	-	-	-	-	-	-	-	-
3/4	9.02	6.77	1.89	12.99	-	-	-	-	24	-	-	-	-	-	-	-	-
1	10.00	6.77	1.89	16.14	-	-	-	-	24	-	-	-	-	-	-	-	-
1 1/2	12.01	9.84	3.23	-	2.05	11.81	9.13	66	12.01	7.87	3.23	-	2.05	11.81	9.13	66	66
2	14.49	10.43	3.74	-	3.39	15.75	11.26	166	14.49	9.84	3.74	-	3.39	15.75	11.26	166	166
2 1/2	16.50	15.75	4.13	-	5.12	15.75	15.63	210	16.50	10.43	4.13	-	5.12	15.75	15.63	210	210
3	18.50	18.90	4.72	-	5.12	15.75	15.63	254	18.50	15.75	4.72	-	5.12	15.75	15.63	254	254
4	21.50	24.02	6.10	-	8.31	19.69	17.60	453	21.50	18.90	6.10	-	8.31	19.69	17.60	453	453
6	27.76	29.53	7.87	-	14.45	23.62	22.48	1104	27.76	24.02	7.87	-	14.45	23.62	22.48	1104	1104
8	32.76	31.69	11.02	-	15.12	27.56	22.48	2097	32.76	29.53	11.02	-	15.12	27.56	22.48	2097	2097
10	39.02	33.27	12.80	-	15.12	27.56	22.48	3808	39.02	31.69	12.80	-	15.12	27.56	22.48	3808	3808
12	44.49	33.86	13.78	-	15.98	29.53	24.65	4404	44.49	33.27	13.78	-	15.98	29.53	24.65	4404	4404
14	49.49	38.39	15.75	-	15.98	29.53	24.65	5541	49.49	33.86	15.75	-	15.98	29.53	24.65	5541	5541
16	54.49	41.34	17.72	-	15.98	29.53	24.65	7726	54.49	38.39	17.72	-	15.98	29.53	24.65	7726	7726

#### NOTE

Please consult factory for sizes above 16 in.

# AEV 2XC C-BALL VALVES - CRITICAL SERVICE APPLICATIONS

## DIMENSIONS AND WEIGHTS / ASME CLASS 1500 - FLANGED END CONNECTIONS

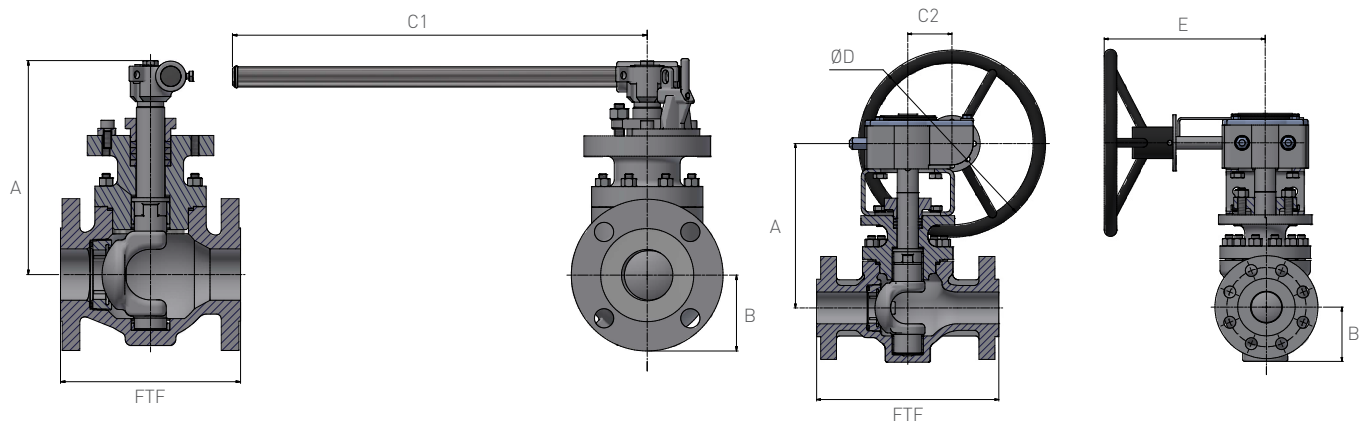

Lever Operated  
 Sizes DN 15 - 25 / NPS 1/2 - 1

Handwheel Operated  
 Sizes DN 40 - 400 / NPS 1 1/2 - 16

### ASME CLASS 1500 DIMENSIONS mm

Size in	Full Bore								Reduced Bore							
DN	FTF	A	B	C1	C2	ØD	E	Weight kg	FTF	A	B	C1	C2	ØD	E	Weight kg
15	216	172	60	330	-	-	-	12	-	-	-	-	-	-	-	-
20	229	172	65	330	-	-	-	15	-	-	-	-	-	-	-	-
25	254	172	75	410	-	-	-	15	-	-	-	-	-	-	-	-
40	305	250	90	-	52	300	232	30	305	200	90	-	52	300	232	35
50	368	265	108	-	86	400	286	75	368	250	107	-	86	400	286	50
65	419	400	123	-	130	400	397	80	419	265	123	-	130	400	397	65
80	470	480	133	-	130	400	397	120	470	400	133	-	130	400	397	95
100	546	610	155	-	211	500	447	245	546	480	155	-	211	500	447	180
150	705	750	200	-	367	600	571	595	705	610	200	-	367	600	571	370
200	832	805	280	-	384	700	571	1140	832	750	280	-	384	700	571	785
250	991	845	325	-	384	700	571	2065	991	805	325	-	384	700	571	1350
300	1130	860	350	-	406	750	626	2375	1130	845	350	-	406	750	626	1810
350	1257	975	400	-	406	750	626	2995	1257	860	400	-	406	750	626	2400
400	1384	1050	450	-	406	750	626	4940	1384	975	450	-	406	750	626	4065

### ASME CLASS 1500 DIMENSIONS inch

Size in	Full Bore								Reduced Bore							
NPS	FTF	A	B	C1	C2	ØD	E	Weight lbs	FTF	A	B	C1	C2	ØD	E	Weight lbs
1/2	8.50	6.77	2.36	12.99	-	-	-	26	-	-	-	-	-	-	-	-
3/4	9.02	6.77	2.56	12.99	-	-	-	33	-	-	-	-	-	-	-	-
1	10.00	6.77	2.95	16.14	-	-	-	33	-	-	-	-	-	-	-	-
1 1/2	12.01	9.84	3.54	-	2.05	11.81	9.13	66	12.01	7.87	3.54	-	2.05	11.81	9.13	77
2	14.49	10.43	4.25	-	3.39	15.75	11.26	166	14.49	9.84	4.21	-	3.39	15.75	11.26	110
2 1/2	16.50	15.75	4.84	-	5.12	15.75	15.63	177	16.50	10.43	4.84	-	5.12	15.75	15.63	143
3	18.50	18.90	5.24	-	5.12	15.75	15.63	265	18.50	15.75	5.24	-	5.12	15.75	15.63	210
4	21.50	24.02	6.10	-	8.31	19.69	17.60	541	21.50	18.90	6.10	-	8.31	19.69	17.60	397
6	27.76	29.53	7.87	-	14.45	23.62	22.48	1313	27.76	24.02	7.87	-	14.45	23.62	22.48	817
8	32.76	31.69	11.02	-	15.12	27.56	22.48	2517	32.76	29.53	11.02	-	15.12	27.56	22.48	1733
10	39.02	33.27	12.80	-	15.12	27.56	22.48	4558	39.02	31.69	12.80	-	15.12	27.56	22.48	2980
12	44.49	33.86	13.78	-	15.98	29.53	24.65	5243	44.49	33.27	13.78	-	15.98	29.53	24.65	3996
14	49.49	38.39	15.75	-	15.98	29.53	24.65	6611	49.49	33.86	15.75	-	15.98	29.53	24.65	5298
16	54.49	41.34	17.72	-	15.98	29.53	24.65	10905	54.49	38.39	17.72	-	15.98	29.53	24.65	8974

#### NOTE

Please consult factory for sizes above 16 in.

# AEV<sup>2</sup>XC C-BALL VALVES - CRITICAL SERVICE APPLICATIONS

## CERTIFICATION

### CERTIFICATION TABLE

Quality Management System	ISO 9001:2015	
Regional Product Certification	PED TSG CRN TRCU	
Environmental Management System	ISO 14001:2004	
Health and Safety Management System	OHSAS 18001:2007	
Product	Fire Safety	API 607 / ISO 10497
	Fugitive Emission	ISO 15848-1
	Product Safety	SIL 3
Applicable Product Standards	Design Standards:	ASME B16.34, API 6D and API 608
	Face-to-Face:	ASME B16.10
	Flange Standards:	ASME B16.5 / ASME B16.47; EN 1092-1
	Buttweld Ends:	B 16.25 / EN 12224
Testing Standard Compliance		API 598* ASME B 16.34 ISO 5208 EN 12266-1 ISO 15848-2

### NOTES

\* Isolation and shutoff applications

Sectional drawings and dimensional tables on this datasheet refer to valves with gears. However, note that AEV<sup>TM</sup> valves are suitable for operation with all kinds of quarter-turn actuators (pneumatic, hydraulic, electric, etc.).

FCDS-20190-EN © 2024 Emerson Electric Co. All rights reserved 11/24. AEV is a mark owned by one of the companies of Emerson Electric Co. The Emerson logo is a trademark and service mark of Emerson Electric Co. All other marks are the property of their respective owners.

The contents of this publication are presented for informational purposes only, and while every effort has been made to ensure their accuracy, they are not to be construed as warranties or guarantees, express or implied, regarding the products or services described herein or their use or applicability. All sales are governed by our terms and conditions, which are available upon request. We reserve the right to modify or improve the designs or specifications of such products at any time without notice.

Emerson Electric Co. does not assume responsibility for the selection, use or maintenance of any product. Responsibility for proper selection, use and maintenance of any Emerson Electric Co. product remains solely with the purchaser.

Emerson.com