

February 2025

Type 92B Pressure Reducing Valve

- Extended Diaphragm Service Life
- Two-Path Control
- Elevated Actuator
- Resilient Seats
- Bellows Stem Guide
- Double Post Stem Guide

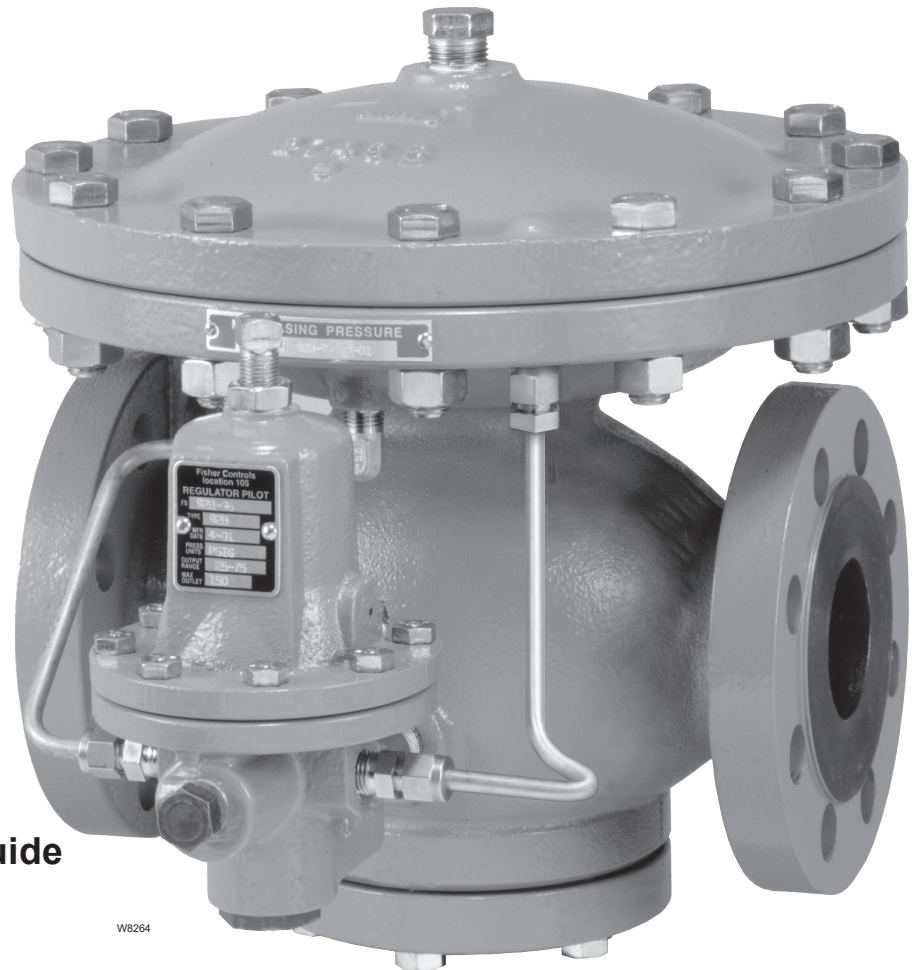

- Standard ANSI Face-to-Face

Figure 1. Type 92B Pressure Reducing Valve

Type 92B

Introduction

The Type 92B Pressure Reducing Valve is the standard steam valve for industry. The Type 92B is designed to provide decades of continuous service. It can withstand dirty operating environments while providing accurate and stable pressure control. The Type 92B is applied as a main Pressure Reducing Valve in industrial process heating applications such as heat exchangers, evaporators, digesters and reactors. Commercial applications include Pressure Reducing Valves for meter runs found in district energy systems, hot water heat exchangers, absorption chillers and boiler deaerator tanks.

The Type 92B is rated for inlet pressure up to 300 psig / 20.7 bar and inlet temperatures to 600°F / 316°C. Maximum controlled outlet pressure is 250 psig / 17.2 bar. A large actuator and heavy main spring ensures high accuracy and stability over its entire steam flow range.

A safety override pilot is available for the Type 92B pressure reducing valve. The Type 92B pilot is used in a series installation with the Type 6492HM safety override pilot installed on the upstream valve. The Type 6492HM safety override pilot senses pressure downstream of the second valve and prevents pressure from rising above safe operating pressure in the event the downstream valve fails. This system is approved by ASME B31.1-1989, 122.14.2.A and can replace an ASME safety valve when vent piping is not practical and upstream steam pressure does not exceed 400 psig / 27.6 bar. Local codes and standards may require approval by an appropriate authority prior to installation.

Features

- **Extended Diaphragm Service Life**—Two-ply construction and dual flex points increases cycle life compared to conventional designs. Stainless steel material ensures satisfactory operation at high steam temperatures.
- **Resilient Seats**—Valve seats are individually lapped for tight shutoff. Beveled seats ensure easy in-line lapping. Plug and valve seats are constructed of hardened stainless steel which reduces wire drawing in wet steam applications.
- **Standard ANSI Face-to-Face**—NPT, CL125 FF, CL150 RF, CL250 RF and CL300 RF end connections are ANSI standard face-to-face dimensions. The Type 92B main valve is also available with PN 16/25/40 RF end connections.
- **Bellows Stem Guide**—Pilot bellows reduces sticking from scale build-up due to boiler carryover.
- **Elevated Actuator**—Plugging from scale and rust is reduced as condensate will not pool in critical areas.
- **Two-Path Control**—Downstream pressure registers under main valve and pilot diaphragms improving response time.
- **Double Post Stem Guide**—Top and bottom seat guides with Inconel® bushings eliminate lateral plug instability and premature stem wear.



W1322-3A

Figure 2. Typical Type 92B Construction

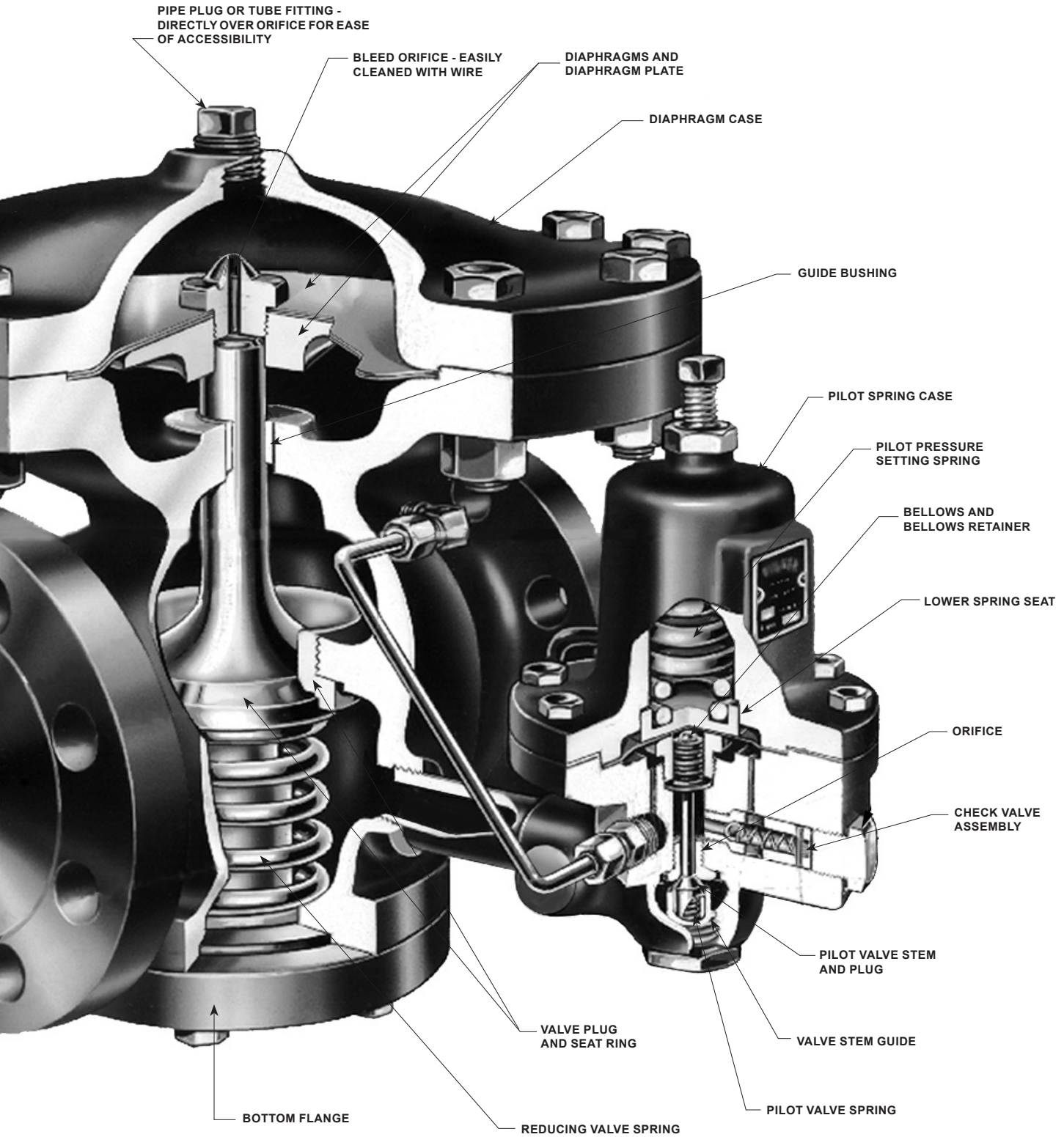

ion

Type 92B

Specifications

This section lists the specifications for the Type 92B Pressure Reducing Valve. The following information is stamped on the nameplate of Type 92B: Type Number, Maximum Outlet Pressure, Maximum Inlet Pressure and Maximum Temperature.

Available Configurations

Pilot-operated globe-style pressure reducing valve with post guiding and flow-to-close valve plug action.

Body Sizes and End Connection Styles

See Table 1

Body Ratings and Maximum Inlet Pressures⁽¹⁾

See Table 3

Minimum Differential Pressures Required for Full Stroke⁽¹⁾

20 psig / 1.4 bar with Stainless steel spring;
10 psig / 0.69 bar with Inconel[®] spring

Maximum Outlet (Casing) Pressure

Cast iron: 150 psig / 10.3 bar or body rating limits, whichever is lower

Steel/Stainless steel: 300 psig / 20.7 bar or body rating limits, whichever is lower

Outlet Pressure Ranges⁽¹⁾

See Table 2

Flow Coefficients

See Table 5

Flow Capacities

See Table 6

Pressure Registration

External

Maximum Temperature Capabilities⁽¹⁾

See Table 3

Downstream Control Line Connections

NPS 1 and 1-1/2 / DN 25 and 40: 1/4 NPT

NPS 2 / DN 50: 3/8 NPT

NPS 3 and 4 / DN 80 and 100: 1/2 NPT

Approximate Weights

See Table 7

Construction Materials

Main Valve

Body, Bottom Flange, Diaphragm Case and Diaphragm Plate: Cast iron, WCC Steel or CF8M Stainless steel

Construction Materials (continued)

Main Valve (continued)

Bottom Flange Gasket: Cast iron: Composition; Steel/Stainless steel: Graphite

Diaphragms: Stainless steel

Valve Plug: 410 or 416 Stainless steel

Seat Ring: 416 Stainless steel (**standard**), 316 Stainless steel (seal weld option)

Valve Plug Guide Bushing: 17-4PH Stainless steel

Spring: 17-7PH Stainless steel or Inconel[®]

Bleed Orifice Fitting: 416 Stainless steel

Pipe Fittings: Steel or Stainless steel

Type 92B Pilot Mounting Parts

Cast iron: Copper tubing and brass fittings

Steel Body: Stainless steel tubing and corrosion resistant steel fittings

Stainless steel Body: Stainless steel tubing and fittings

Type 92B Pilot

Body and Spring Case: Cast iron, WCC steel, CF8M Stainless steel

Diaphragm Plate Assembly: Aluminum, Steel and Stainless steel

Diaphragm Gasket: Cast iron: Composition; Steel/Stainless steel: Graphite

Diaphragm, Valve Guide, and Valve Spring: Stainless steel

Valve Stem and Orifice: 416 Stainless steel

Bellows and Bellows Retainer: Bronze (**standard**) or 321 Stainless steel (high temperature/Stainless steel pilot construction)

Spring: Steel for standard spring and Stainless steel for high temperature spring

Upper Spring Seat: Plated steel for standard construction and Stainless steel for high temperature spring

Lower Spring Seat: Aluminum or Carbon steel

Screen: 304 Stainless steel

Check Valve Assembly: Stainless steel internal with copper housing or all Stainless steel

1. The pressure/temperature limits in this Bulletin or any applicable standard limitation should not be exceeded.

Table 1. Body Sizes and End Connection Styles

BODY SIZES, NPS / DN	END CONNECTION STYLES	
	Cast iron Body	Steel and Stainless steel Body
1 / 25	NPT	NPT, SWE ⁽¹⁾ , CL150 RF, CL300 RF and PN 16/25/40 RF
1-1/2 and 2 / 40 and 50	NPT, CL125 FF and CL250 RF	
3 and 4 / 80 and 100	CL125 FF and CL250 RF	CL150 RF, CL300 RF, PN 16 RF and PN 25/40 RF

1. Available in steel bodies only.

Table 2. Outlet Pressure Ranges

PILOT TYPE	OUTLET PRESSURE		SPRING WIRE DIAMETER		SPRING FREE LENGTH		PART NUMBER	COLOR CODE
	psig	bar	In.	mm	In.	mm		
Low-Pressure	2 to 6	0.14 to 0.41	0.207	5.26	2.50	63.5	1E395627022	Yellow
	5 to 15	0.34 to 1.0	0.234	5.94	2.62	66.5	1D7455T0012	Green
	13 to 25	0.90 to 1.7	0.283	7.19	2.44	62.0	1E395727192	Red
High-Pressure	15 to 30	1.0 to 2.1	0.207	5.26	2.50	63.5	1E395627022	Yellow
	25 to 75	1.7 to 5.2	0.234	5.94	2.62	66.5	1D7455T0012	Green
	70 to 150	4.8 to 10.3	0.281	7.14	2.44	62.0	1E395727192	Red
High Temperature	15 to 100	1.0 to 6.9	0.282	7.16	2.50	63.5	14B9943X012	Unpainted
	80 to 250	5.5 to 17.2	0.375	9.53	2.50	63.5	14B9942X022	Unpainted

Table 3. Maximum Inlet Pressures and Temperatures

BODY MATERIAL	END CONNECTION	MAXIMUM INLET PRESSURE		MAXIMUM TEMPERATURE	
		psig	bar	°F	°C
Cast iron	NPT	250	17.2	406	208
	CL125 FF	125	8.6	353	178
	CL250 RF	250	17.2	406	208
Steel	NPT	300	20.7	450	232
	SWE	300	20.7	450	232
	CL150 RF	185	12.8	450	232
	CL300 RF	300	20.7	600	316 ⁽¹⁾
	PN 16/25/40 RF (NPS 1, 1-1/2, 2 and 3 / DN 25, 40, 50 and 80)	300	20.7	450	232
	PN 16 RF (NPS 4 / DN 100)	185	12.8	450	232
	PN 25/40 RF (NPS 4 / DN 100)	300	20.7	450	232
Stainless steel	NPT	300	20.7	450	232
	CL150 RF	175	12.1	450	232
	CL300 RF	300	20.7	450	232
	PN 16/25/40 RF (NPS 1, 1-1/2, 2 and 3 / DN 25, 40, 50 and 80)	300	20.7	450	232
	PN 16 RF (NPS 4 / DN 100)	175	12.1	450	232
	PN 25/40 RF (NPS 4 / DN 100)	300	20.7	450	232

1. 450°F / 232°C with standard seat ring, 600°F / 316°C with seal weld option.

Table 4. Minimum Differential Pressures for Safety Override System

TYPE	SPRING RANGE		SPRING COLOR	MINIMUM PRESSURE AT WHICH MONITORING PILOT CAN BE SET
	psig	bar		
6492HM	10 to 30	0.69 to 2.1	Yellow	10 psig / 0.69 bar over normal downstream pressure
	25 to 75	1.7 to 5.2	Green	10 psig / 0.69 bar over normal downstream pressure
	70 to 150	4.8 to 10.3	Red	15 psig / 1.0 bar over normal downstream pressure
6492HTM	15 to 100	1.0 to 6.9	Unpainted	10 psig / 0.69 bar over normal downstream pressure
	80 to 250	5.5 to 17.2	Unpainted	25 psig / 1.7 bar over normal downstream pressure

Type 92B

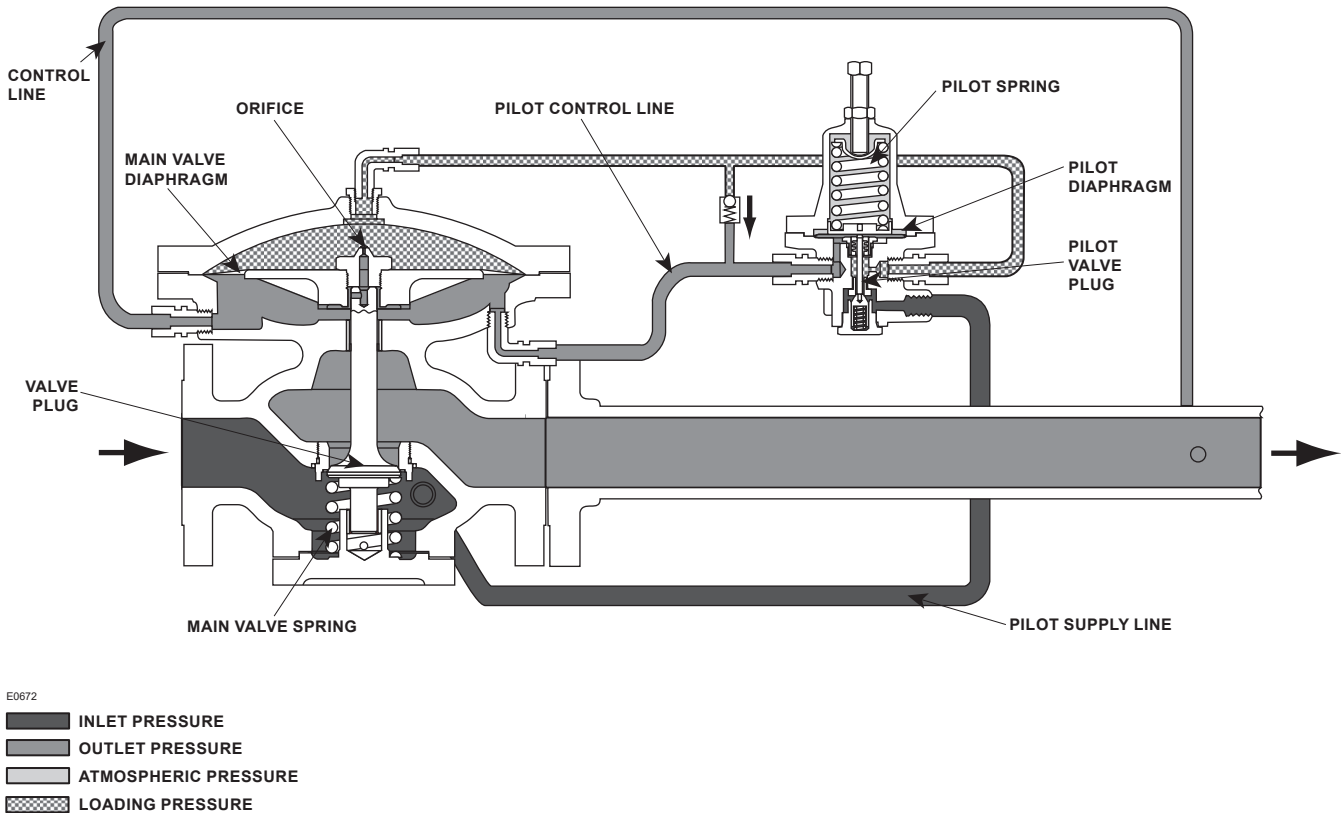

Figure 3. Type 92B Operational Schematic

Principle of Operation

Refer to Figure 3. Compression of the pilot spring pushes diaphragm down and holds pilot valve plug open. Outlet pressure is changed by varying the amount of pilot spring compression.

When steam enters the inlet of the valve, it also enters the pilot supply line and flows through the open pilot valve to the top of the main diaphragm. The force created by this steam pressure on the diaphragm overcomes the force of the main valve spring opening the valve plug and allowing steam to flow downstream. Downstream pressure registers under the main diaphragm through the control line and tends to balance the diaphragm. Steam from the downstream system also registers under the pilot diaphragm through line. Pressure forces the diaphragm upward, permitting the pilot valve plug to move toward the closed position. Flow of steam to the top of the main diaphragm is thereby reduced and the pressure on main diaphragm drops due to the bleed through the orifice. The main valve moves toward the closed position, allowing only enough steam flow to satisfy downstream requirements.

When steam demand increases, the downstream pressure decreases below the setting of the pilot spring. The pilot opens to increase the pressure on the main diaphragm. The main valve opens to increase the flow downstream. Conversely, if the steam demand decreases, the downstream pressure increases and the pilot reacts to decrease the pressure on top of the main diaphragm. The main valve throttles toward the closed position and the steam flow decreases. Thus, through the combination of pilot and main valve operation, control of the downstream steam pressure is maintained.

An internal check valve is included in all Type 92B pilots to limit differential pressure on the main valve diaphragm. In the event of a large decrease in downstream pressure, the check valve opens to relieve diaphragm loading pressure to the downstream system. The check valve cartridge assembly has a factory setting to limit differential pressure across the diaphragm to approximately 40 psid / 2.8 bar d. If diaphragm differential pressure reaches approximately 40 psid / 2.8 bar d, the check valve opens to relieve diaphragm loading pressure into the downstream

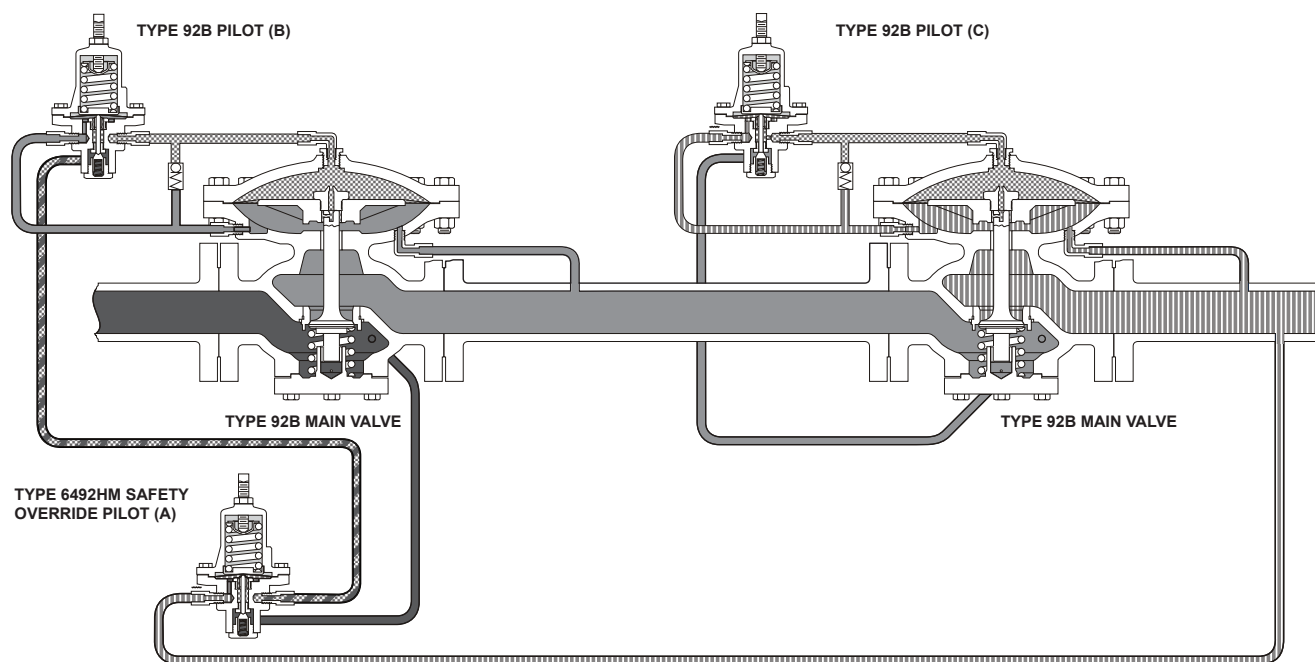

E0794

- INLET PRESSURE
- OUTLET PRESSURE
- ATMOSPHERIC PRESSURE
- LOADING PRESSURE
- INTERMEDIATE PRESSURE

Figure 4. Safety Override System Schematic

system, thereby preventing a high differential across the diaphragm which might otherwise cause diaphragm damage. The check valve closes and normal operation resumes when the differential pressure across the diaphragm is reduced to the proper level.

Safety Override System

Refer to Figure 4. Once placed in operation, the upstream Type 92B pilot (B) senses the intermediate pressure between both valves and the Type 6492HM (A) pilot senses pressure downstream of the second valve. As demand for flow increases, intermediate pressure will fall causing the Type 92B pilot to open. As the Type 92B pilot opens, loading pressure to the main valve increases, opening the main valve.

The Type 6492HM (A) safety override pilot remains open because its setpoint is above the setpoint of the downstream valve. In the unlikely event that the

downstream valve fails open, downstream pressure will rise above the downstream valve's setpoint. This pressure is sensed by the Type 6492HM (A) safety override pilot. As downstream pressure increases the Type 6492HM (A) safety override pilot closes, reducing loading pressure to the upstream main valve, which positions the main valve to maintain desired downstream override pressure.

In the event that the upstream valve fails, the downstream valve will prevent downstream pressure from rising above safe operating levels.

It is recommended to install some type of warning system, such as a sentinel relief valve, to warn the operator that a valve has failed in the system. This will prevent prolonged operation with one valve, which could cause valve trim wear and noise associated with operation at high differential pressures.

Type 92B

Installation

Installation of the Type 92B is dependent on the application. As a minimum, a typical steam pressure reducing station must include a 3-valve bypass, inlet drip leg, inlet strainer (and steam separator if required) and relief valve per ASME Section VIII code. A safety override pressure reducing station can be installed in the event a relief valve is not practical as per ASME B16.122.14 standards, subject to local codes and regulations.

Positioning and Mounting

The Type 92B regulators are intended to be installed with their diaphragm case above the pipeline so that condensate will not collect in the cases. In order to obtain the performance given in this bulletin, connect the downstream end of the control line into a straight run of pipe. The connection should be located at least 6 pipe diameters from the valve body outlet in an unswaged pipeline or 10 pipe diameters from the swage in a swaged pipeline.

The Type 92B pilot should also be installed with the adjusting screw pointing up and the control line should be sloped with a downward pitch to ensure drainage of condensate. The body should be installed so the flow is in the same direction as the arrow on the body.

Note that the Type 92B pilot may be installed on either side of the body.

Overpressure Protection and Relief Valve Sizing

Overpressure protection is required when piping and components downstream of a steam regulating valve have a maximum allowable working pressure (MAWP) that is lower than the upstream supply pressure to the regulating valve. In some cases, the regulating valve itself may have a lower outlet pressure rating than its inlet pressure rating, which will require overpressure protection.

Governing codes and standards define the type and design of overpressure protection. When full flow relief valves are specified, they must relieve a maximum specified flow at a pressure not to exceed that specified by applicable codes. In North America, the governing code for most steam regulating valve installations is ASME Boiler Code, Section VIII, which may be amended by local codes or variances.

The issue in sizing stream relief valves is quantifying its maximum flow rate. Maximum flow conditions may occur under many conditions, so the entire steam system must be analyzed to make sure the maximum relief valve flow is accurate. Failure to do so may cause overpressure.

In applications where it is determined that the steam regulating valve creates maximum flow to the relief valve, several issues must be resolved prior to quantifying the flow to the relief valve.

1. There must be general agreement on the failure mode of the regulating valve. The Emerson Process Management Regulator Technologies, Inc. (Emerson) provides wide-open regulating coefficients to assist with sizing steam relief valves. The coefficients assume that the valve plug is at maximum travel and still in its normal orientation. Contact your local Sales Office prior to relief valve sizing in the event that there is disagreement with the mode of failure.
2. Maximum steam flow must be calculated at the pressure obtained at the relief valve's full-open condition. This pressure is typically larger than a relief valve's set pressure. This pressure must be used as the outlet pressure of the steam regulating valve when calculating the maximum flow through the regulating valve.
3. Maximum steam flow should be calculated from the manufacturer's recommended procedure. The Emerson recommends using either the Fisher™ steam sizing equation or IEC sizing procedure.

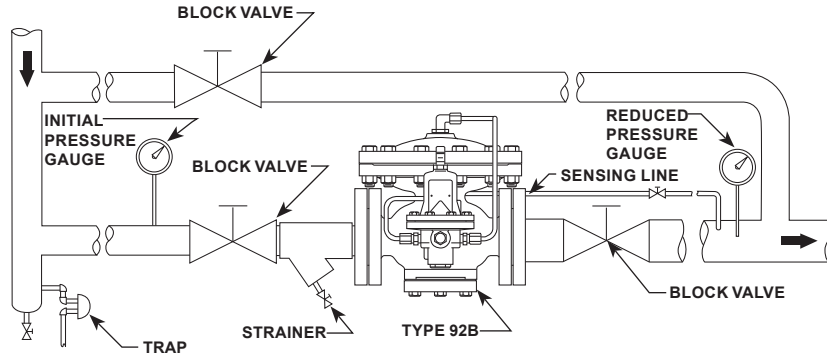

E0706

TYPE 92B SINGLE-STAGE INSTALLATION

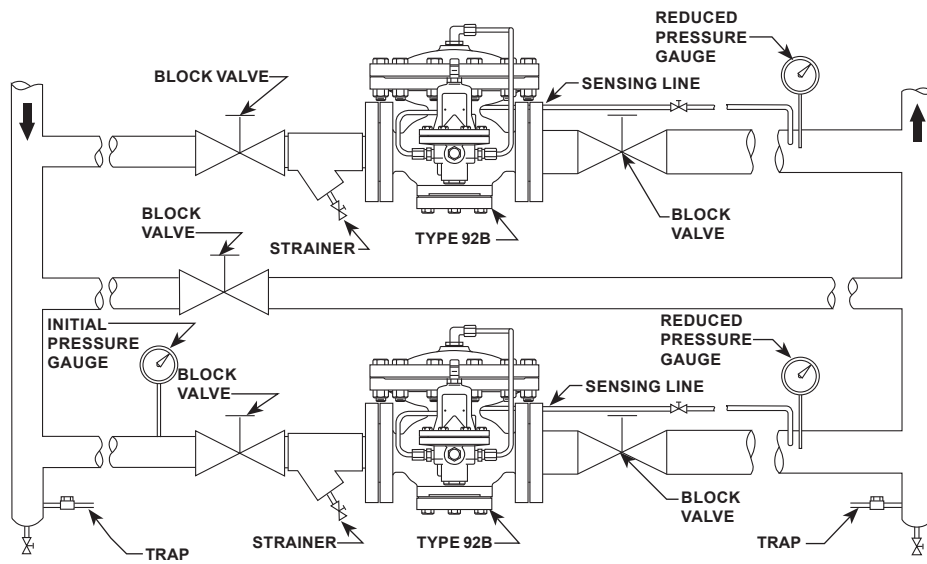

E0707

TYPE 92B SINGLE-STAGE PARALLEL INSTALLATION

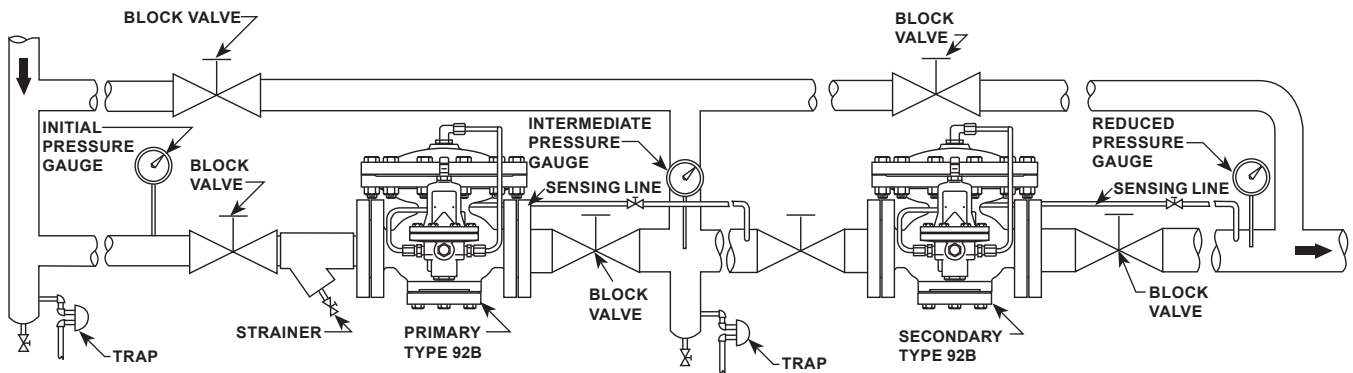

E0708

TYPE 92B TWO-STAGE INSTALLATION

Figure 5. Type 92B Typical Installations

Type 92B

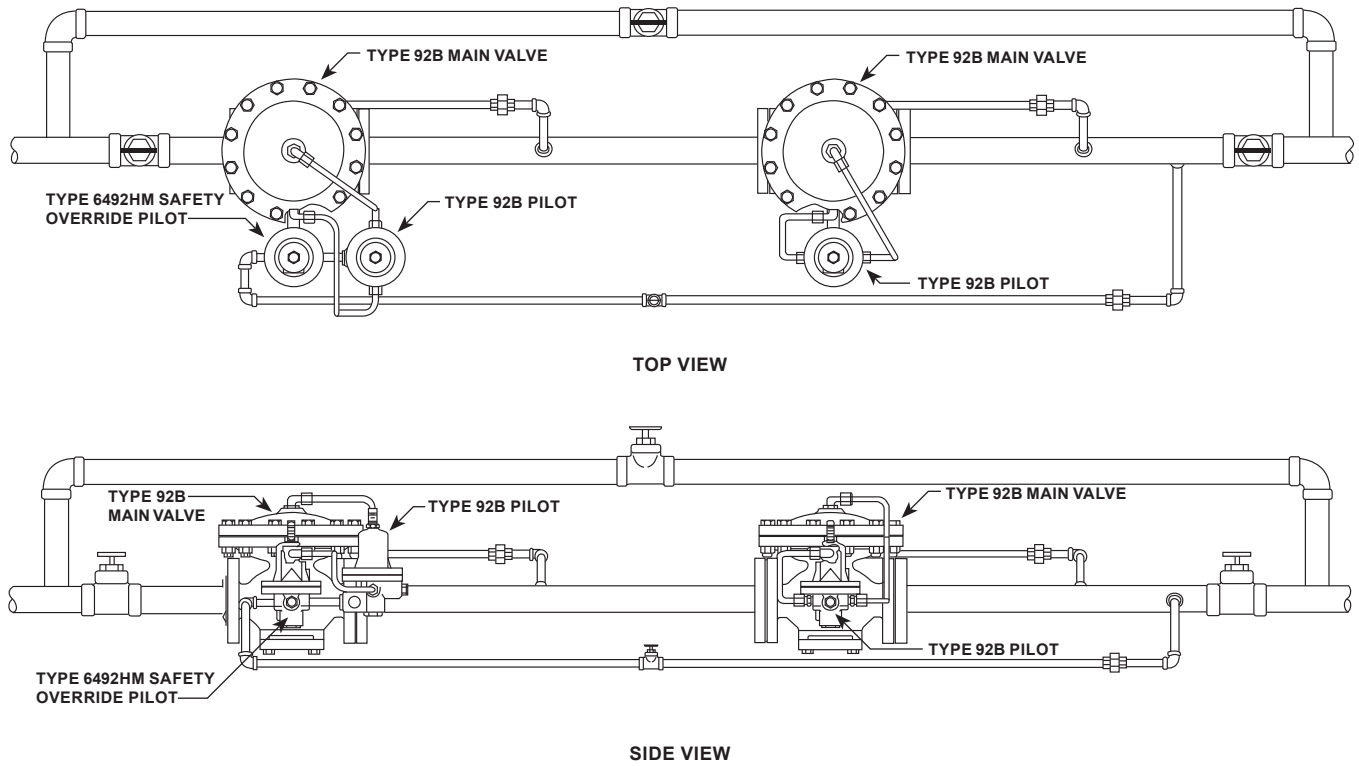
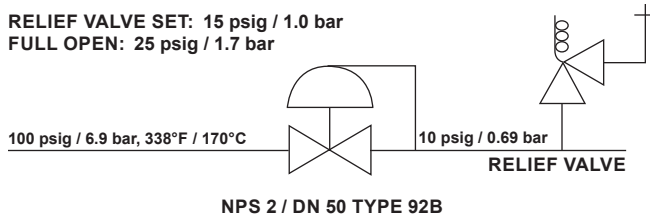

Figure 6. Safety Override System Installation

Example:

RELIEF VALVE SET: 15 psig / 1.0 bar
 FULL OPEN: 25 psig / 1.7 bar



Example Calculation:

$$Q_{\max(\text{lb/hr})} = \left[\frac{74 \times 114.7}{1 + 0.00065 \times 0} \right] \text{SIN} \left[\frac{3417}{35} \sqrt{\frac{75}{114.7}} \right] \text{DEG}$$

$$Q_{\max} = 8,330 \text{ lb/hr} / 3778 \text{ kg/hr}$$

where:

$$C_s = 74 \quad \Delta P = 75 \text{ psia} / 5.2 \text{ bar}$$

$$C_1 = 35 \quad T_{\text{sh}} = 0^\circ \text{F}$$

$$P_1 = 114.7 \text{ psia} / 7.9 \text{ bar}$$

Determine the maximum valve flow capacity at wide-open failure.

$$Q_{\max(\text{lb/hr})} = \left[\frac{C_s P_1}{1 + 0.00065 T_{\text{sh}}} \right] \text{SIN} \left[\frac{3417}{C_1} \sqrt{\frac{\Delta P}{P_1}} \right] \text{DEG}$$

where:

- Q = Steam flow rate, lb/hr
- P₁ = Absolute inlet pressure, psia (P1 gauge + 14.7)
- C_s = Wide-open gas sizing coefficient, see Table 5
- C₁ = Flow coefficient, see Table 5
- T_{sh} = Degrees of steam superheat at inlet, °F
- ΔP = Pressure drop across regulator, psia

Table 5. Main Valve Coefficients

BODY SIZE		FLOW COEFFICIENTS						C ₁	K _m	IEC SIZING COEFFICIENTS		
		Regulating Coefficients			Wide-Open Coefficients					F _L	X _T	F _D
NPS	DN	C _g	C _s	C _v	C _g	C _s	C _v					
1	25	330	16.5	9.4	480	24	13.7	35	0.80	0.89	0.78	0.24
1-1/2	40	560	28	16	921	46	26.3	35	0.80	0.89	0.78	0.25
2	50	960	48	27.4	1481	74	42.3	35	0.80	0.89	0.78	0.28
3	80	2000	100	57.1	3042	152	86.9	35	0.80	0.89	0.78	0.26
4	100	2700	135	77.1	4515	225	129	35	0.80	0.89	0.78	0.20

Table 6. Capacities⁽¹⁾

INLET PRESSURE		OUTLET PRESSURE		CAPACITIES IN lb/h / kg/h OF SATURATED STEAM (BASED ON 10 PERCENT DROOP)									
psig	bar	psig	bar	Body Size									
				NPS 1 / DN 25		NPS 1-1/2 / DN 40		NPS 2 / DN 50		NPS 3 / DN 80		NPS 4 / DN 100	
25	1.7	5	0.34	660	299	1060	481	2060	934	3800	1724	4940	2241
		10	0.69	600	272	1080	490	2080	943	3850	1746	5000	2268
		15	1.0	525	238	935	424	1860	844	3260	1479	4520	2050
50	3.4	5	0.34	1080	490	1830	830	3300	1497	6500	2948	8960	4064
		10	0.69	1080	490	1890	857	3390	1538	6650	3016	9110	4132
		20	1.4	1080	490	1860	844	3290	1492	6500	2948	8810	3996
		30	2.1	928	421	1760	798	2940	1334	5740	2604	7730	3506
		40	2.8	710	322	1660	753	2590	1175	4980	2259	6650	3016
75	5.2	5	0.34	1500	680	2510	1138	4610	2091	9080	4119	10,900	4944
		10	0.69	1500	680	2620	1188	4700	2132	9180	4164	11,200	5080
		20	1.4	1500	680	2720	1234	4770	2164	9290	4214	11,300	5126
		30	2.1	1470	667	2680	1216	4680	2123	8880	4028	10,800	4899
		40	2.8	1380	626	2640	1198	4590	2082	8470	3842	10,200	4627
		50	3.4	1240	562	2380	1080	4370	1982	7680	3484	9240	4191
100	6.9	60	4.1	1020	463	2120	962	4160	1887	6900	3130	8280	3756
		5	0.34	1900	862	3400	1542	5710	2590	11,500	5216	16,100	7303
		10	0.69	1920	871	3440	1560	5870	2663	11,700	5307	16,400	7439
		20	1.4	1920	871	3460	1569	5900	2676	11,800	5352	16,400	7439
		40	2.8	1920	871	3500	1588	5930	2690	11,800	5352	16,500	7484
125	8.6	60	4.1	1700	771	3330	1510	5650	2563	11,000	4990	15,200	6895
		80	5.5	1330	603	2860	1297	4960	2250	9670	4386	13,000	5897
		5	0.34	2310	1048	4140	1878	6950	3152	13,900	6305	19,600	8890
		10	0.69	2340	1061	4170	1892	7010	3180	14,100	6396	19,800	8981
		20	1.4	2340	1061	4230	1919	7080	3211	14,100	6396	19,800	8981
		40	2.8	2340	1061	4280	1941	7080	3211	14,200	6441	19,800	8981
150	10.3	60	4.1	2340	1061	4400	1996	7250	3289	14,400	6532	19,800	8981
		80	5.5	2100	952	4100	1860	6750	3062	13,700	6214	18,500	8392
		100	6.9	1630	739	3250	1474	5400	2449	11,300	5126	15,600	7076
		20	1.4	2770	1256	5000	2268	8220	3728	16,700	7575	23,600	10,705
		40	2.8	2770	1256	5070	2300	8260	3747	16,700	7575	23,700	10,750
		60	4.1	2770	1256	5110	2318	8300	3765	16,800	7620	23,800	10,796
200	13.8	80	5.5	2770	1256	4980	2259	8130	3688	15,900	7212	23,500	10,660
		100	6.9	2360	1070	4600	2086	7740	3511	15,200	6895	21,700	9843
		120	8.3	1950	884	4090	1855	7070	3207	13,700	6214	18,600	8437
		20	1.4	3610	1637	6480	2939	10,700	4854	21,900	9934	29,500	13,381
		40	2.8	3610	1637	6500	2948	10,800	4899	21,900	9934	31,000	14,062
		60	4.1	3610	1637	6520	2957	10,900	4944	22,000	9979	31,200	14,152
200	13.8	80	5.5	3610	1637	6550	2971	11,000	4990	22,500	10,206	31,300	14,198
		100	6.9	3610	1637	6250	2835	10,700	4854	21,700	9843	30,700	13,926
		120	8.3	3280	1488	6300	2858	10,500	4763	20,700	9390	29,700	13,472
		150	10.3	2790	1266	6070	2753	10,200	4628	19,700	8936	28,300	12,837

1. Printed capacities are for the Type 92B with electropneumatic loading system.

Type 92B

Table 6. Capacities⁽¹⁾ (continued)

INLET PRESSURE		OUTLET PRESSURE		CAPACITIES IN lb/h / kg/h OF SATURATED STEAM (BASED ON 10 PERCENT DROOP)									
psig	bar	psig	bar	Body Size									
				NPS 1 / DN 25		NPS 1-1/2 / DN 40		NPS 2 / DN 50		NPS 3 / DN 80		NPS 4 / DN 100	
250	17.2	20	1.4	4460	2023	7850	3561	13,000	5897	27,200	12,338	37,300	16,919
		40	2.8	4460	2023	7920	3592	13,200	5988	27,300	12,383	37,800	17,146
		60	4.1	4460	2023	8100	3674	13,300	6033	27,300	12,383	38,500	17,464
		80	5.5	4460	2023	8130	3688	13,400	6078	27,400	12,429	38,700	17,554
		100	6.9	4460	2023	8150	3697	13,400	6078	27,500	12,474	38,800	17,600
		120	8.3	4160	1887	7860	3565	12,700	5761	26,300	11,930	37,000	16,783
		150	10.3	4050	1837	6780	3075	11,500	5216	23,000	10,433	31,000	14,062
300	21.0	20	1.4	5190	2354	8810	3996	15,100	6849	31,400	14,243	42,400	19,234
		40	2.8	5190	2354	8810	3996	15,100	6849	31,400	14,243	42,400	19,234
		60	4.1	5180	2350	8790	3987	15,000	6804	31,400	14,243	42,300	19,187
		80	5.5	5150	2336	8740	3964	14,900	6759	31,200	14,152	42,100	19,096
		100	6.9	5110	2318	8670	3933	14,800	6713	30,900	14,016	41,800	18,960
		120	8.3	5040	2286	8550	3878	14,600	6623	30,500	13,835	41,200	18,688
		150	10.3	4900	2223	8310	3769	14,200	6441	29,700	13,472	40,000	18,144
		175	12.1	4730	2146	8030	3642	13,700	6214	28,600	12,973	38,700	17,554
		200	13.8	4510	2046	7650	3470	13,100	5942	27,300	12,383	36,800	16,692
		250	17.2	3830	1737	6510	2953	11,100	5035	23,200	10,524	31,400	14,243

1. Printed capacities are for the Type 92B with electropneumatic loading system.

Table 7. Approximate Weights

BODY MATERIAL	END CONNECTION STYLES	BODY SIZE		APPROXIMATE WEIGHTS WITH HIGH-PRESSURE PILOT ⁽¹⁾	
		NPS	DN	lbs	kg
Cast iron	NPT	1	25	55	25
		1-1/2	40	73	33
		2	50	105	48
	CL125 FF	1-1/2	40	77	35
		2	50	110	50
		3	80	175	79
		4	100	243	110
	CL250 RF	1-1/2	40	83	38
		2	50	115	52
		3	80	190	86
		4	100	263	119
	Steel or Stainless steel	NPT	1	25	65
1-1/2			40	89	40
2			50	122	55
CL150 RF, PN 16 RF		1	25	77	35
		1-1/2	40	95	43
		2	50	132	60
		3	80	220	100
CL300 RF, PN 16/25/40 RF, PN 25/40 RF		4	100	285	129
		1	25	82	37
		1-1/2	40	102	46
		2	50	137	62
		3	80	225	102
	4	100	305	138	

1. Add 5 lbs / 2 kg for low-pressure pilot.

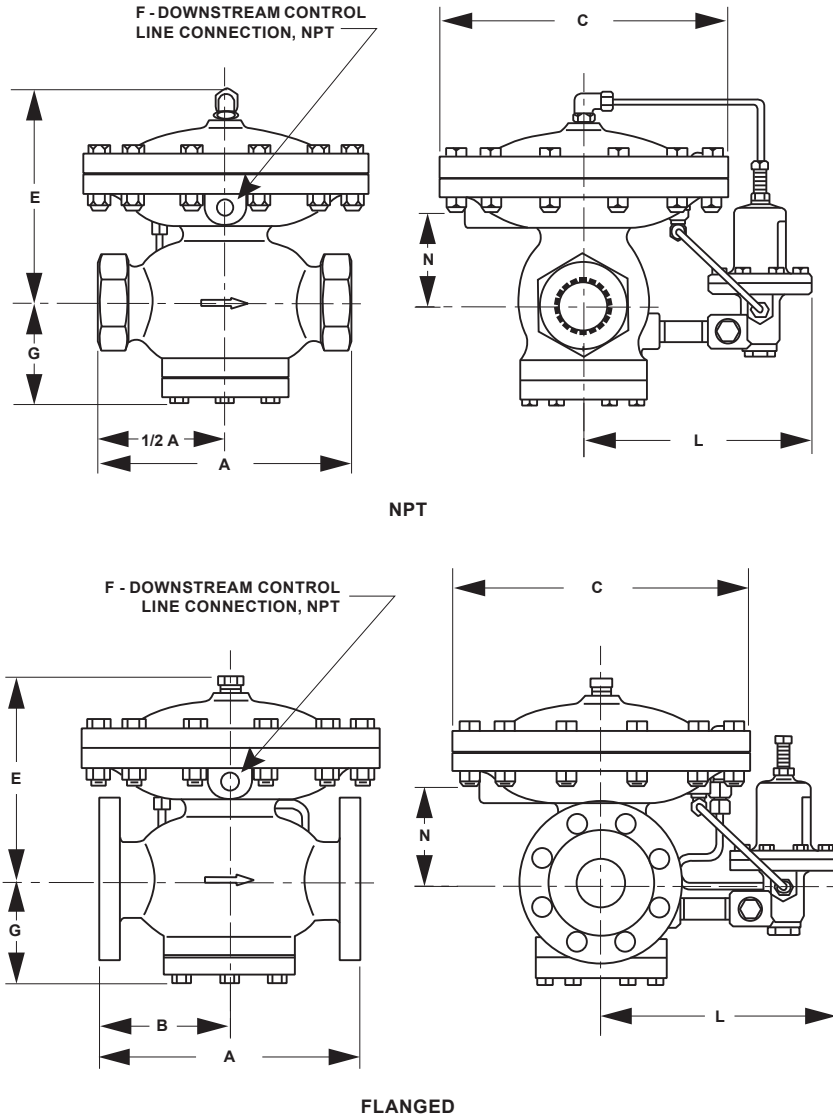

Figure 7. Dimensions

Table 8. Dimensions

BODY SIZE		DIMENSIONS																								
NPS	DN	A										C		E		F NPT	G		N		L					
		NPT		CL125 RF ⁽¹⁾ and CL150 RF		CL250 RF ⁽¹⁾ and CL300 RF		PN 16 RF		PN 25/40 RF		In.	mm	In.	mm		In.	mm	In.	mm	In.	mm	Low-Pressure Pilot		High-Pressure/ High Temp Pilot	
		In.	mm	In.	mm	In.	mm	In.	mm	In.	mm												In.	mm	In.	mm
1	25	6.50	165	7.25	184	7.75	197	7.75	197	7.75	197	9.25	235	6.81	173	1/4	3.25	82.6	2.81	71.4	10.25	260	8.38	213		
1-1/2	40	8.00	203	8.75	222	9.25	235	9.06	230	9.06	230	10.38	264	7.00	178	1/4	3.81	96.8	3.94	100 ⁽²⁾	10.69	272	8.81	224		
2	50	9.25	235	10.00	254	10.50	267	10.25	260	10.25	260	11.88	302	7.75	197	3/8	4.12	105	3.91	99.3	11.25	286	9.38	238		
3	80	----	----	11.75	298	12.50	317	11.81	300	12.21	310	13.88	353	8.94	227	1/2	5.19	132	5.50	140	12.12	308	10.25	260		
4	100	----	----	13.88	353	14.50	368	13.56	344	13.88	353	14.88	378	10.12	257	1/2	6.44	164	6.38	162	13.12	333	11.25	286		

1. Cast iron flanges are not available for the NPS 1 / DN 25 body.
2. 3.44 in. / 87 mm NPT bodies.

Type 92B

Ordering Guide

Inlet Steam Conditions (Select One)

- ≤ 125 psig / 8.6 bar; 353°F / 178°C
- ≤ 175 psig / 12.1 bar; 450°F / 232°C
- ≤ 185 psig / 12.8 bar; 450°F / 232°C
- ≤ 250 psig / 17.2 bar; 406°F / 208°C
- ≤ 300 psig / 20.7 bar; 450°F / 232°C
- ≤ 300 psig / 20.7 bar; 600°F / 316°C

Main Valve Body Size and Material (Select One)

Cast iron

- NPS 1 / DN 25
- NPS 1-1/2 / DN 40
- NPS 2 / DN 50
- NPS 3 / DN 80
- NPS 4 / DN 100

Steel

- NPS 1 / DN 25
- NPS 1-1/2 / DN 40
- NPS 2 / DN 50
- NPS 3 / DN 80
- NPS 4 / DN 100

Stainless steel

- NPS 1 / DN 25
- NPS 1-1/2 / DN 40
- NPS 2 / DN 50
- NPS 3 / DN 80
- NPS 4 / DN 100

End Connection Style (Select One)

Cast iron

- NPT (NPS 1, 1-1/2 and 2)
- CL125 FF Flanged (NPS 1-1/2, 2, 3 and / DN 40, 50, 80 and 100)
- CL250 RF Flanged (NPS 1-1/2, 2, 3 and 4 / DN 40, 50, 80 and 100)

Steel

- NPT (NPS 1, 1-1/2 and 2)
- CL150 RF Flanged
- CL300 RF Flanged
- PN 16/25/40 RF (NPS 1, 1-1/2, 2 and 3 / DN 25, 40, 50 and 80)
- PN 16 RF (NPS 4 / DN 100)
- PN 25/40 RF (NPS 4 / DN 100)

Stainless steel

- NPT (NPS 1, 1-1/2 and 2)
- CL150 RF Flanged
- CL300 RF Flanged
- PN 16/25/40 RF (NPS 1, 1-1/2, 2 and 3 / DN 25, 40, 50 and 80)
- PN 16 RF (NPS 4 / DN 100)
- PN 25/40 RF (NPS 4 / DN 100)

Main Valve Spring (Select One)

- 17-7PH Stainless steel (**standard**)***
- Inconel® (optional)**

Pilot Material (Select One)

- Cast iron
- Steel
- Stainless steel

Pilot Type and Spring Range (Select One)

High-Pressure

- 15 to 30 psig / 1.0 to 2.1 bar, Yellow
- 25 to 75 psig / 1.7 to 5.2 bar, Green
- 70 to 150 psig / 4.8 to 10.3 bar, Black

Low-Pressure

- 2 to 6 psig / 0.14 to 0.41 bar, Yellow
- 5 to 15 psig / 0.34 to 1.0 bar, Green
- 13 to 25 psig / 0.90 to 1.7 bar, Black

- continued -

Inconel® is a mark owned by Special Metals Corporation.

Ordering Guide (continued)

High Temperature

- 15 to 100 psig / 1.0 to 6.9 bar, Unpainted
- 80 to 250 psig / 5.5 to 17.2 bar, Unpainted

Pilot Mounting Position (Select One)

Facing inlet side of main valve with diaphragm case up, pilot is mounted:

- On left side with pilot adjusting screw pointed up
- On right side with pilot adjusting screw pointed up

Options (Select One)

- Standard Adjusting Screw
- Sealed Adjusting Screw
- Handwheel

Safety Override System (Optional)

Type 6492HM Pilot Spring Range

- 10 to 30 psig / 0.69 to 2.1 bar, Yellow
- 25 to 75 psig / 1.7 to 5.2 bar, Green
- 70 to 150 psig / 4.8 to 10.3 bar, Black

Type 6492HTM Pilot Spring Range

- 15 to 100 psig / 1.0 to 6.9 bar, Unpainted
- 80 to 250 psig / 5.5 to 17.2 bar, Unpainted

Main Valve Replacement Parts Kit (Optional)

- Yes, send one main valve replacement parts kit to match this order.

Replacement Pilot (Optional)

- Yes, send one replacement pilot to match this order.

Pilot Replacement Parts Kit (Optional)

- Yes, send one pilot replacement parts kit to match this order.

Regulators Quick Order Guide	
***	Readily Available for Shipment
**	Allow Additional Time for Shipment
*	Special Order, Constructed from Non-Stocked Parts. Consult your local Sales Office for Availability.
Availability of the product being ordered is determined by the component with the longest shipping time for the requested construction.	

Steam Specification Worksheet

Application:
 Tag Number: _____

Valve Type: Direct-Operated Pilot-Operated
 Pressure Loaded Differential

Body Material: Steel Iron Stainless steel

Inlet/Outlet End Connection Style:
 CL125 FF Flange CL150 RF Flange
 CL250 RF Flange CL300 RF Flange
 PN 16/25/40 RF NPT

Inlet/Outlet Pipe Size: _____ In. / mm

Steam Conditions:

	Maximum	Normal	Minimum
Inlet Pressure (psig / bar)			
Inlet Temperature (°F / °C)			
Outlet Pressure (psig / bar)			
Flow (lb/h or kg/h)			

Performance Required:
 Accuracy Requirements: ≤ 10% ≤ 20%
 ≤ 30% ≤ 40%

Type 92B

✉ Webadmin.Regulators@emerson.com

🔍 Fisher.com

📘 Facebook.com/EmersonAutomationSolutions

🌐 LinkedIn.com/company/emerson-automation-solutions

✂️ X.com/emr_automation

Emerson

Americas

McKinney, Texas 75069 USA
T +1 800 558 5853
+1 972 548 3574

Europe

Bologna 40013, Italy
T +39 051 419 0611

Asia Pacific

Singapore 128461, Singapore
T +65 6777 8211

Middle East and Africa

Dubai, United Arab Emirates
T +971 4 811 8100

D101342X012 © 1980, 2025 Emerson Process Management Regulator Technologies, Inc. All rights reserved 02/25.

Fisher™ is a mark owned by Fisher Controls International, LLC, an Emerson Company. The Emerson logo is a trademark and service mark of Emerson Electric Co. All other marks are property of their respective owners.

Neither Emerson nor any of its affiliated entities assume responsibility for the selection, use or maintenance of any product. Responsibility for proper selection, use, and maintenance of any product remains solely with the purchaser and end user.

The contents of this publication are presented for informational purposes only, and while every effort has been made to ensure their accuracy, they are not to be construed as warranties or guarantees, express or implied, regarding the products or services described herein or their use or applicability. All sales are governed by our terms and conditions, which are available upon request. We reserve the right to modify or improve the designs or specifications of such products at any time without notice.

