

Shafer RV-Series

Rotary Vane Valve Actuators

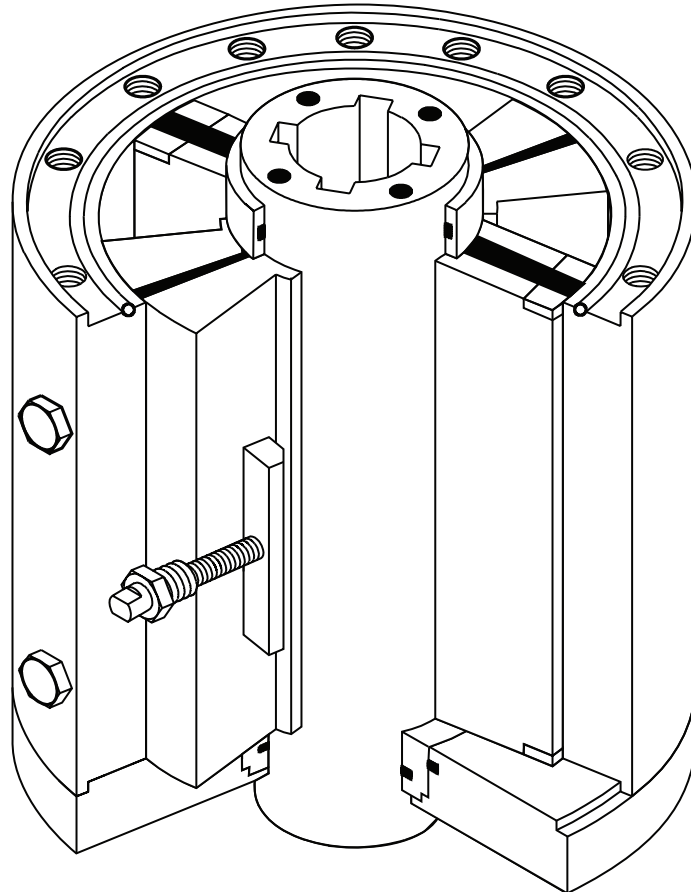

This page is intentionally left blank.

Table of Contents

Section 1: Actuator Specifications

Actuator Specifications 4

Section 2: Dimensional Data

Gas/Hydraulic Rotary Vane - Horizontal Stem, Vertical Line..... 10
Gas/Hydraulic Rotary Vane - Vertical Stem, Horizontal Line..... 11
Central Hydraulic System - Horizontal Stem, Vertical Line..... 12
Central Hydraulic System - Vertical Stem, Horizontal Line..... 13

Actuator Specifications

Note: Gas hydraulic and central hydraulic maximum operating pressures may vary based on control configuration. Bolt circle, rotor bore, keyway quantity and size of mounting holes for RV-Series actuators will be custom fitted to specific valve. All dimension data is subject to change. All dimensions shown in inches.

6-1/2 x 2 Rotary Vane Actuator

- Torque expression: 11.5 in-lb/psi
- Maximum operating pressure: 3000 psi
 - Note:** Consult factory if higher pressure rating required
- Minimum working pressure: 250 psi
- Maximum acceptable valve stem: 2-5/8 in. diameter
- Maximum wrench square: 2 in. across flats
- Weight of actuator including hydraulic fluid: 39 lb
- Actual fluid displacement per 90° stroke equals 21 cu. in.
- On all units equipped with gas hydraulic tanks:
 - Gas consumption per 90° stroke equals 6.3 standard cu. ft. @ 1000 psi
 - Number of strokes of standard 4 cu. in hand pump per 90° stroke equals 6

Figure 1.

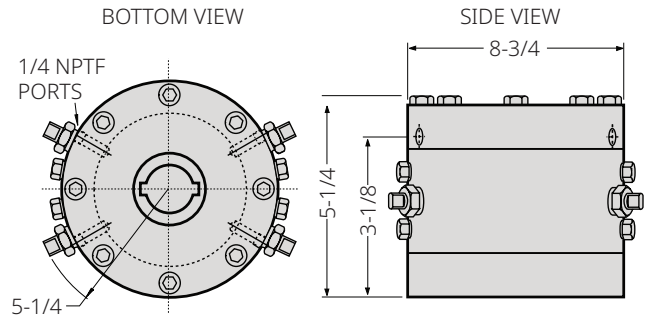

6-1/2 x 3-1/2 Rotary Vane Actuator

- Torque expression: 20 in-lb/psi
- Maximum operating pressure: 3000 psi
 - Note:** Consult factory if higher pressure rating required
- Minimum working pressure: 250 psi
- Maximum acceptable valve stem: 2-5/8 in. diameter
- Maximum wrench square: 2 in. across flats
- Weight of actuator including hydraulic fluid: 94 lb
- Actual fluid displacement per 90° stroke equals 36 cu. in.
- On all units equipped with gas hydraulic tanks:
 - Gas consumption per 90° stroke equals 6.53 standard cu. ft. @ 1000 psi
 - Number of strokes of standard 4 cu. in. hand pump per 90° stroke equals 9

Figure 2.

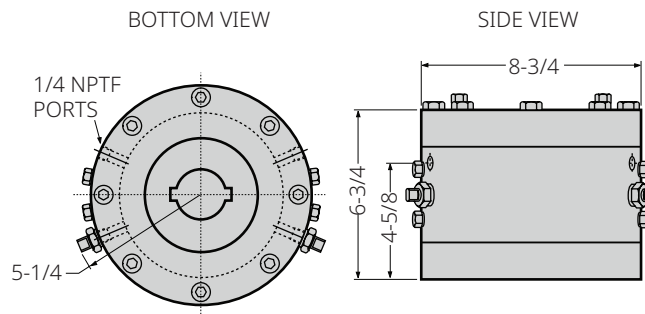

6-1/2 x 8 Rotary Vane Actuator

- Torque expression: 47.3 in-lb/psi
- Maximum operating pressure: 3000 psi
 - Note:** Consult factory if higher pressure rating required
- Minimum working pressure: 250 psi
- Maximum acceptable valve stem: 2-5/8 in. diameter
- Maximum wrench square: 2 in. across flats
- Weight of actuator including hydraulic fluid: 140 lb
- Actual fluid displacement per 90° stroke equals 82 cu. in.
- On all units equipped with gas hydraulic tanks:
 - Gas consumption per 90° stroke equals 8.37 standard cu. ft. @ 1000 psi
 - Number of strokes of standard 4 cu. in. hand pump per 90° stroke equals 21

Figure 3.

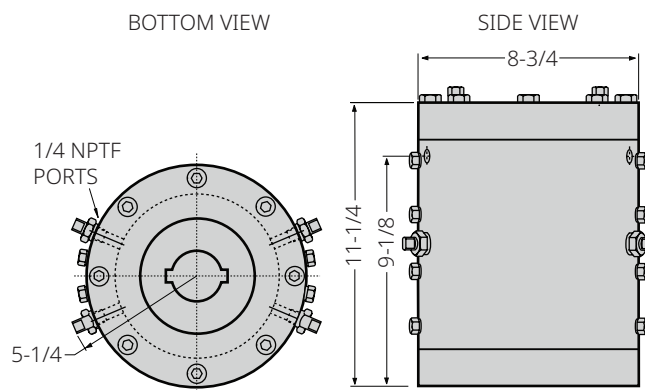

9 x 7 Rotary Vane Actuator

- Torque expression: 72 in-lb/psi
- Maximum operating pressure: 3000 psi
 - Note:** Consult factory if higher pressure rating required
- Minimum working pressure: 250 psi
- Maximum acceptable valve stem: 3-3/4 in. diameter
- Maximum wrench square: 2-1/2 in. across flats
- Weight of actuator including hydraulic fluid: 230 lb
- Actual fluid displacement per 90° stroke equals 125 cu. in.
- On all units equipped with gas hydraulic tanks:
 - Gas consumption per 90° stroke equals 12.5 standard cu. ft. @ 1000 psi
 - Number of strokes of standard 4 cu. in. hand pump per 90° stroke equals 32

Figure 4.

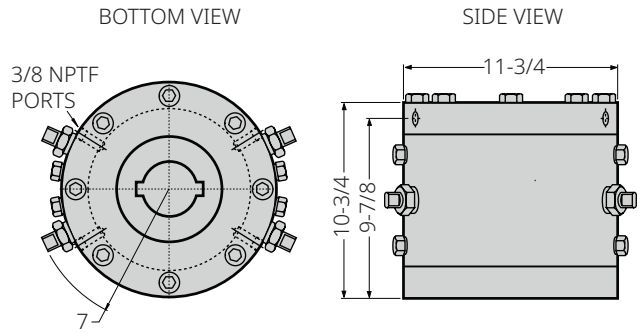

9 x 12 Rotary Vane Actuator

- Torque expression: 128.5 in-lb/psi
- Maximum operating pressure: 3000 psi
 - Note:** Consult factory if higher pressure rating required
- Minimum working pressure: 250 psi
- Maximum acceptable valve stem: 3-3/4 in. diameter
- Maximum wrench square: 2-1/2 in. across flats
- Weight of actuator including hydraulic fluid: 347 lb
- Actual fluid displacement per 90° stroke equals 225 cu. in.
- On all units equipped with gas hydraulic tanks:
 - Gas consumption per 90° stroke equals 22.5 standard cu. ft. @ 1000 psi
 - Number of strokes of standard 4 cu. in. hand pump per 90° stroke equals 57

Figure 5.

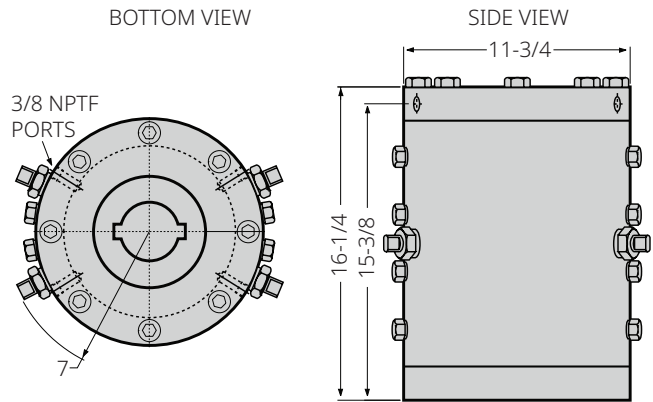

12-1/2 x 8 Rotary Vane Actuator

- Torque expression: 186.77 in-lb/psi
- Maximum operating pressure: 2000 psi
 - Note:** Consult factory if higher pressure rating required
- Minimum working pressure: 250 psi
- Maximum acceptable valve stem: 4-1/2 in. diameter
- Maximum wrench square: 3-1/4 in. across flats
- Weight of actuator including hydraulic fluid: 500 lb
- Actual fluid displacement per 90° stroke equals 327 cu. in.
- On all units equipped with gas hydraulic tanks:
 - Gas consumption per 90° stroke equals 32.6 standard cu. ft. @ 1000 psi
 - Number of strokes of standard 4 cu. in. hand pump per 90° stroke equals 82

Figure 6.

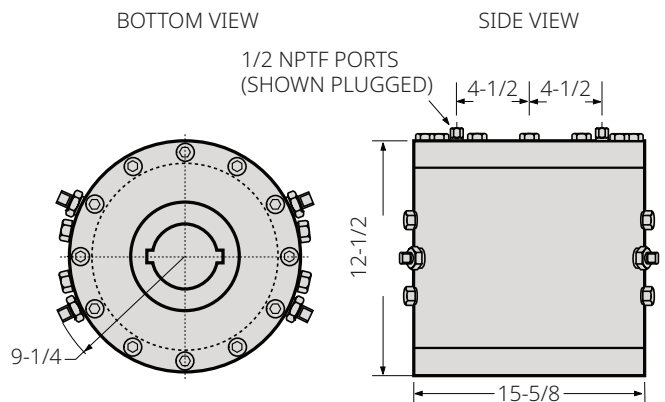

12-1/2 x 12 Rotary Vane Actuator

- Torque expression: 288 in-lb/psi
- Maximum operating pressure: 2000 psi
 - Note:** Consult factory if higher pressure rating required
- Minimum working pressure: 250 psi
- Maximum acceptable valve stem: 4-1/2 in. diameter
- Maximum wrench square: 3-1/4 across flats
- Weight of actuator including hydraulic fluid: 660 lb
- Actual fluid displacement per 90° stroke equals 490 cu. in.
- On all units equipped with gas hydraulic tanks:
 - Gas consumption per 90° stroke equals 48.9 standard cu. ft. @ 1000 psi
 - Number of strokes of standard 4 cu. in. hand pump per 90° stroke equals 123

14-1/2 x 16 Rotary Vane Actuator

- Torque expression: 522 in-lb/psi
- Maximum operating pressure: 2000 psi
 - Note:** Consult factory if higher pressure rating required
- Minimum working pressure: 250 psi
- Maximum acceptable valve stem: 5-1/2 in. diameter
- Weight of actuator including hydraulic fluid: 1064 lb
- Actual fluid displacement per 90° stroke equals 913 cu. in.
- On all units equipped with gas hydraulic tanks:
 - Gas consumption per 90° stroke equals 91.2 standard cu. ft. @ 1000 psi
 - Number of strokes of standard 12 cu. in. hand pump per 90° stroke equals 76

16-1/2 x 16 Rotary Vane Actuator

- Torque expression: 688.5 in-lb/psi
- Maximum operating pressure: 2000 psi
 - Note:** Consult factory if higher pressure rating required
- Minimum working pressure: 250 psi
- Maximum acceptable valve stem: 6 in. diameter
- Weight of actuator including hydraulic fluid: 1325 lb
- Actual fluid displacement per 90° stroke equals 1280 cu. in.
- On all units equipped with gas hydraulic tanks:
 - Gas consumption per 90° stroke equals 127.8 standard cu. ft. @ 1000 psi
 - Number of strokes of standard 12 cu. in. handpump per 90° stroke equals 107

Figure 7.

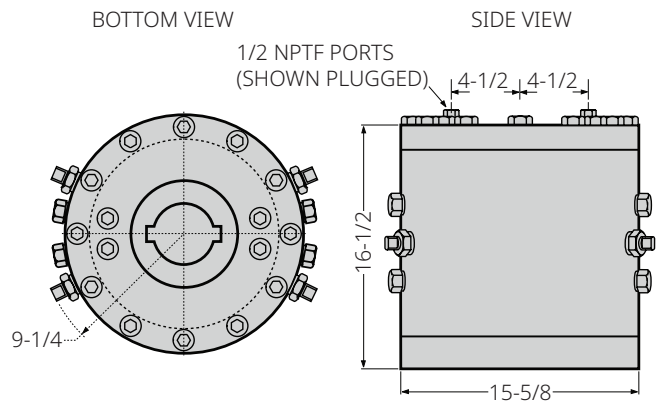

Figure 8.

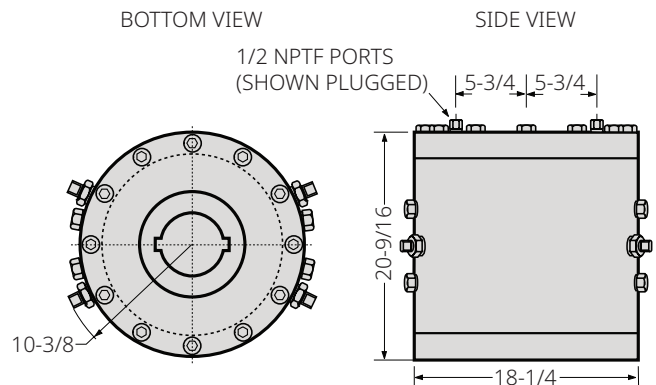
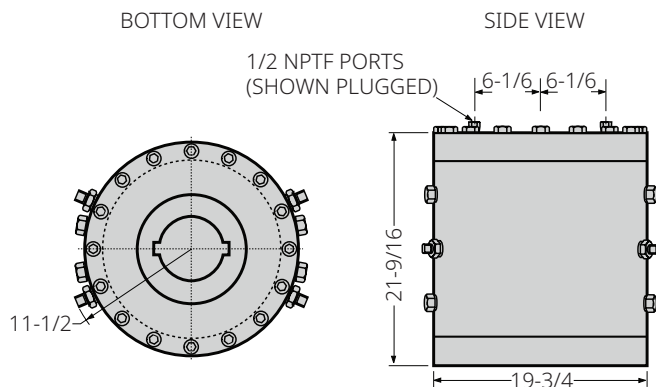

Figure 9.



20 x 16 Rotary Vane Actuator

- Torque expression: 1148.4 in-lb/psi
- Maximum operating pressure: 1500 psi
 - Note:** Consult factory if higher pressure rating required
- Minimum working pressure: 250 psi
- Maximum acceptable valve stem: 6 in. diameter
- Weight of actuator including hydraulic fluid: 1880 lb
- Actual fluid displacement per 90° stroke equals 2013 cu. in.
- On all units equipped with gas hydraulic tanks:
 - Gas consumption per 90° stroke equals 201 standard cu. ft. @ 1000 psi
 - Number of strokes of standard 12 cu. in. hand pump per 90° stroke equals 168

Figure 10.

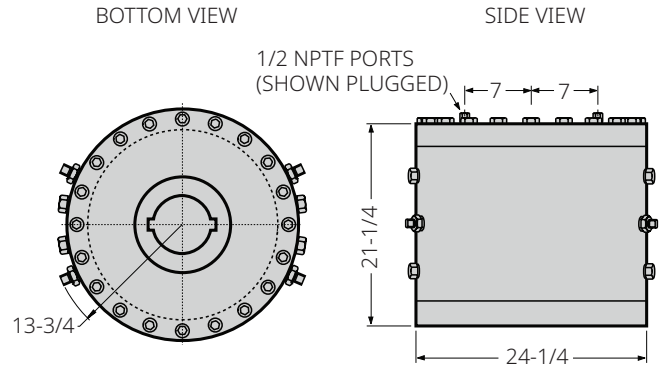

25 x 16 Rotary Vane Actuator

- Torque expression: 1853.1 in-lb/psi
- Maximum operating pressure: 1500 psi
 - Note:** Consult factory if higher pressure rating required
- Minimum working pressure: 250 psi
- Maximum acceptable valve stem: 6-1/2 in. diameter
- Weight of actuator including hydraulic fluid: 2920 lb
- Actual fluid displacement per 90° stroke equals 3232 cu. in.
- On all units equipped with gas hydraulic tanks:
 - Gas consumption per 90° stroke equals 322.8 standard cu. ft. @ 1000 psi
 - Number of strokes of standard 12 cu. in. hand pump per 90° stroke equals 270

Figure 11.

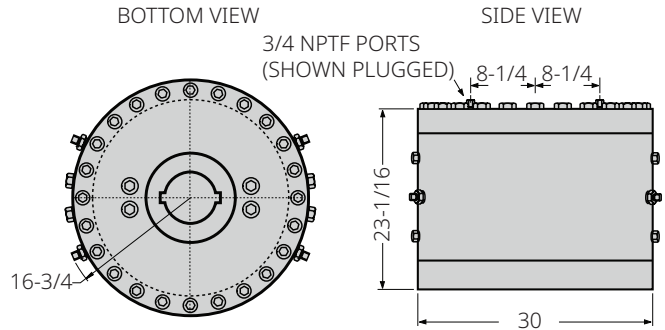

26 x 22 Rotary Vane Actuator

- Torque expression: 2691.5 in-lb/psi
- Maximum operating pressure: 1500 psi
 - Note:** Consult factory if higher pressure rating required
- Minimum working pressure: 250 psi
- Maximum acceptable valve stem: 7-3/8 in. diameter
- Weight of actuator including hydraulic fluid: 4050 lb
- Actual fluid displacement per 90° stroke equals 4697 cu. in.
- On all units equipped with gas hydraulic tanks:
 - Gas consumption per 90° stroke equals 469.1 standard cu. ft. @ 1000 psi
 - Number of strokes of standard 12 cu. in. hand pump per 90° stroke equals 392

Figure 12.

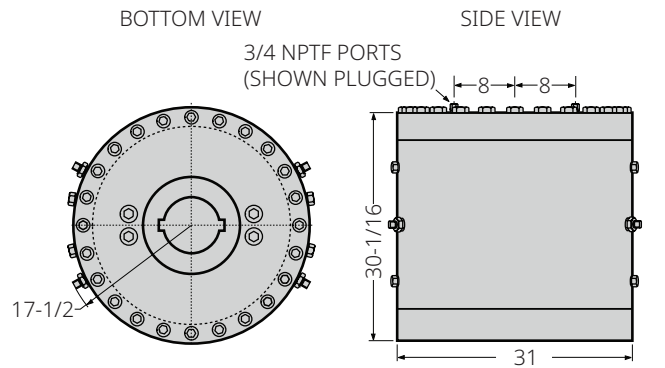

26 x 36 Rotary Vane Actuator

- Torque expression: 4338 in-lb/psi
- Maximum operating pressure: 1500 psi
 - Note:** Consult factory if higher pressure rating required
- Minimum working pressure: 250 psi
- Maximum acceptable valve stem: 7-3/8 in. diameter
- Weight of actuator including hydraulic fluid: 7687 lb
- Actual fluid displacement per 90° stroke equals 7686 cu. in.
- On all units equipped with gas hydraulic tanks:
 - Gas consumption per 90° stroke equals 767.6 standard cu. ft. @ 1000 psi
 - Number of strokes of standard 12 cu. in. hand pump per 90° stroke equals 641

33 x 32 Rotary Vane Actuator

- Torque expression: 5868 in-lb/psi
- Maximum operating pressure: 1500 psi
 - Note:** Consult factory if higher pressure rating required
- Minimum working pressure: 250 psi
- Maximum acceptable valve stem: 9-1/2 in. diameter
- Weight of actuator including hydraulic fluid: 8900 lb
- Actual fluid displacement per 90° stroke equals 10857 cu. in.
- On all units equipped with gas hydraulic tanks:
 - Gas consumption per 90° stroke equals 1084.2 standard cu. ft. @ 1000 psi
 - Number of strokes of standard 12 cu. in. hand pump per 90° stroke equals 905

Figure 13.

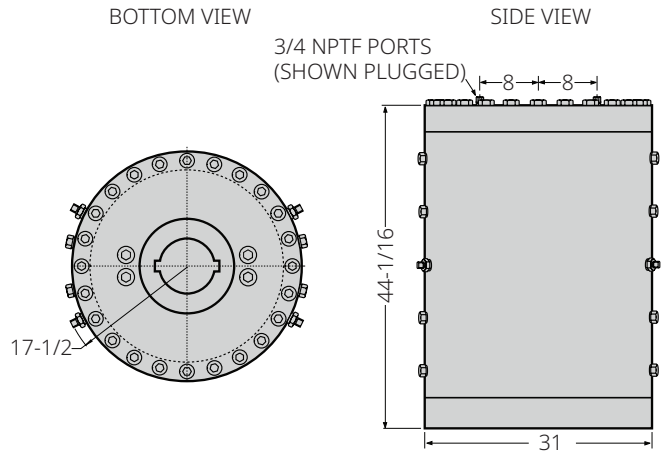

Figure 14.

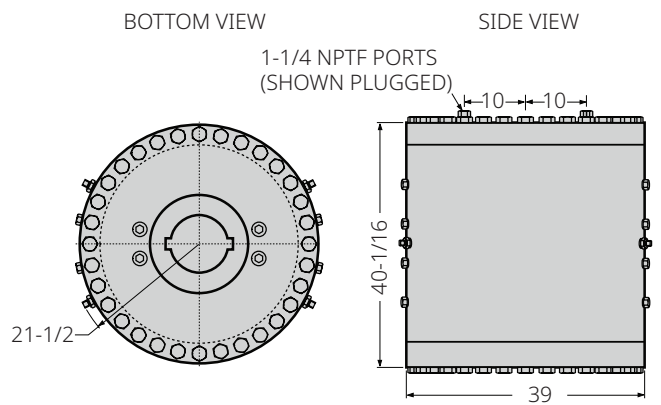

Table 1. Speed of Operation in Seconds Per 90° Rotation*

Actuator Size	Operating Pressure (psig)											
	300	400	500	600	700	800	900	1000	1100	1200	1300	1400
6-1/2 x 2	4	4	3	3	3	2	2	2	2	2	1	1
6-1/2 x 3-1/2	5	5	4	3	3	3	2	2	2	2	1	1
6-1/2 x 8	6	6	5	4	4	4	3-1/2	3-1/2	3	3	2	1
9 x 7	9	8	8	7	5	5	5	5	3	3	2	2
9 x 12	11	10	9	9	8	7	6	6	5	4	4	3
12-1/2 x 8	12	11	11	10	9	9	8	8	7	6	6	6
12-1/2 x 12	18	16	15	13	10	10	10	10	9	9	9	9
14-1/2 x 16	20	18	16	14	14	12	12	12	12	11	11	11
16-1/2 x 16	28	23	20	19	17	16	15	15	15	15	15	14
20 x 16	30	25	24	22	20	20	20	19	19	19	19	18
25 x 16	43	37	33	30	25	25	24	24	24	24	22	22
26 x 22	50	40	35	30	25	25	25	25	25	25	25	25
26 x 36	70	50	45	40	38	35	35	35	-	-	-	-
33 x 32	146	125	111	102	95	88	83	79	-	-	-	-

NOTE:

* Stroking speeds above are approximate as speed may be affected by fluid viscosity or the flow capacities of the individual control components. The listed speeds are based on actuators with gas hydraulic tanks, hand pump and the standard poppet type control block in the power supply circuit. Adjustable speed control valves may be specified so that the stroking speed may be fine tuned to the field operating conditions. If faster speeds are required, please consult a factory representative.

Table 2. Approximate Weights for Shafer Rotary Operators, Hydraulic Tanks and Power Storage Tanks

Size	Operator Weight (lb)	Hydraulic Tank Weight (lb) (per pair)	Power Storage Tank (standard) Weight (lb)
6-1/2 x 2	39	35	20
6-1/2 x 3-1/2	100	35	20
6-1/2 x 8	150	75	40
9 x 7	275	111	52
9 x 12	400	170	85
12-1/2 x 8	500	265	125
12-1/2 x 12	660	406	175
14-1/2 x 16	1064	675	275
16-1/2 x 16	1325	875	450
20 x 16	1880	1275	693
25 x 16	2920	2708	1181
26 x 22	4500	3348	1450
26 x 36	7687	5362	2315
33 x 32	8900	7448	3160

Table 3. Approximate Weights for Shafer Hand Pumps, 2-Way Electric Controls and Limit Switches

Pumps	Control (Two-Way Electric)	Limit Switch
4 cu. in. = 20 lb	1/4 in. = 60 lb	LARGE = 25 lb
12 cu. in. = 44 lb	1/2 in. = 75 lb	-

4 cu. in. Pump, 1/4 Poppet Block = 52 lb + Cover 28 lb = Total 80 lb
 12 cu. in. Pump, 1/4 Poppet Block = 102 lb + Cover 42 lb = Total 144 lb
 Linebreak Small Plate with Lockout = 42 lb + Cover 22 lb = 64 lb

4 cu. in. Pump/D.H.V. = 50 lb
 12 cu. in. Pump/D.H.V. = 110 lb

Limit Valve (ESD) with Plate 10 lb
 1-08672 Terminal Box = 10 lb
 1-09027 Terminal Box = 12 lb
 1/4 Poppet Block, 4 cu. in. pump and linebreak with cover = 95 lb

Dimensional Data

Gas/Hydraulic Rotary Vane - Horizontal Stem, Vertical Line

Note: All dimensional data is for reference only and subject to change. Depending on the application, specific actuator controls may or may not be located inside of the control box. Where specified, there may be additional pressure vessels or power storage tanks which are not shown.

Figure 15.

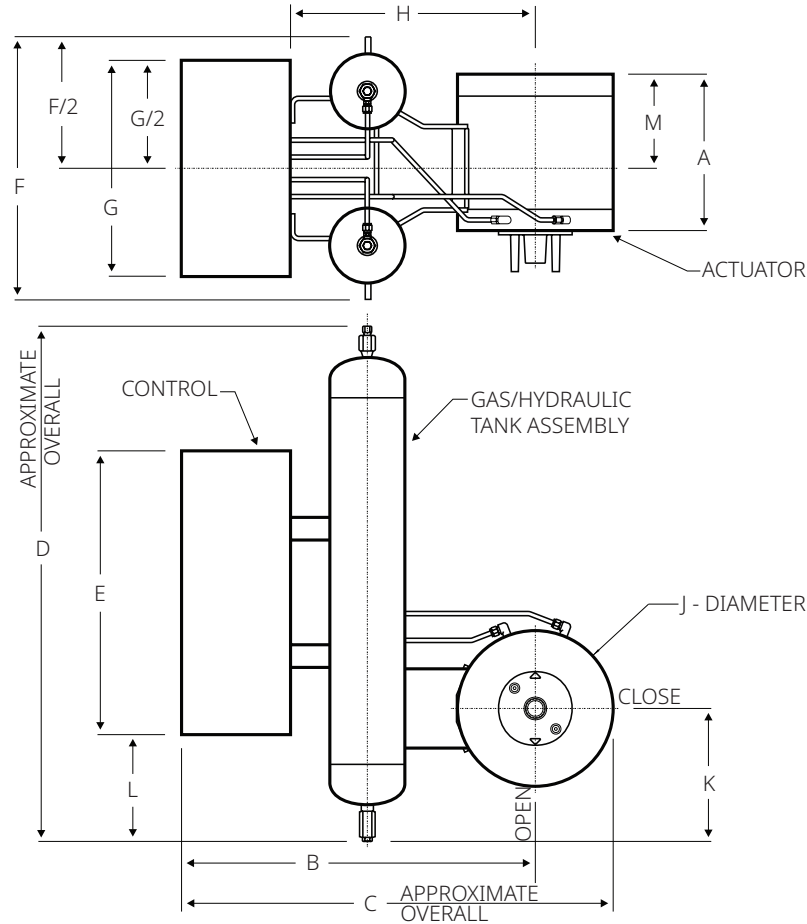

Table 4.

Size	A	B	C	D	E	F	G	H	J	K	L	M
6-1/2 x 2	5-1/4	24-1/2	29	23 1/4	25-1/4	18-1/4	19-1/4	16-1/4	8-3/4	9-1/4	1/2	2-1/4
6-1/2 x 3-1/2	6-3/4	24-1/2	29	23 1/4	25-1/4	18-1/4	19-1/4	16-1/4	8-3/4	9-1/4	1/2	3-3/4
6-1/2 x 8	11-1/4	24-1/2	29	30	25-1/4	18-1/4	19-1/4	16-1/4	8-3/4	9-1/4	4-3/4	6-1/2
9 x 7	10-3/4	29-3/4	35-1/2	30-3/4	25-1/4	21-1/4	19-1/4	21-1/4	11-3/4	10-3/4	4-1/4	5-1/2
9 x 12	16-1/4	30-1/2	36-1/4	37-1/2	25-1/4	23-1/4	19-1/4	22	11-3/4	11 3/4	7-1/2	11
12-1/2 x 8	12-1/2	32-1/2	39-1/4	45-1/4	25-1/4	23-1/4	19-1/4	24	15-3/4	11-3/4	11-1/2	7-1/2
12-1/2 x 12	17	33-3/4	41-1/2	42	25-1/4	27-1/4	19-1/4	25-1/4	15-3/4	12-1/4	10	10-3/4
14-1/2 x 16	20-9/16	44-1/2	53-1/2	47	32-1/2	33-1/2	23	32	18-1/4	16-1/2	7	9-1/4
16-1/2 x 16	22-1/2	45-3/4	55-3/4	60-1/4	32-1/2	33-1/2	23	33-1/2	19-3/4	16-1/2	13-1/4	10-3/4
20 x 16	23-1/4	49-1/2	61-1/2	58	32-1/2	40	23	37	24-1/4	17-1/2	12-1/4	10-1/2
25 x 16	24-3/4	51-1/4	66-1/4	67-3/4	36-1/4	44	25-1/4	37-1/2	30	11-1/2	17-1/4	10-1/4
26 x 22	32-1/4	*	*	*	36-1/4	*	25-1/4	*	31	*	*	*
26 x 36	45-1/2	*	*	*	36-1/4	*	25-1/4	*	31	*	*	*
33 x 32	41-1/4	*	*	*	36-1/4	*	25-1/4	*	39	*	*	*

NOTE:

* Indicates this particular size of actuator has not been used in this type of application. All dimensions shown in inches.

Gas/Hydraulic Rotary Vane - Vertical Stem, Horizontal Line

Note: All dimensional data is for reference only and subject to change. Depending on the application, specific actuator controls may or may not be located inside of the control box. Where specified, there may be additional pressure vessels or power storage tanks which are not shown.

Figure 16.

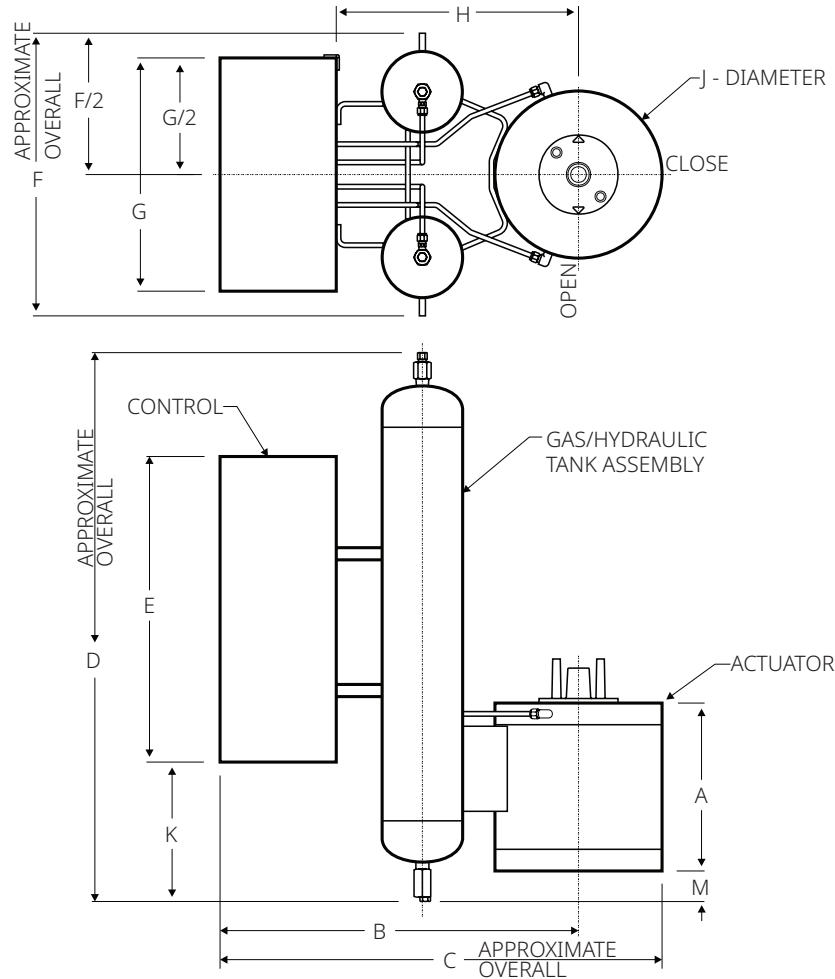

Table 5.

Size	A	B	C	D	E	F	G	H	J	K	M
6-1/2 x 2	5-1/4	24-1/4	28-1/2	23-1/4	25-1/4	18-1/4	19-1/4	15-3/4	8-3/4	1/2	5-1/4
6-1/2 x 3-1/2	6-3/4	24-1/4	28-1/2	23-1/4	25-1/4	18-1/4	19-1/4	15-3/4	8-3/4	1/2	5
6-1/2 x 8	11-1/4	24-1/4	28-1/2	30	25-1/4	18-1/4	19-1/4	15-3/4	8-3/4	4-3/4	3-1/4
9 x 7	10-3/4	27-1/2	33-1/2	30-3/4	25-1/4	21-1/4	19-1/4	19-1/4	11-3/4	4-1/4	5
9 x 12	16-1/4	28-1/2	34-1/4	37-1/2	25-1/4	23-1/4	19-1/4	20	11-3/4	7-1/2	3-1/2
12-1/2 x 8	12-1/2	32	39-3/4	45-1/4	25-1/4	23-1/4	19-1/4	23-1/2	15-3/4	9	2-1/2
12-1/2 x 12	17	32	39-3/4	42	25-1/4	27-1/4	19-1/4	23-1/2	15-3/4	10	3/4
14-1/2 x 16	20-9/16	38-3/4	47-3/4	47	32-1/2	33-1/2	23	26-1/4	18-1/4	7	5-1/4
16-1/2 x 16	22-1/2	40	50	60-1/4	32-1/2	33-1/2	23	27-3/4	19-3/4	13-1/4	1-1/4
20 x 16	23-1/4	44-1/4	56-1/4	58	32-1/2	40	23	31-3/4	24-1/4	12-1/4	6-1/2
25 x 16	24-1/2	51	66	67-3/4	36-1/2	44	25-1/4	36-1/2	30	13-1/2	9-1/4
26 x 22	32	37	68	84-1/4	36-1/2	48	25-1/4	38	31	21-3/4	6-3/4
26 x 36	45-1/4	58	73-1/2	69-1/2	36-1/2	57	25-1/4	43-1/2	31	13-1/4	8-1/2
33 x 32	41-1/4	62-1/4	81-3/4	97-1/2	36-3/4	57	25-1/4	47-3/4	39	28-1/4	10-3/4

NOTE:

* Indicates this particulat size of actuator has not been used in this type of application. All dimensions shown in inches.

Central Hydraulic System - Horizontal Stem, Vertical Line

Note: All dimensional data is for reference only and subject to change. Depending on the application, specific actuator controls may or may not be located inside of the control box. Where specified, there may be additional pressure vessels or power storage tanks which are not shown.

Figure 17.

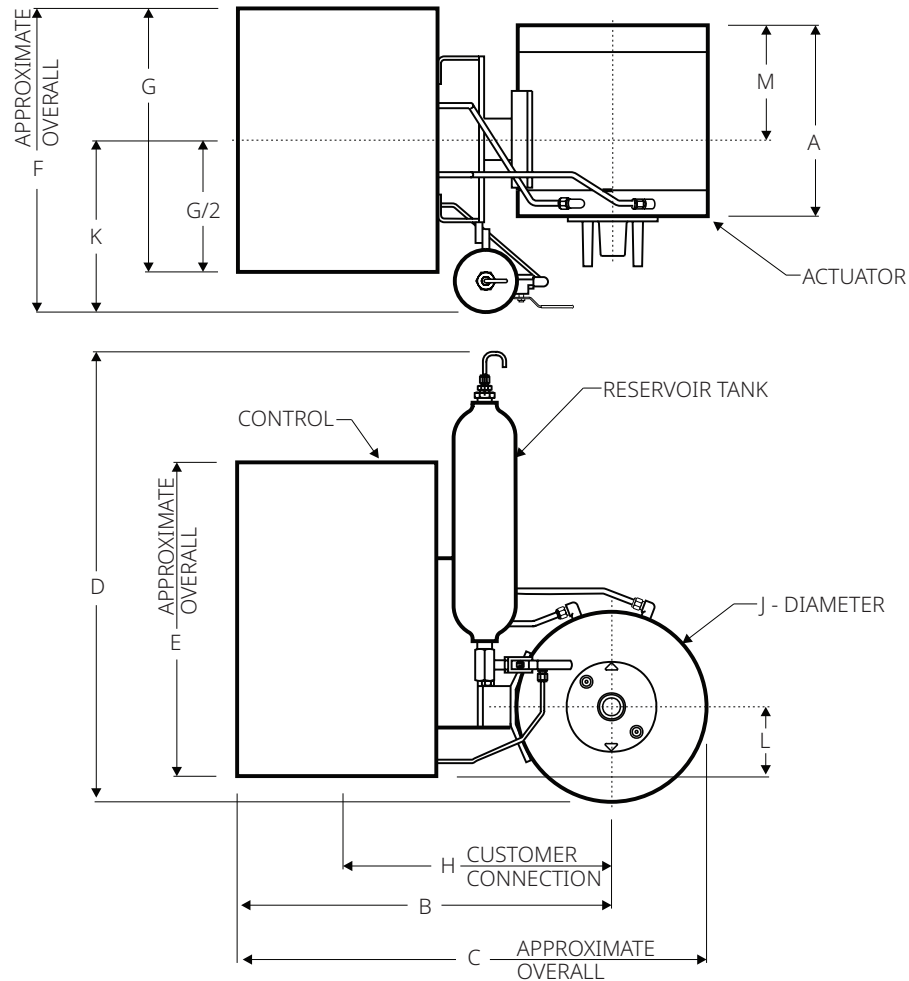

Table 6.

Size	A	B	C	D	E	F	G	H	J	K	L	M
6-1/2 x 2	5-1/4	23-1/2	27	30-3/4	22-3/4	22	19-1/4	17	8-3/4	12-1/2	4-1/2	2-1/4
6-1/2 x 3-1/2	6-3/4	24-3/4	29	30-3/4	22-3/4	22	19-1/4	17	8-3/4	12-1/2	4-1/2	3-3/4
6-1/2 x 8	11-1/4	24-3/4	29	30-3/4	22-3/4	22	19-1/4	17	8-3/4	12-1/2	4-1/2	6-1/2
9 x 7	10-3/4	26-1/4	32	31-1/2	22-3/4	22	19-1/4	18-1/2	11-3/4	12-1/2	5	5-1/4
9 x 12	16-1/4	26-1/4	32	31-1/2	22-3/4	22-1/2	19-1/4	18-1/2	11-3/4	12-1/2	5	10-3/4
12-1/2 x 8	12-1/2	28	36	32-1/2	22-3/4	23-1/4	19-1/4	20-1/2	15-3/4	12-1/2	5	8-3/4
12-1/2 x 12	17	28	36	33-1/2	22-3/4	23-1/4	19-1/4	20-1/2	15-3/4	12-1/2	5	10-3/4
14-1/2 x 16	20-9/16	34-1/4	43-1/4	34-3/4	32-1/2	26-1/2	28-1/4	23-1/4	18-1/4	12-1/2	9	9-1/4
16-1/2 x 16	22-1/2	35	45	35-1/2	32-1/2	26-1/2	28-1/4	24	19-3/4	12-1/2	9	10-3/4
20 x 16	23-1/4	37-1/2	49-3/4	37-3/4	32-1/2	26-1/2	28-1/4	26-1/2	24-1/4	12-1/2	9	10-1/2
25 x 16	24-1/2	36-3/4	51-3/4	46	36-1/2	25	25-1/4	28-3/4	30	12-1/2	5-1/2	12-1/4
26 x 22	32	*	*	*	36-1/2	*	25-1/4	*	31	*	*	*
26 x 36	45-1/4	*	*	*	36-1/2	*	25-1/4	*	31	*	*	*
33 x 32	41-1/4	*	*	*	36-1/2	*	25-1/4	*	39	*	*	*

NOTE:

* Indicates this particular size of actuator has not been used in this type of application. All dimensions shown in inches.

Central Hydraulic System - Vertical Stem, Horizontal Line

Note: All dimensional data is for reference only and subject to change. Depending on the application, specific actuator controls may or may not be located inside of the control box. Where specified, there may be additional pressure vessels or power storage tanks which are not shown.

Figure 18.

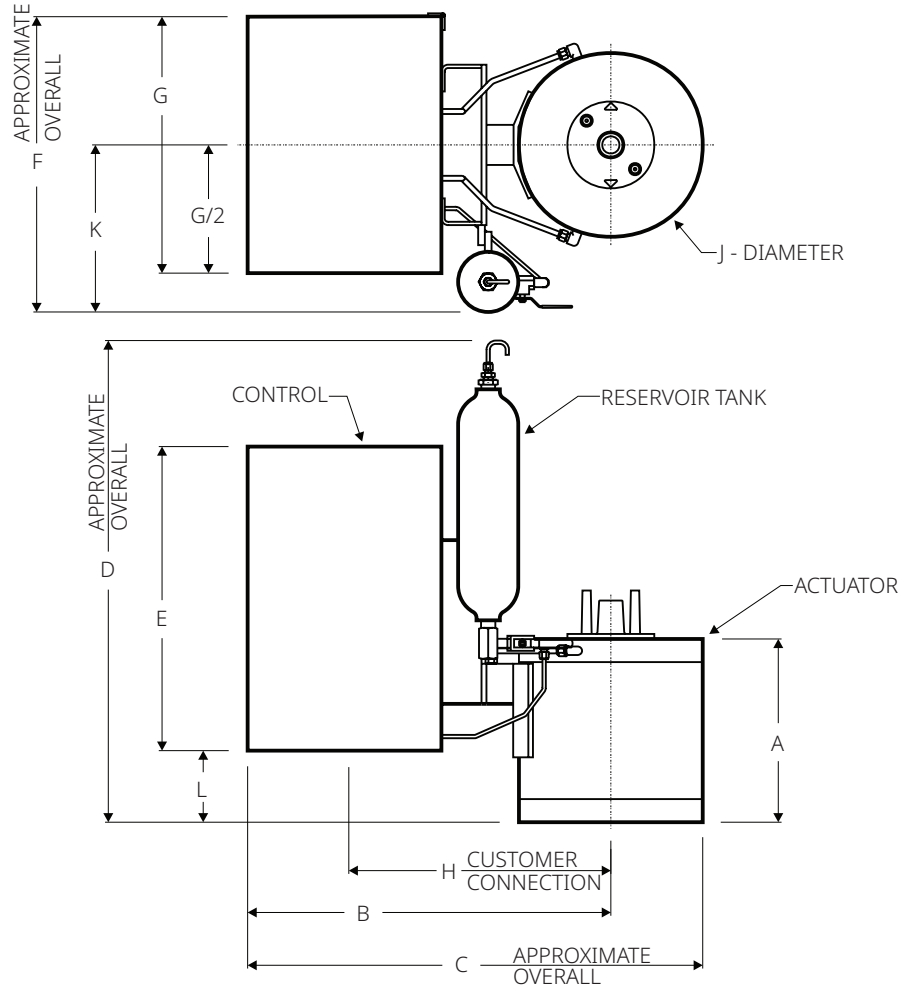

Table 7.

Size	A	B	C	D	E	F	G	H	J	K	L
6-1/2 x 2	5-1/4	24-3/4	29	31-1/4	22-3/4	22	19-1/4	17	8-3/4	12-1/2	1/2
6-1/2 x 3-1/2	6-3/4	24-3/4	29	31-3/4	22-3/4	22	19-1/4	17	8-3/4	12-1/2	1
6-1/2 x 8	11-1/4	24-3/4	29	34-1/2	22-3/4	22	19-1/4	17	8-3/4	12-1/2	3-3/4
9 x 7	10-3/4	26	32	33	22-3/4	22	19-1/4	18-1/2	11-3/4	12-1/2	2-1/2
9 x 12	16-1/4	26	32	38-1/2	22-3/4	22	19-1/4	18-1/2	11-3/4	12-1/2	8
12-1/2 x 8	12-1/2	27-1/4	34	34-1/2	22-3/4	22	19-1/4	19-1/2	15-3/4	12-1/2	1-1/2
12-1/2 x 12	17	28-1/4	36	38-1/2	22-3/4	22	19-1/4	20-3/4	15-3/4	12-1/2	7-3/4
14-1/2 x 16	20-9/16	34-1/4	43-1/4	40-1/2	32-1/2	26-1/2	28-1/4	23-1/4	18-1/4	12-1/2	4
16-1/2 x 16	22-1/2	35	45	41	32-1/2	26-1/2	28-1/4	24	19-3/4	12-1/2	6-1/2
20 x 16	23-1/4	37-1/2	49-3/4	40-3/4	32-1/2	26-1/2	28-1/4	26-1/2	24-1/4	12-1/2	6
25 x 16	24-1/2	36-3/4	51-3/4	50-3/4	36-1/2	25	25-1/4	28-1/2	30	12-1/2	14-1/4
26 x 22	32	37-1/4	52-3/4	53-1/4	36-1/2	25	25-1/4	28-3/4	31	12-1/2	16-3/4
26 x 36	45-1/4	*	*	*	36-1/2	*	25-1/4	*	31	*	*
33 x 32	41-1/4	*	*	*	36-1/2	*	25-1/4	*	39	*	*

NOTE:

* Indicates this particular size of actuator has not been used in this type of application. All dimensions shown in inches.

www.emerson.com/shafer

VCPDS-15619-US © 2024 Emerson. All rights reserved.

The Emerson logo is a trademark and service mark of Emerson Electric Co. Shafer™ is a mark of one of the Emerson family of companies. All other marks are property of their respective owners.

The contents of this publication are presented for informational purposes only, and while every effort has been made to ensure their accuracy, they are not to be construed as warranties or guarantees, express or implied, regarding the products or services described herein or their use or applicability. All sales are governed by our terms and conditions, which are available upon request. We reserve the right to modify or improve the designs or specifications of such products at any time without notice.

SHAFER™

