

Rotary modules RM

RM 12 & RM 32

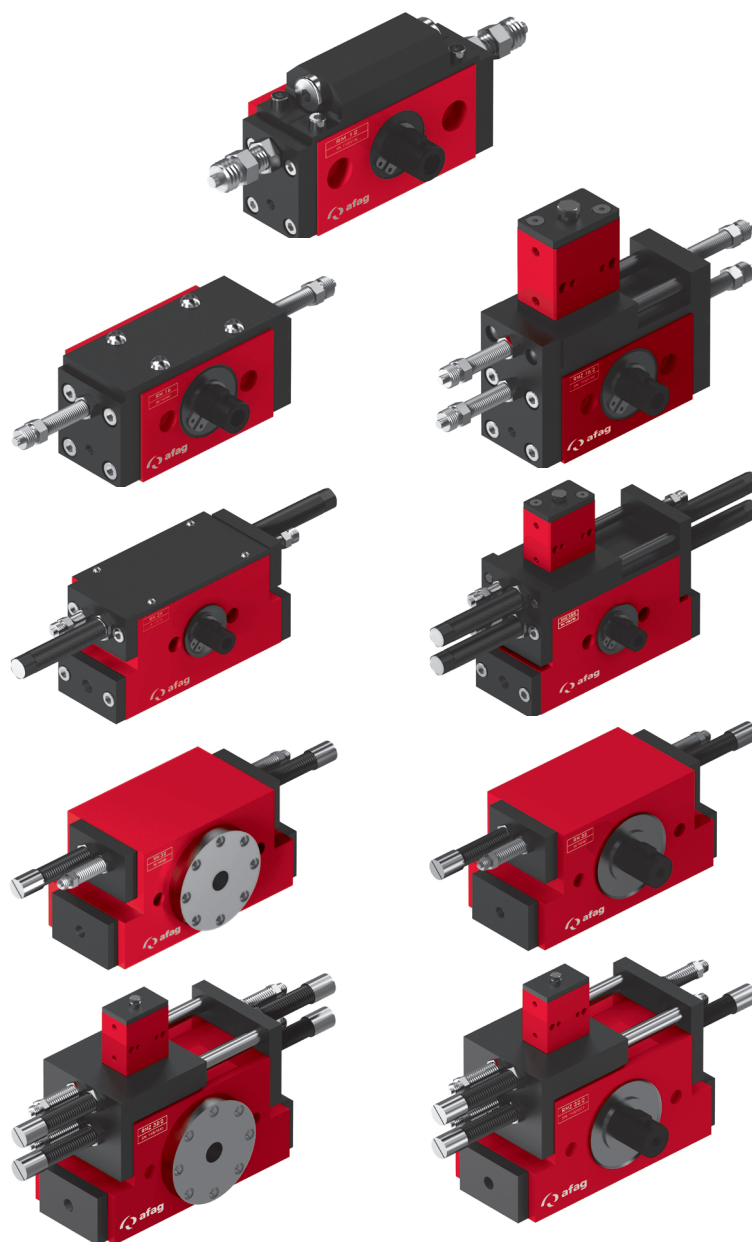
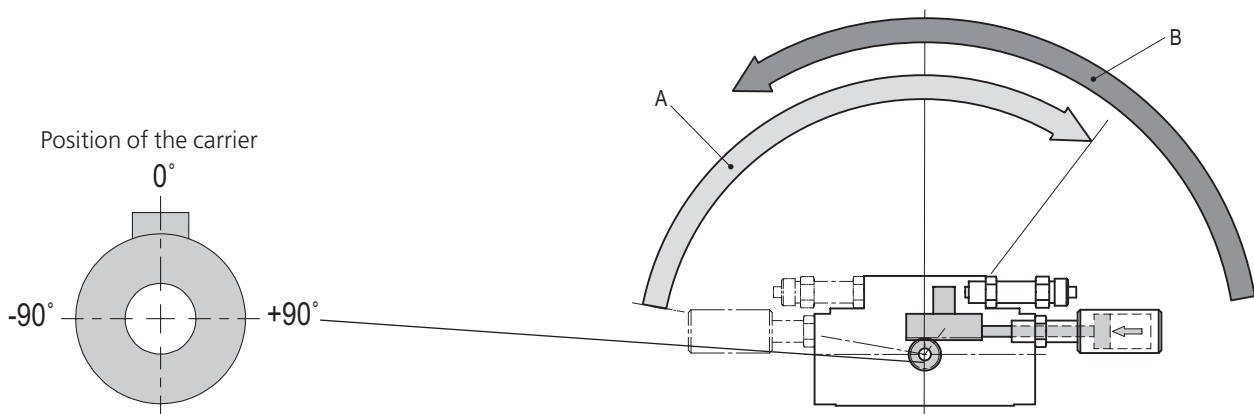

Table of contents: RM

Rotary modules RM	Seite
RM 12	55
RM 16	61
RM 25	71
RM 32	77
Accessories RM	86

Legend	
A	Setting range intermediate position, counterclockwise rotation
B	Setting range intermediate position, clockwise rotation



Type	RMZ 12	RMZ 16	RMZ 16/360°
Positions	2	2	2
A	10° - 105°	10° - 95°	10° - 95°
B	170° - 75°	170° - 85°	350° - 265°

Note: Intermediate position A must be on the right side of intermediate position B.

Legend	
A	Setting range cylinder pin, clockwise rotation
B	Setting range intermediate position, clockwise rotation
C	Setting range cylinder pin, counterclockwise rotation
D	Setting range intermediate position, counterclockwise rotation

Intermediate position damped and acknowledged
 RMZ 16/2 is not damped

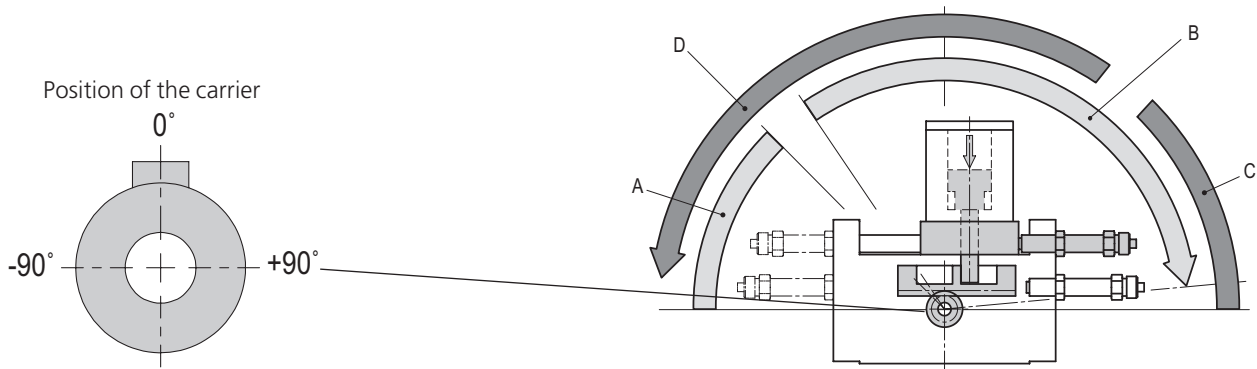

Typ	RMZ 16/2	RMZ 25/1	RMZ 25/2	RMZ 32/1	RMZ 32/2	RMZ63/1	RMZ 63/2
Positions	2	1	2	1	2	1	2
A	0° - 30°	0° - 30°	0° - 30°	0° - 30°	0° - 30°	0° - 30°	0° - 30°
B	45° - 170°	40° - 160°	44° - 160°	45° - 160°	45° - 160°	65° - 115°	65° - 115°
C	180° - 150°		180° - 150°		180° - 150°		180° - 150°
D	135° - 10°		140° - 20°		135° - 20°		115° - 65°

Note: Intermediate position B must be on the right side of intermediate position D.

Rotary modules RM

RM 12

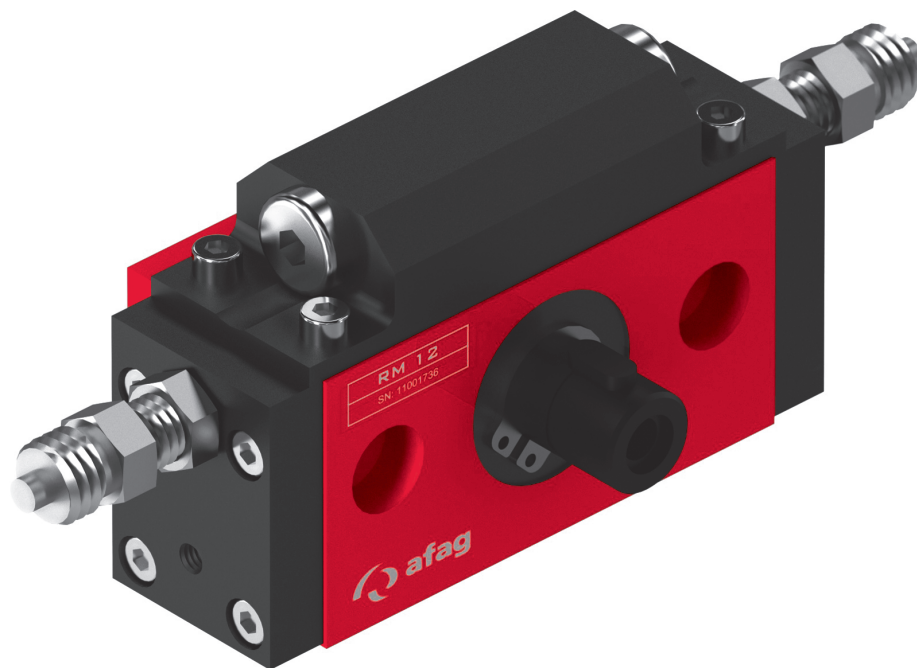

- Very robust
- Intermediate positions optional
- Stepless adjustable rotation angle

Dimensions and dimension drawings

RM 12

Type	RM 12	RM 12-SD	RMZ 12
P	M5	M5	M5

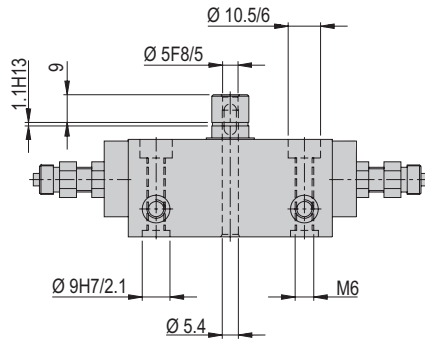

Position of the carrier

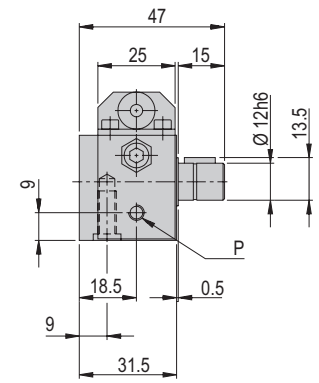
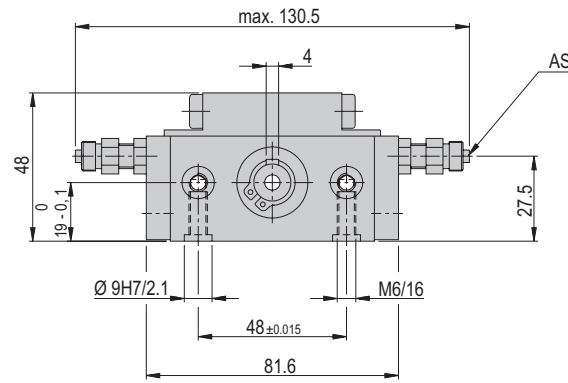
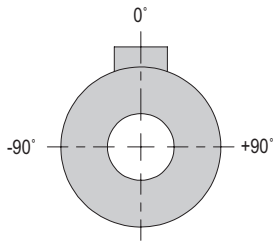

RM 12

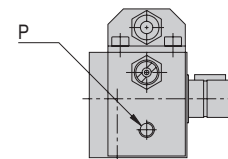
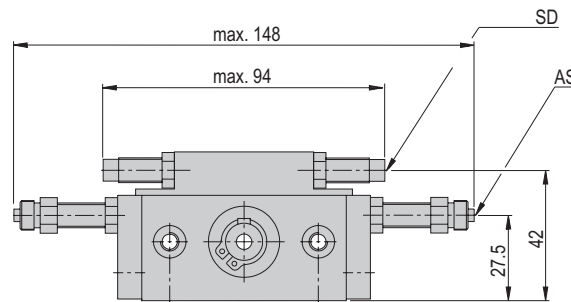

RM 12- SD with shock absorber

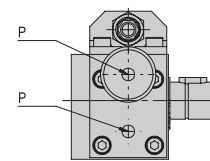
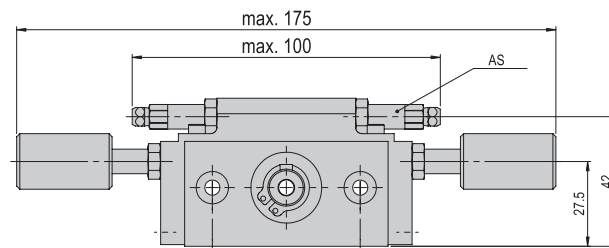

RMZ 12 with 2 cylinders intermediate position (not monitored)



RM 12	
Attachment grid	48 mm
Attachment thread	M6
Operating pressure	6 +/- 2 bar
Air connection P	M5
Operating temperature	0 - 50 °C
Storage temperature	0 - 50 °C
Humidity	< 90 %
Medium filtered compressed air	10 - 40 µm

Type	RM 12	RM 12-SD	RMZ 12
Order number	11001736	11001739	11001737
Net weight	0.323 kg	0.32 kg	0.345 kg
Max. payload, radial	*350 N	*350 N	*350 N
Max. payload, axial	*220 N	*220 N	*220 N
Air consumption (180°)	0.013 NL	0.013 NL	0.021 NL
Angle of rotation	0-180 °	0-180 °	0-180 °
Min. rotation time 90°	0.11 s	0.11 s	0.11 s
Min. rotation time 180°	0.18 s	0.18 s	0.18 s
Noise level	54 dB (A)	54 dB (A)	54 dB (A)
Angle accuracy	0.13 °	0.13 °	0.13 °
Torque	0.3 Nm	0.3 Nm	0.3 Nm
Positions	2	2	4
Mounting position	↕	↕	↕

The technical data refer to a nominal pressure of 6 bar under Afag standard test conditions.

Note: RM 12 is supplied without shock absorbers, RM 12-SD with shock absorbers, RMZ 12 is supplied without shock absorbers and uses ASC 8/30 instead of AS 8/25

The module can be operated with lubricated or dry air.

Cleanroom class ISO 14644-1, class ISO 7

*Observe rotation time diagram

Included in the delivery

(Catalogue HT accessories)

- 2x Centering bushing Ø9x4
- 2x Stop screw AS 08/25
- 1x Key 4x4x10

Accessories

- Rotation flange RM 12 [p. 86]
 - Cylinder, intermediate pos. RMZ 12 [p. 86]
- (Catalogue HT accessories)
- INI d6.5x44-Sn1.5-PNP-NO-M8x1

Alternative accessories

(Catalogue HT accessories)

- INI 8x8x38.5-Sn1.5-PNP-NO-M8x1

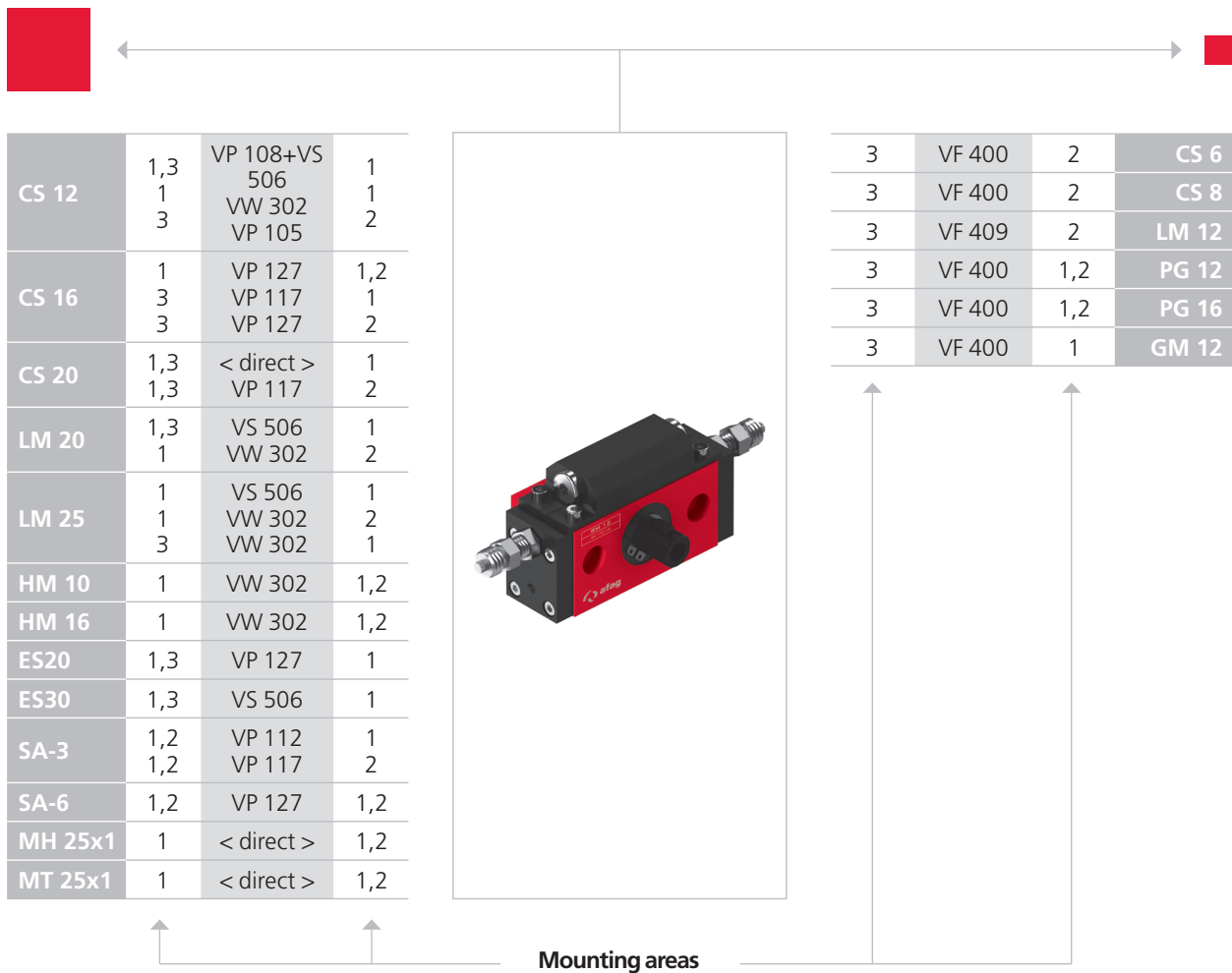

CS, ES	LM	HM	SA	UG, GM, SG, DG, PG, GE, SGE
PMP, PMP-c	PEZ, PDZ	PEL, PDL	RM, RE	CR, RM 32, RE, SREH, RA

Note that there might be different mounting positions from one module to another one.
The required connection elements and the range of support columns are depicted in the catalogue HT accessories.

Rotation time diagrams

Rotation time

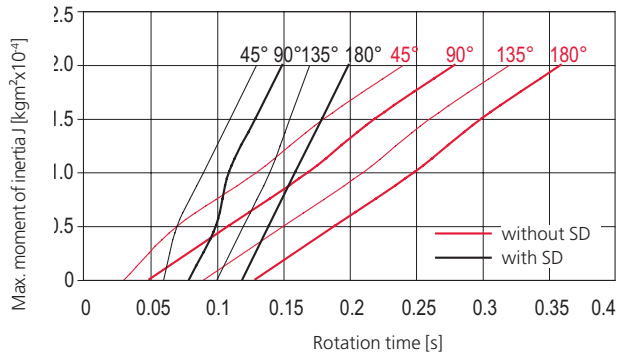

Rotary modules RM

RM 16



- Very robust
- Intermediate positions optional
- Stepless adjustable rotation angle

Dimensions and dimension drawings

RM 16

Type	RM 16	RM 16-SD
P	M5	M5

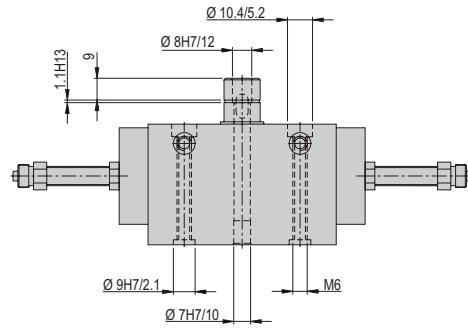

Position of the carrier

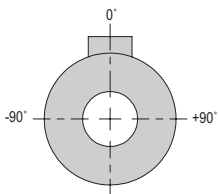

RM 16

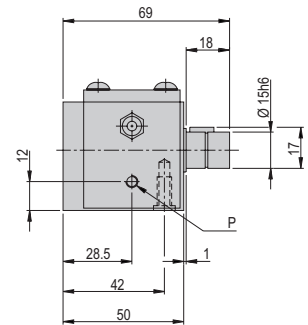
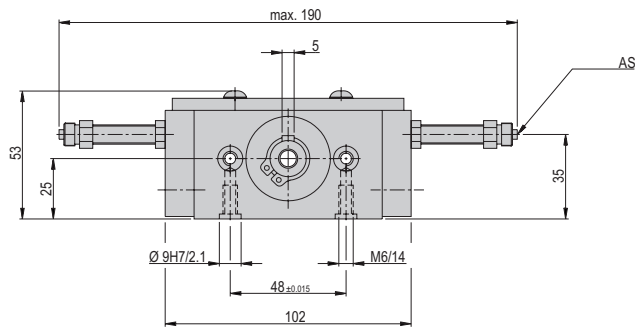

RM 16-SD with shock absorber

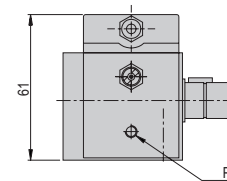
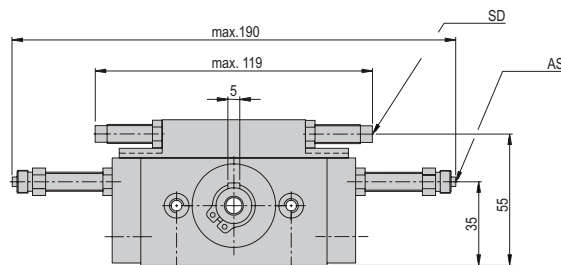



RM 16	
Attachment grid	48 mm
Attachment thread	M6
Operating pressure	6 +/- 2 bar
Air connection P	M5
Operating temperature	0 - 50 °C
Storage temperature	0 - 50 °C
Humidity	< 90 %
Medium filtered compressed air	10 - 40 µm

Type	RM 16	RM 16-SD
Order number	11001697	11001702
Net weight	0.76 kg	0.844 kg
Max. payload, radial	*1200 N	*1200 N
Max. payload, axial	*800 N	*800 N
Air consumption (180°)	0.27 NL	0.27 NL
Angle of rotation	0-180 °	0-180 °
Min. rotation time 90°	0.16 s	0.16 s
Min. rotation time 180°	0.3 s	0.3 s
Noise level	58 dB (A)	58 dB (A)
Angle accuracy	0.1 °	0.1 °
Torque	0.6 Nm	0.6 Nm
Positions	2	2
Mounting position	↕	↕

The technical data refer to a nominal pressure of 6 bar under Afag standard test conditions.
 Note: Rm 16 is supplied without shock absorbers, RM 16-SD is supplied with shock absorbers.
 The module can be operated with lubricated or dry air.
 Cleanroom class ISO 14644-1, class ISO 7

*Observe rotation time diagram

- Included in the delivery**
 (Catalogue HT accessories)
- 2x Centering bushing Ø9x4
 - 2x Stop screw AS 08/40
 - 1x Key 5x5x10
 - 2x Shock absorber SD M8x1 -3

- Accessories**
- Torque amplifier RM 16 [p. 87]
 - Cylinder, intermediate position RM 16 [p. 87]
 - Accessories intermediate pos. RM 16 [p. 88]
 - Accessories shock absorber RM 16 [p. 88]
 - Clamping support RM 16/RM 25 [p. 89]
- (Catalogue HT accessories)
- INI d6.5x44-Sn1.5-PNP-NO-M8x1

- Alternative accessories**
 (Catalogue HT accessories)
- INI 8x8xx38.5-Sn1.5-PNP-NO-M8x1

Dimensions and dimension drawings

RM 16/360°

Type	RM 16-SD/360°	RMZ 16/360°
P	M5	M5

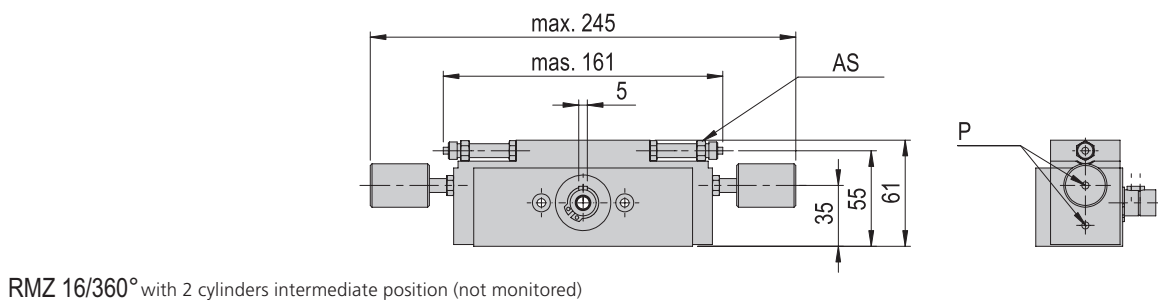
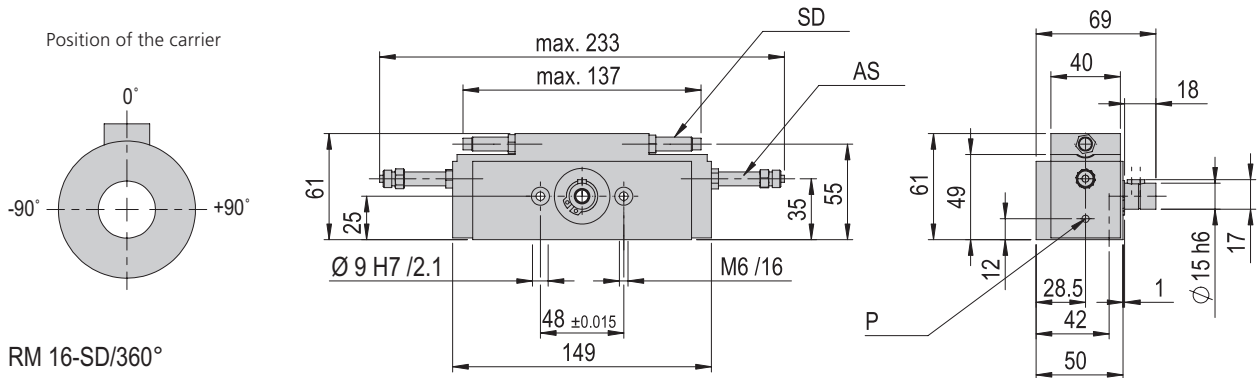



RM 16/360°	
Attachment grid	48 mm
Attachment thread	M6
Operating pressure	6 +/- 2 bar
Air connection P	M5
Operating temperature	0 - 50 °C
Storage temperature	0 - 50 °C
Humidity	< 90 %
Medium filtered compressed air	10 - 40 µm

Type	RM 16-SD/360°	RMZ 16/360°
Order number	11009028	11009029
Net weight	1.162 kg	1.247 kg
Max. payload, radial	*1200 N	*1200 N
Max. payload, axial	*800 N	*800 N
Air consumption (180°)	0.055 NL	0.071 NL
Angle of rotation	0-360 °	0-360 °
Min. rotation time 90°	0.16 s	0.16 s
Min. rotation time 180°	0.3 s	0.3 s
Noise level	58 dB (A)	58 dB (A)
Angle accuracy	0.1 °	0.1 °
Torque	0.6 Nm	0.6 Nm
Positions	2	4
Mounting position	↕	↔

The technical data refer to a nominal pressure of 6 bar under Afag standard test conditions.
 Note: Rm 16 is supplied without shock absorbers, RM 16-SD is supplied with shock absorbers.
 The module can be operated with lubricated or dry air.
 Cleanroom class ISO 14644-1, class ISO 7

*Observe rotation time diagram

Included in the delivery (Catalogue HT accessories)

- 2x Centering bushing Ø9x4
- 2x Stop screw AS 08/40
- 1x Key 5x5x10
- 2x Shock absorber SD M8x1 -3
- 2x Cylinder, intermediate position RMZ 16/360°

Accessories

- Clamping support RM 16/RM 25 [p. 89]
(Catalogue HT accessories)
- INI d6.5x44-Sn1.5-PNP-NO-M8x1

Alternative accessories

- (Catalogue HT accessories)
- INI 8x8x38.5-Sn1.5-PNP-NO-M8x1

Dimensions and dimension drawings

RMZ 16

Type	RMZ 16	RMZ 16/2
P	M5	M5

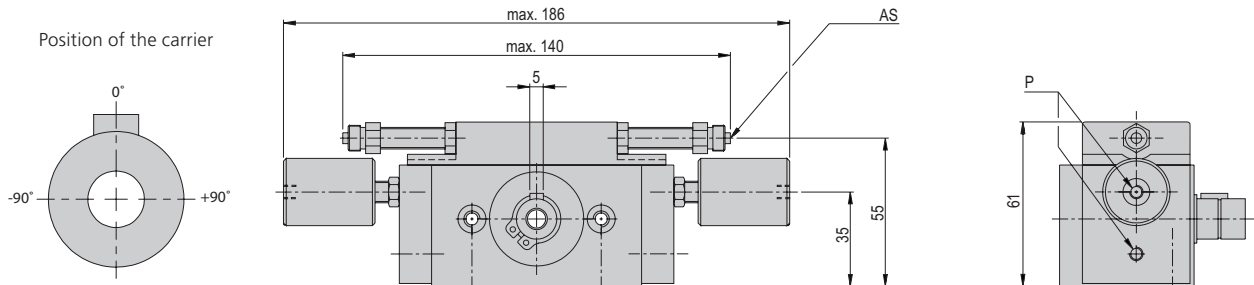

RMZ 16 with 2 cylinders intermediate position (not monitored)

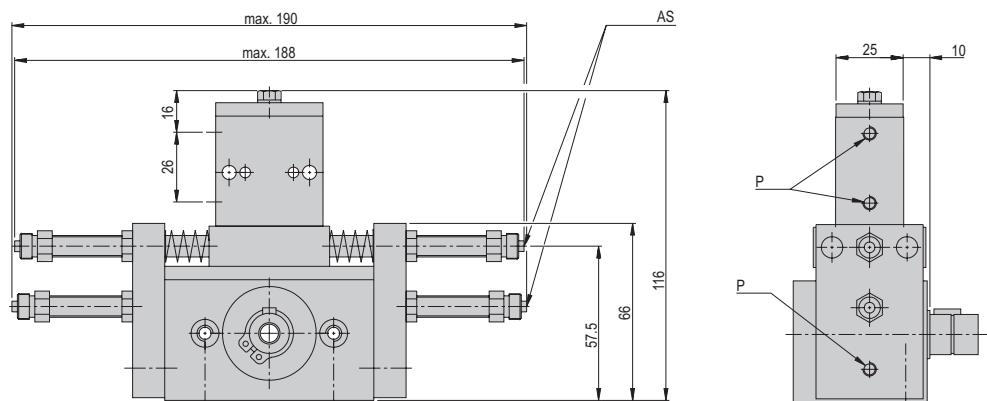

RMZ 16/2 with 2 cylinders intermediate position (monitored)

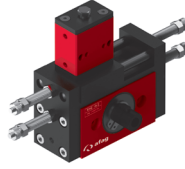

RMZ 16	
Attachment grid	48 mm
Attachment thread	M6
Operating pressure	6 +/- 2 bar
Air connection P	M5
Operating temperature	0 - 50 °C
Storage temperature	0 - 50 °C
Humidity	< 90 %
Medium filtered compressed air	10 - 40 µm

Type	RMZ 16	RMZ 16/2
Order number	11001699	11001700
Net weight	0.913 kg	1.21 kg
Max. payload, radial	*1200 N	*1200 N
Max. payload, axial	*800 N	*800 N
Air consumption (180°)	0.048 NL	0.048 NL
Angle of rotation	0-180 °	0-180 °
Min. rotation time 90°	0.16 s	0.16 s
Min. rotation time 180°	0.3 s	0.3 s
Noise level	58 dB (A)	58 dB (A)
Angle accuracy	0.1 °	0.1 °
Torque	0.6 Nm	0.6 Nm
Positions	4	4
Mounting position	↔	↔

The technical data refer to a nominal pressure of 6 bar under Afag standard test conditions.
 Note: Rm 16 is supplied without shock absorbers, RM 16-SD is supplied with shock absorbers.
 The module can be operated with lubricated or dry air.
 Cleanroom class ISO 14644-1, class ISO 7

*Observe rotation time diagram

Included in the delivery

(Catalogue HT accessories)

- 2x Centering bushing Ø9x4
- 2x Stop screw AS 08/40
- 1x Key 5x5x10
- 2x Shock absorber SD M8x1 -3

Accessories

- Torque amplifier RM 16 [p. 87]
- Cylinder, intermediate position RM 16 [p. 87]
- Cylinder, intermediate position RMZ 16/360° [p. 87]
- Accessories intermediate position RM 16 [p. 88]
- Accessories shock absorber RM 16 [p. 88]
- Clamping support RM 16/RM 25 [p. 89]

(Catalogue HT accessories)

- INI d6.5x44-Sn1.5-PNP-NO-M8x1

Alternative accessories

(Catalogue HT accessories)

- INI 8x8x38.5-Sn1.5-PNP-NO-M8x1

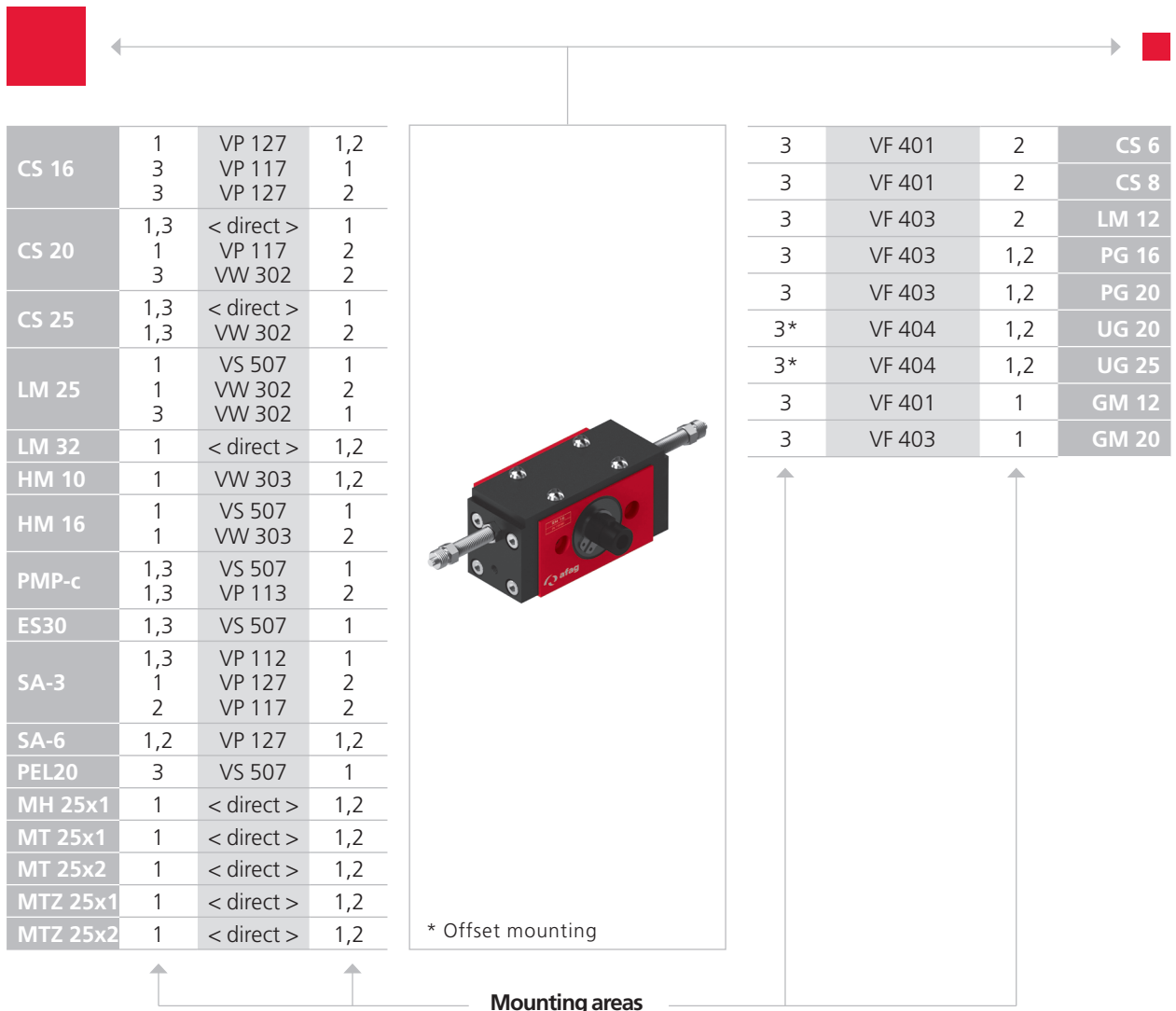

CS, ES	LM	HM	SA	UG, GM, SG, DG, PG, GE, SGE
PMP, PMP-c	PEZ, PDZ	PEL, PDL	RM, RE	CR, RM 32, RE, SREH, RA

Note that there might be different mounting positions from one module to another one.
The required connection elements and the range of support columns are depicted in the catalogue HT accessories.

Rotation time diagrams

Rotation time

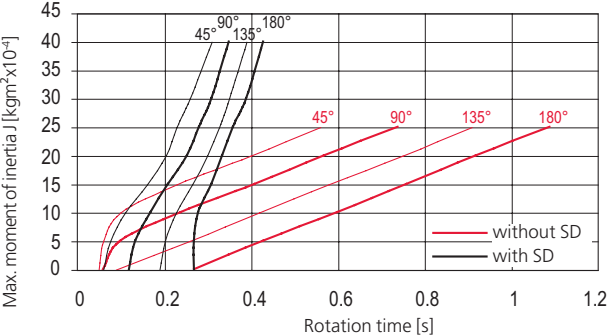

Rotary modules RM

RM 25

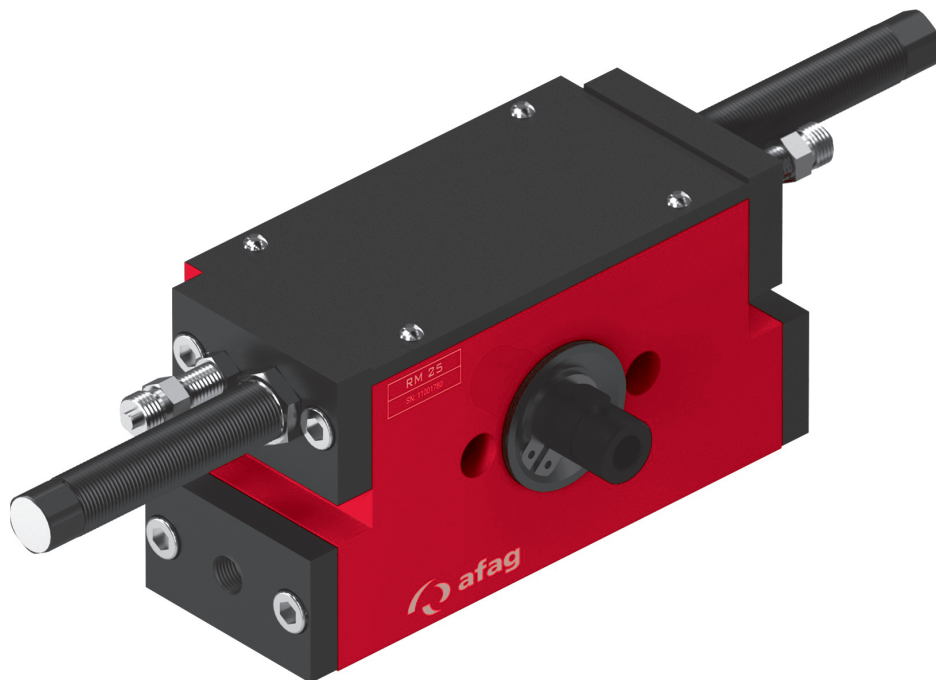

- Very robust
- Intermediate positions optional
- Stepless adjustable rotation angle

Dimensions and dimension drawings

RM 25

Type	RM 25	RMZ 25/1	RMZ 25/2
P	G 1/8 "		
P1		M5	M5
P2		G 1/8 "	G 1/8 "

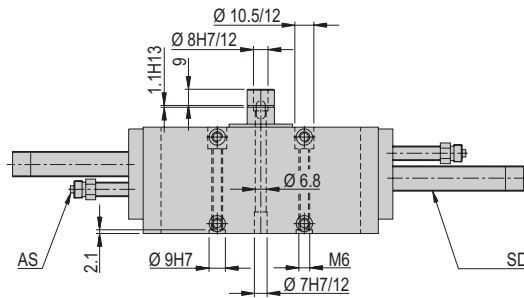

Position of the carrier

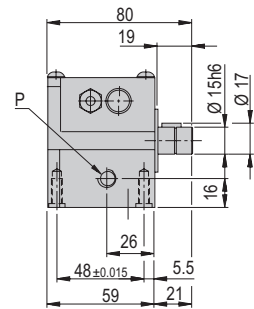
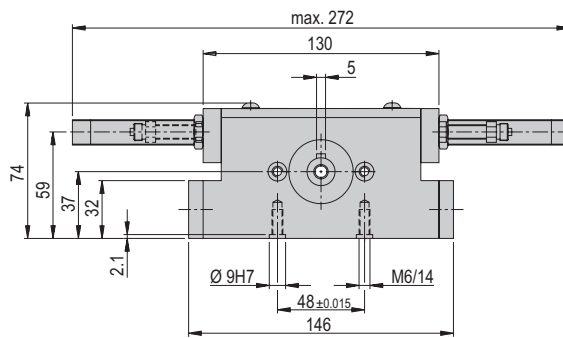
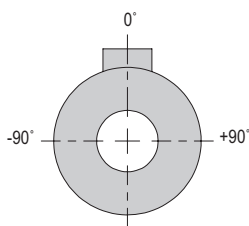

RM 25

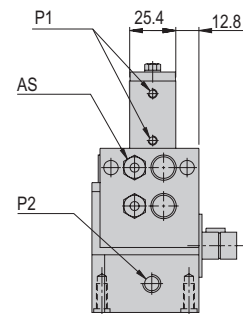
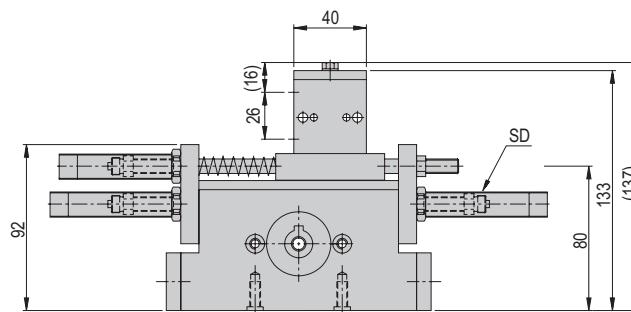

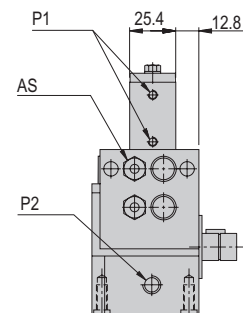
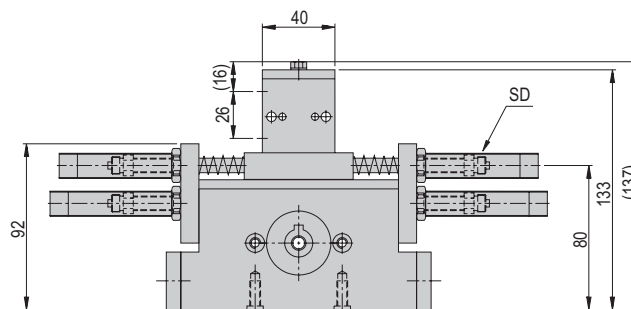

RMZ 25/1 with 1 intermediate position (monitored)

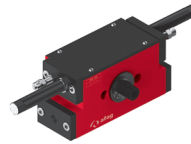

RMZ 25/2 with 2 intermediate position (monitored)



RM 25	
Attachment grid	48 x 48 mm
Attachment thread	M6
Operating pressure	6 +/- 2 bar
Air connection P	M5 / G 1/8 "
Operating temperature	0 - 50 °C
Storage temperature	0 - 50 °C
Humidity	< 90 %
Medium filtered compressed air	10 - 40 µm

Type	RM 25	RMZ 25/1	RMZ 25/2
Order number	11001780	11001781	11001782
Net weight	2 kg	2.686 kg	2.7 kg
Max. payload, radial	*1400 N	*1400 N	*1400 N
Max. payload, axial	*800 N	*800 N	*800 N
Air consumption (180°)	0.12 NL	0.14 NL	0.14 NL
Angle of rotation	0-180 °	0-180 °	0-180 °
Min. rotation time 90°	0.5 s	0.5 s	0.5 s
Min. rotation time 180°	0.7 s	0.7 s	0.7 s
Noise level	60 dB (A)	60 dB (A)	60 dB (A)
Angle accuracy	0.083 °	0.083 °	0.083 °
Torque	2.5 Nm	2.5 Nm	2.5 Nm
Positions	2	3	4
Mounting position			

The technical data refer to a nominal pressure of 6 bar under Afag standard test conditions.
 The module can be operated with lubricated or dry air.
 Cleanroom class ISO 14644-1, class ISO 7

*Observe rotation time diagram

Included in the delivery (Catalogue HT accessories)

- 2x Centering bushing Ø9x4
- 1x Key 5x5x10
- 2x Stop screw AS 08/40
- 2x Shock absorber SD M14x1 -1

Accessories

- Cylinder, intermediate pos. RM 25/x [p. 87]
 - Clamping support RM 16/RM 25 [p. 89]
- (Catalogue HT accessories)
- INI d6.5x44-Sn1.5-PNP-NO-M8x1

Alternative accessories (Catalogue HT accessories)

- INI 8x8xx38.5-Sn1.5-PNP-NO-M8x1

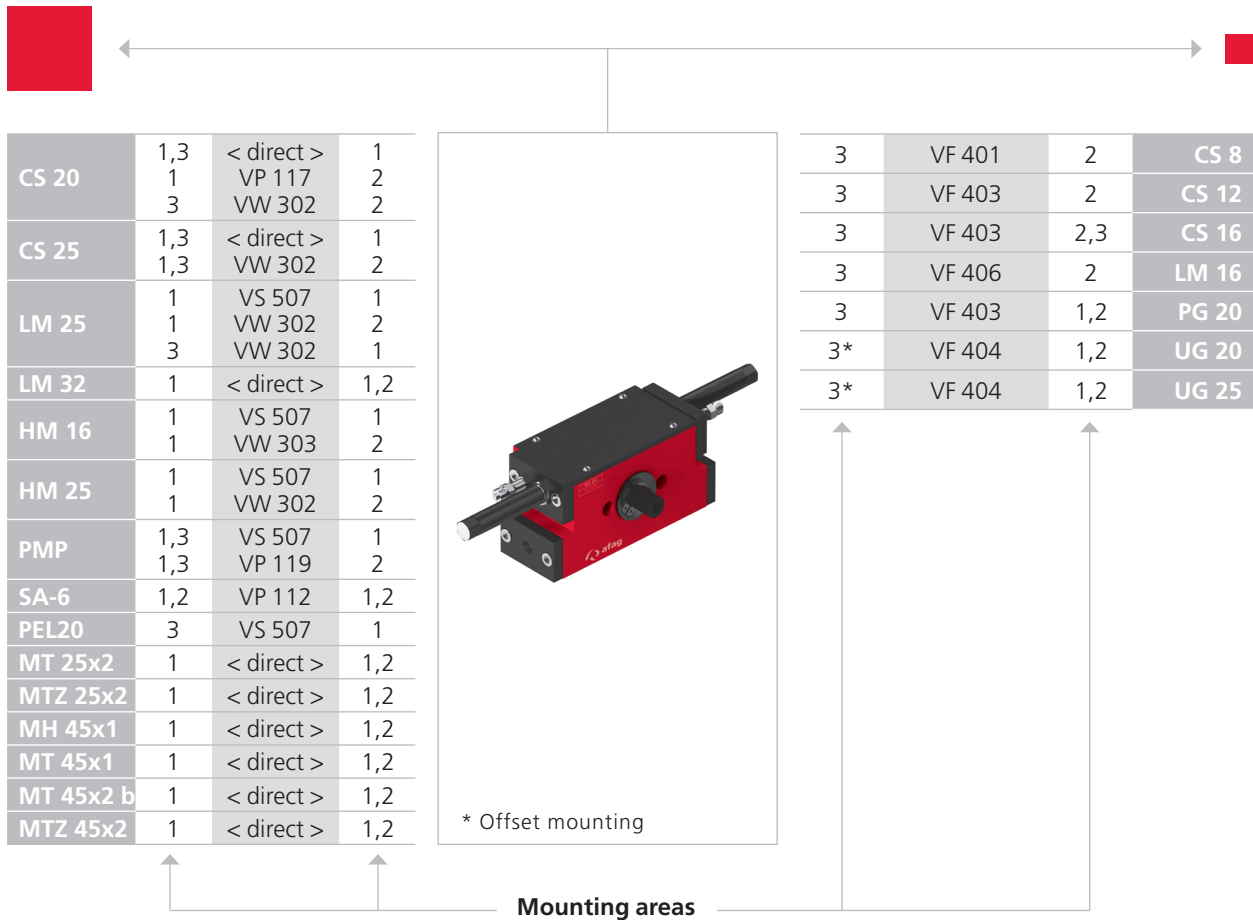

CS, ES 	LM 	HM 	SA 	UG, GM, SG, DG, PG, GE, SGE
PMP, PMP-c 	PEZ, PDZ 	PEL, PDL 	RM, RE 	CR, RM 32, RE, SREH, RA

Note that there might be different mounting positions from one module to another one.
The required connection elements and the range of support columns are depicted in the catalogue HT accessories.

Rotation time diagrams

Rotation time

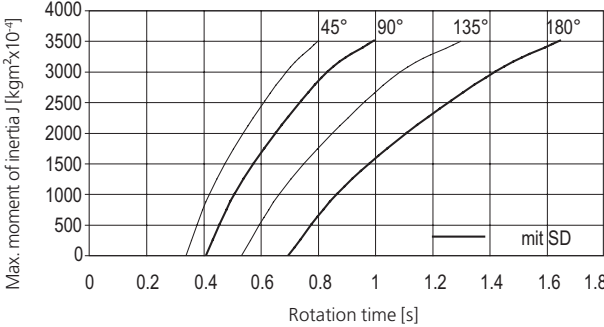

Rotary modules RM

RM 32

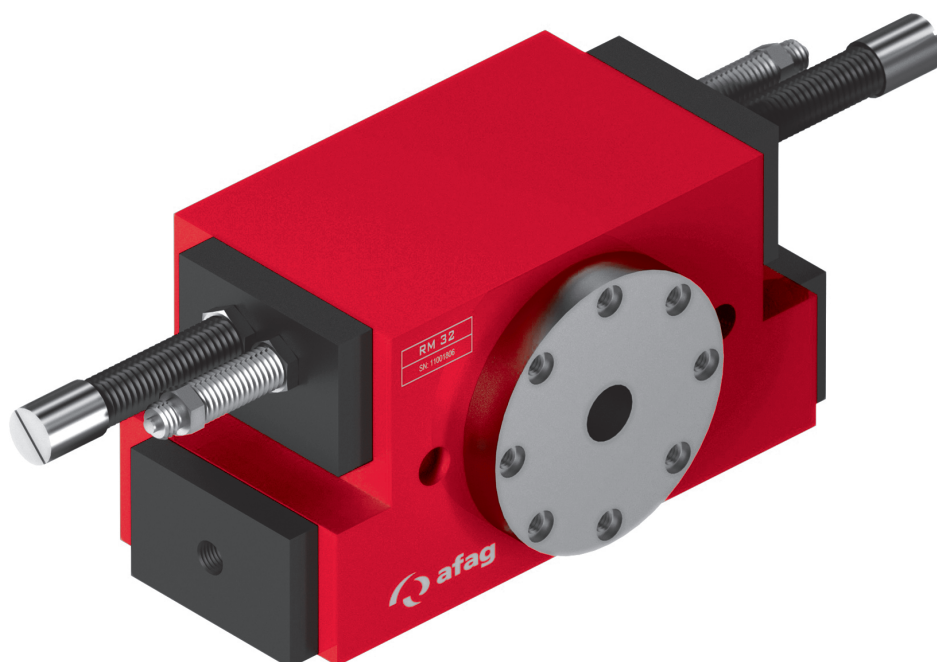

- Very robust
- Intermediate positions optional
- Stepless adjustable rotation angle

Dimensions and dimension drawings

RM 32

Type	RM 32 with flange	RM 32 with shaft
P	G1/8 "	G1/8 "

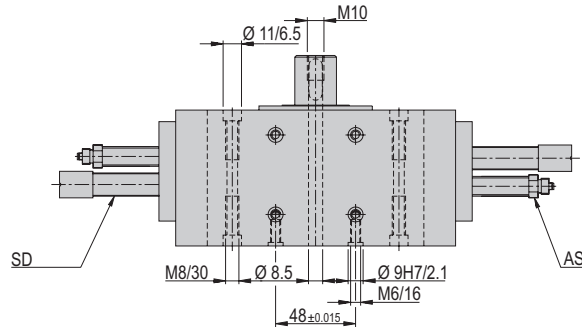

Position of the carrier

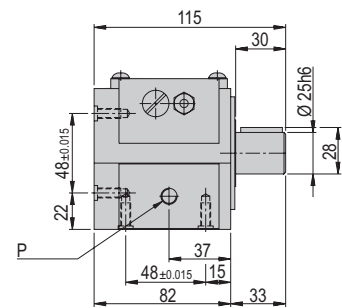
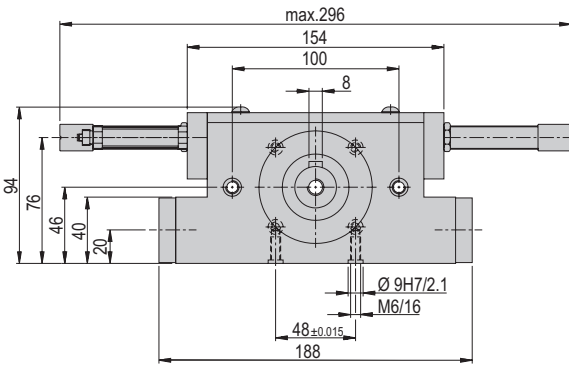
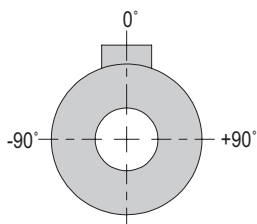

RM 32 with shaft

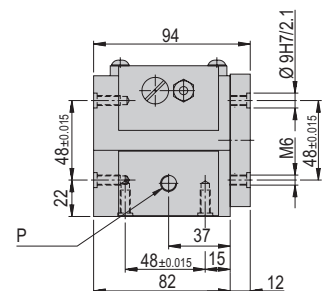
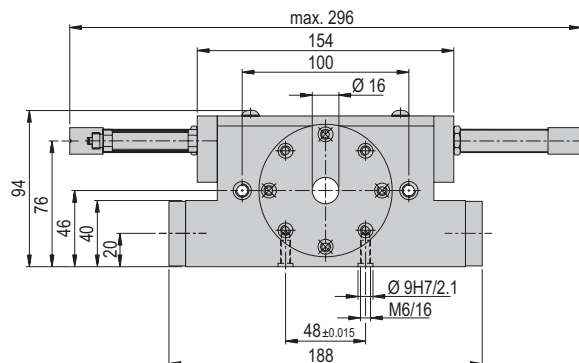
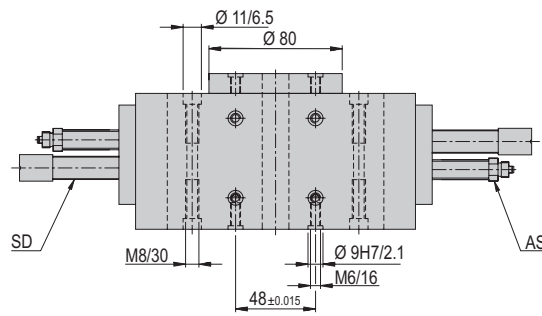

RM 32 with flange

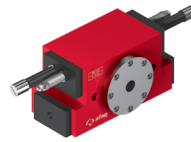

RM 32	
Attachment grid	48 x 48 mm
Attachment thread	M6
Operating pressure	6 +/- 2 bar
Air connection P	G1/8 "
Operating temperature	0 - 50 °C
Storage temperature	0 - 50 °C
Humidity	< 90 %
Medium filtered compressed air	10 - 40 µm

Type	RM 32 with flange	RM 32 with shaft
Order number	11001806	11001807
Net weight	4.82 kg	4.64 kg
Max. payload, radial	*3000 N	*3000 N
Max. payload, axial	*3000 N	*3000 N
Air consumption (180°)	0.25 NL	0.25 NL
Angle of rotation	0-180 °	0-180 °
Min. rotation time 90°	0.21 s	0.21 s
Min. rotation time 180°	0.27 s	0.27 s
Noise level	60 dB (A)	60 dB (A)
Angle accuracy	0.067 °	0.067 °
Torque	6 Nm	6 Nm
Positions	2	2
Mounting position	✚	✚

The technical data refer to a nominal pressure of 6 bar under Afag standard test conditions.
 The module can be operated with lubricated or dry air.
 Cleanroom class ISO 14644-1, class ISO 7

*Observe rotation time diagram

Included in the delivery

- (Catalogue HT accessories)
- 2x Centering bushing Ø9x4
 - 2x Shock absorber SD M14x1 -2
 - 2x Stop screw AS 12/60

Accessories

- Universal adapter UA RM 32 [p. 89] (Catalogue HT accessories)
- INI d6.5x44-Sn1.5-PNP-NO-M8x1

Alternative accessories

- (Catalogue HT accessories)
- INI 8x8xx38.5-Sn1.5-PNP-NO-M8x1

Dimensions and dimension drawings

RMZ 32

Type	RMZ 32/1 with flange	RMZ 32/1 with shaft
P1	M5	M5
P2	G1/8"	G1/8"

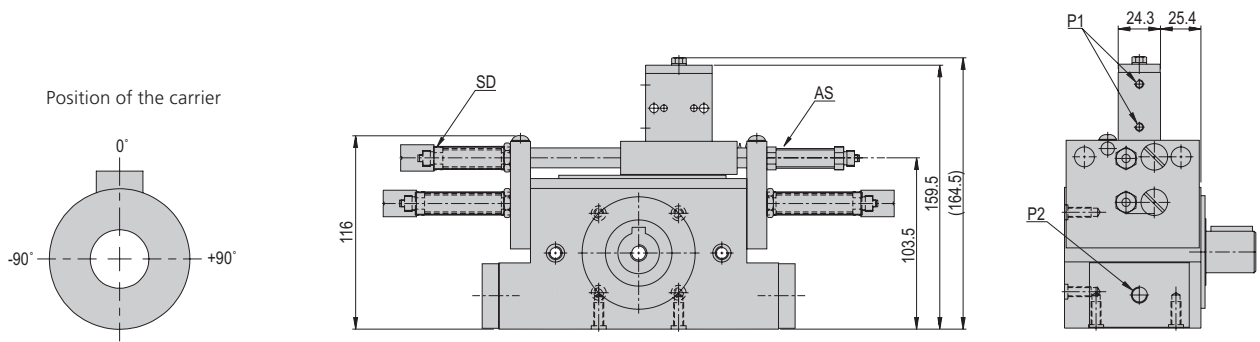

RMZ 32/1 with shaft, 1 intermediate position (monitored)

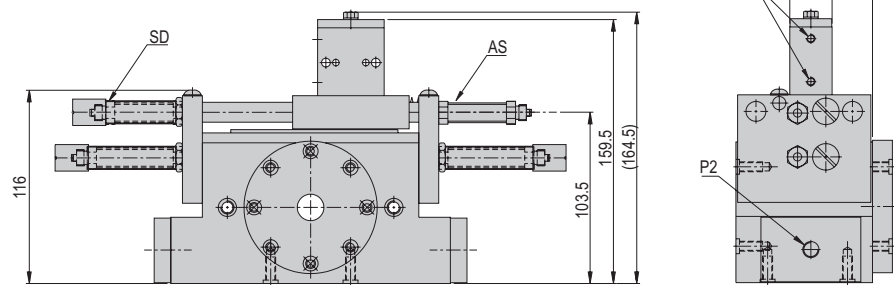

RMZ 32/1 with flange, 2 intermediate positions (monitored)

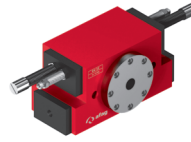

RM 32	
Attachment grid	48 x 48 mm
Attachment thread	M6
Operating pressure	6 +/- 2 bar
Air connection P	M5 / G1/8 "
Operating temperature	0 - 50 °C
Storage temperature	0 - 50 °C
Humidity	< 90 %
Medium filtered compressed air	10 - 40 µm

Type	RMZ 32/1 with flange	RMZ 32/1 with shaft
Order number	11001808	11001809
Net weight	6.361 kg	6.178 kg
Max. payload, radial	*3000 N	*3000 N
Max. payload, axial	*3000 N	*3000 N
Air consumption (180°)	0.27 NL	0.27 NL
Angle of rotation	0-180 °	0-180 °
Min. rotation time 90°	0.21 s	0.21 s
Min. rotation time 180°	0.27 s	0.27 s
Noise level	60 dB (A)	60 dB (A)
Angle accuracy	0.067 °	0.067 °
Torque	6 Nm	6 Nm
Positions	3	3
Mounting position	↔	↔

The technical data refer to a nominal pressure of 6 bar under Afag standard test conditions.
 The module can be operated with lubricated or dry air.
 Cleanroom class ISO 14644-1, class ISO 7

*Observe rotation time diagram

Included in the delivery

- (Catalogue HT accessories)
- 2x Centering bushing Ø9x4
 - 2x Shock absorber SD M14x1 -2
 - 2x Stop screw AS 12/60

Accessories

- Universal adapter UA RM 32 [p. 89]
- (Catalogue HT accessories)
- INI d6.5x44-Sn1.5-PNP-NO-M8x1

Alternative accessories

- (Catalogue HT accessories)
- INI 8x8xx38.5-Sn1.5-PNP-NO-M8x1

Dimensions and dimension drawings

RM 32

Type	RMZ 32/2 with flange	RMZ 32/2 with shaft
P1	M5	M5
P2	G1/8"	G1/8"

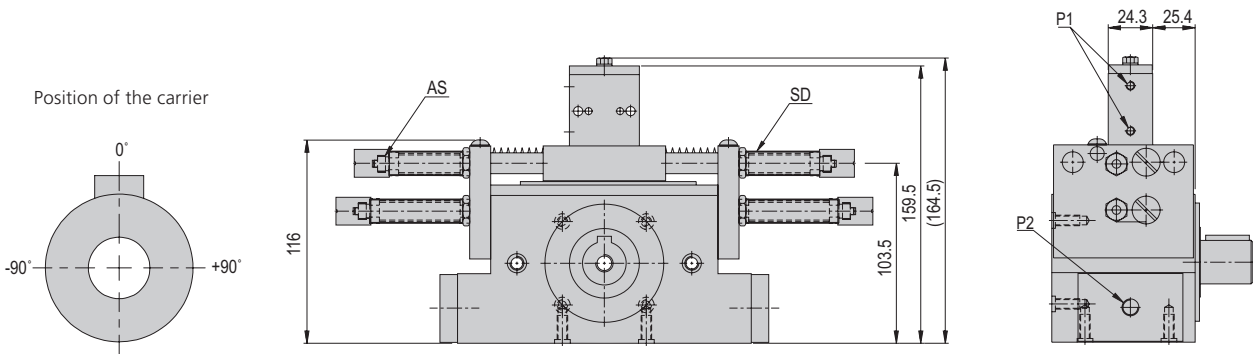

RMZ 32/2 with shaft, 2 intermediate positions (monitored)

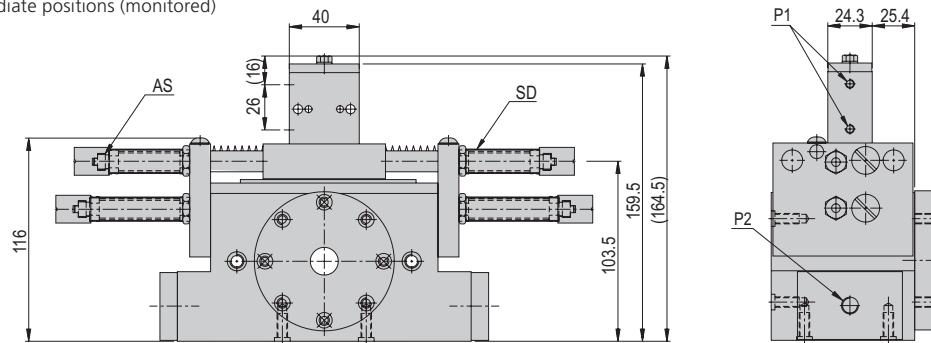

RMZ 32/2 with flange, 2 intermediate positions (monitored)

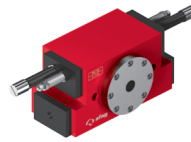

RM 32	
Attachment grid	48 x 48 mm
Attachment thread	M6
Operating pressure	6 +/- 2 bar
Air connection P	M5 / G1/8 "
Operating temperature	0 - 50 °C
Storage temperature	0 - 50 °C
Humidity	< 90 %
Medium filtered compressed air	10 - 40 µm

Type	RMZ 32/2 with flange	RMZ 32/2 with shaft
Order number	11001810	11001811
Net weight	6.45 kg	6.267 kg
Max. payload, radial	*3000 N	*3000 N
Max. payload, axial	*3000 N	*3000 N
Air consumption (180°)	0.27 NL	0.27 NL
Angle of rotation	0-180 °	0-180 °
Min. rotation time 90°	0.21 s	0.21 s
Min. rotation time 180°	0.27 s	0.27 s
Noise level	62 dB (A)	62 dB (A)
Angle accuracy	0.067 °	0.067 °
Torque	6 Nm	6 Nm
Positions	4	4
Mounting position	↔	↔

The technical data refer to a nominal pressure of 6 bar under Afag standard test conditions.
 The module can be operated with lubricated or dry air.
 Cleanroom class ISO 14644-1, class ISO 7

*Observe rotation time diagram

Included in the delivery

- (Catalogue HT accessories)
- 2x Centering bushing Ø9x4
 - 2x Shock absorber SD M14x1 -2
 - 2x Stop screw AS 12/60

Accessories

- (Catalogue HT accessories)
- Universal adapter UA RM 32 [p. 89]
 - INI d6.5x44-Sn1.5-PNP-NO-M8x1

Alternative accessories

- (Catalogue HT accessories)
- INI 8x8xx38.5-Sn1.5-PNP-NO-M8x1

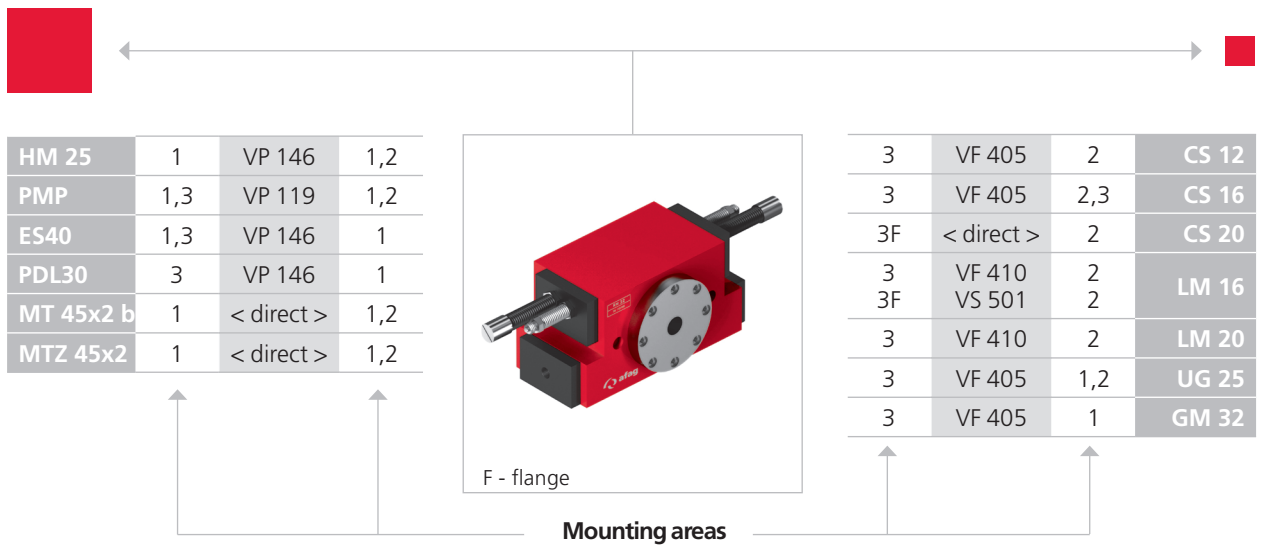

CS, ES	LM	HM	SA	UG, GM, SG, DG, PG, GE, SGE
PMP, PMP-c	PEZ, PDZ	PEL, PDL	RM, RE	CR, RM 32, RE, SREH, RA

Note that there might be different mounting positions from one module to another one.
 The required connection elements and the range of support columns are depicted in the catalogue HT accessories.

Rotation time diagrams

Rotation time

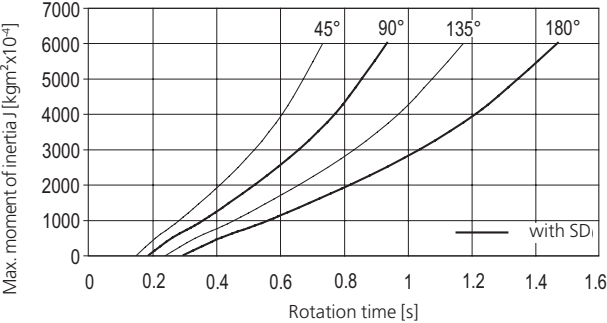

Accessories RM

Rotation flange RM 12	RM 12
Order number	11001824
Net weight	0.033 kg
Suitable for	RM 12 RM 12-SD RMZ 12

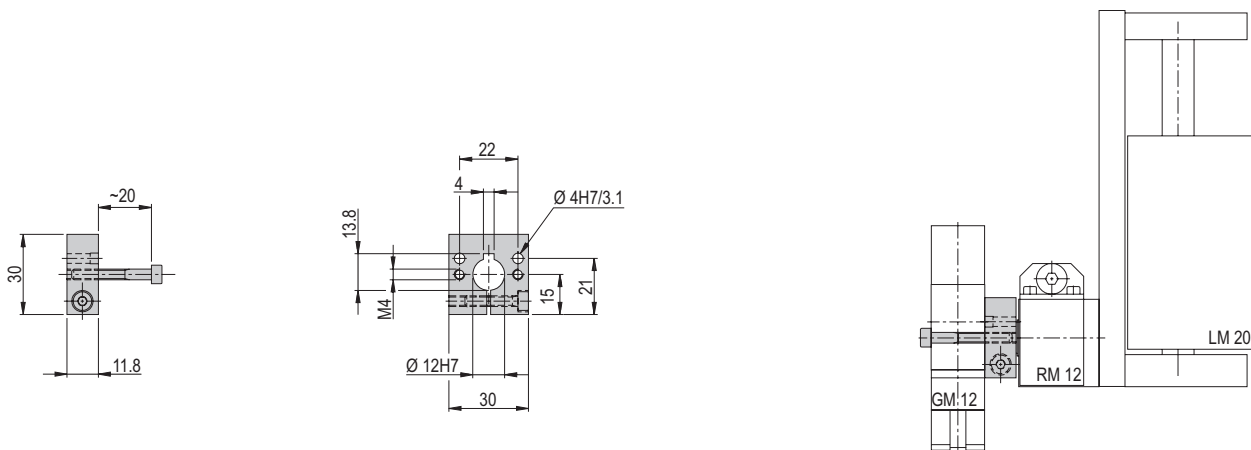

Note: Recommendation for new constructions: Use VF 400.

Cylinder intermediate position RMZ 12	RMZ 12
Order number	11017147
Stroke H	11 mm
Net weight	0.025 kg
Suitable for	RMZ 12
P	M5
SW	10 mm

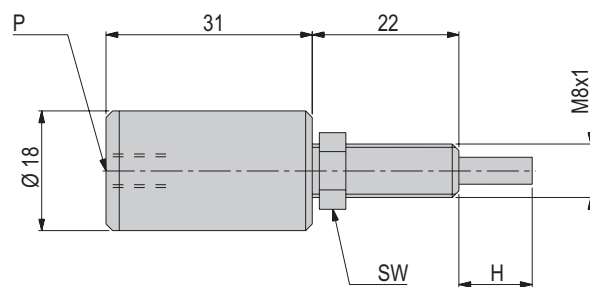

Accessories RM

Torque amplifier RM 16 to increase torque RM 16

Order number	11001676
Net weight	0.39 kg
Torque	1.4 Nm
Suitable for	RM 16 RM 16-SD RMZ 16

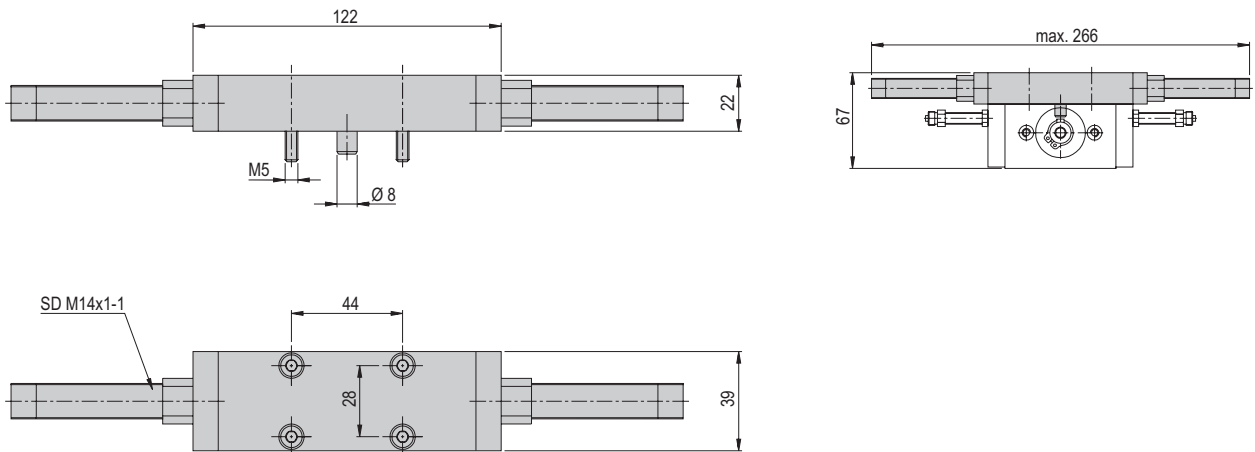

Included in the delivery
(Catalogue HT accessories)
■ 2x Shock absorber SD M14x1 -1

Cylinder, intermediate position RM 16 RMZ 16

Order number	11001670
Stroke H	12 mm
Net weight	0.044 kg
Suitable for	RMZ 16
P	M5
SW	10 mm

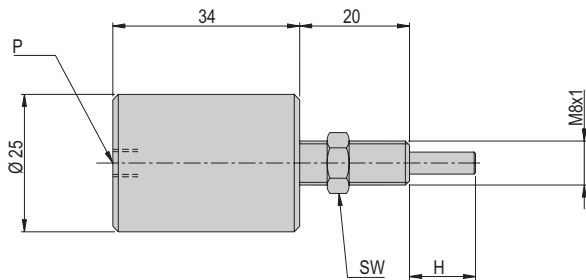

Cylinder intermediate position RMZ 16/360°

Order number	11015776
Stroke H	26,8 mm
Net weight	0.052 kg
Suitable for	RMZ 16/360°
P	M5
SW	10 mm

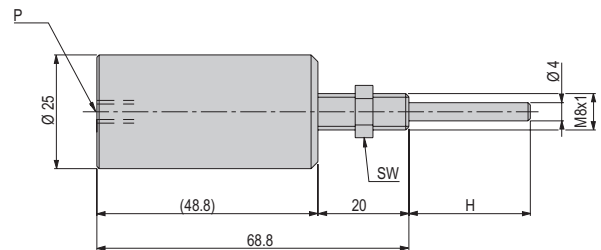

Accessories RM

Accessories intermediate position RM 16		RM 16
Order number		11001680
Stroke H		12 mm
Net weight		0.21 kg
Suitable for		RM 16
P		M5
SW		10 mm

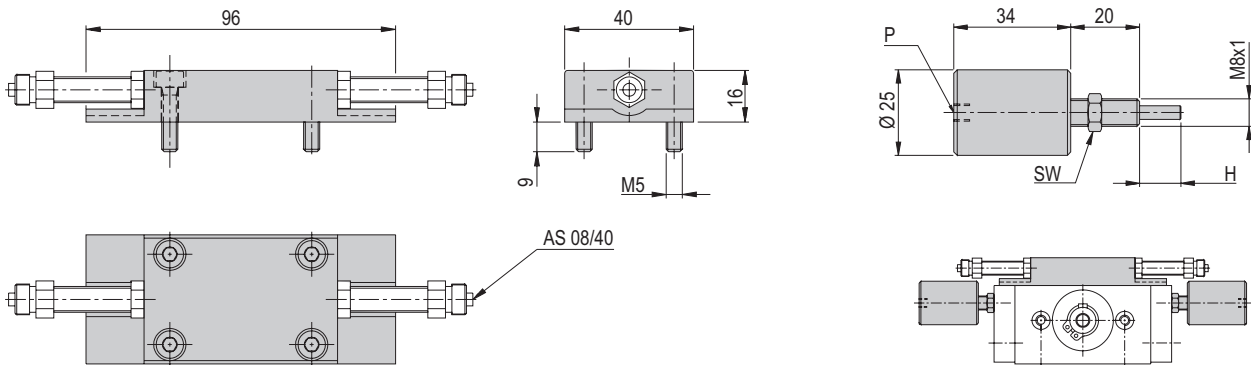

Included in the delivery

(Catalogue HT accessories)

- 2x Cylinder, intermediate position RM 16

Accessories

(Catalogue HT accessories)

- Stop screw AS 08/40

Accessories shock absorber RM 16		RM 16
Order number		11001683
Net weight		0.15 kg
Suitable for		RM 16

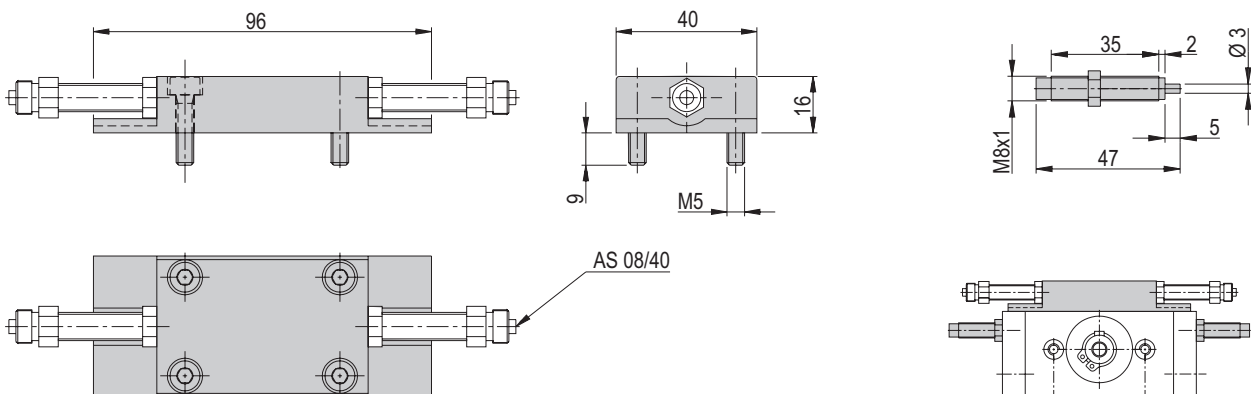

Included in the delivery

(Catalogue HT accessories)

- 2x Shock absorber SD M8x1 -3

Accessories

(Catalogue HT accessories)

- Stop screw AS 08/40

Accessories RM

Clamping support RM 16/RM 25

Order number	11001672
Net weight	0.08 kg
Suitable for	RM 16x RM 25x

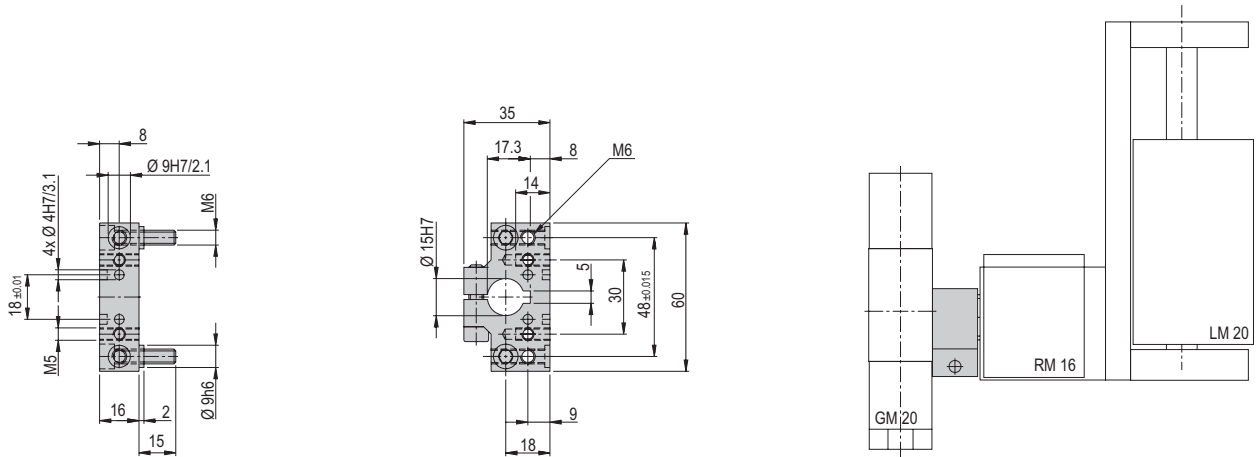

Note: Recommendation for new constructions: Use VF 403.

Universal adapter UA RM 32 **UA RM 32**

Order number	50077150
Net weight	0.126 kg

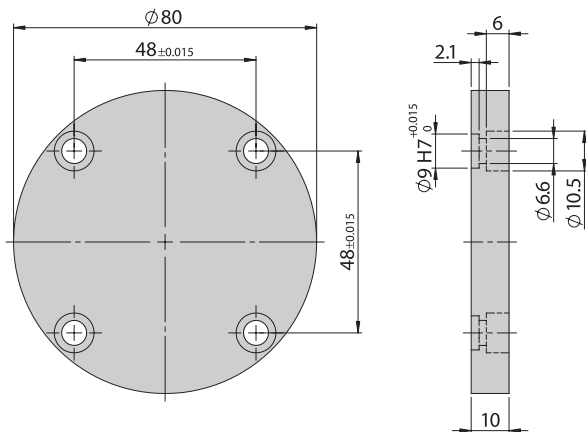

- Included in the delivery**
(Catalogue HT accessories)
- 2x Centering bushing Ø9x4
 - 4x Mounting screw M6x16

	A	B	C	D	E	F	G	H	I	K
RM 12				149.1	81.5	27.5			212.5	27.5
RM 12-SD	130.6	96	42				194	42		
RMZ 12	130.6	96	42				194	42		
RM 16				208.6	89	35			272	35
RM 16-SD	158.6	109	55				228	55		
RMZ 16	158.6	109	55				228	55		
RMZ 16/2				208.6	89/111.5	35/57.6			272	35/57.6
RM 16/360°SD	179.6	109	55				243	55		
RMZ 16/360°	179.6	109	55				243	55		
RM 25				238.6	113	59			302	59
RMZ 25/1				238.6	113/134	59/80			302	59/80
RMZ 25/2				238.6	113/134	59/80			302	59/80
RM 32				302.6	130	76			366	76
RMZ 32/1				302.6	130/157.5	76/103.5			366	76/103.5
RMZ 32/2				302.6	130/157.5	76/103.5			366	76/103.5
RM 32 m. Fl.				302.6	130/157.5	76/103.5			366	76/103.5
RM 32/1 m. Fl.				302.6	130/157.5	76/103.5			366	76/103.5
RMZ 32/2 m. Fl.				302.6	130/157.5	76/103.5			366	76/103.5

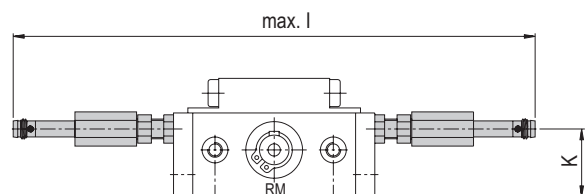
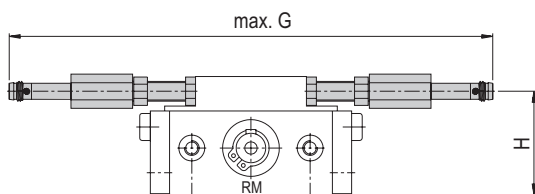
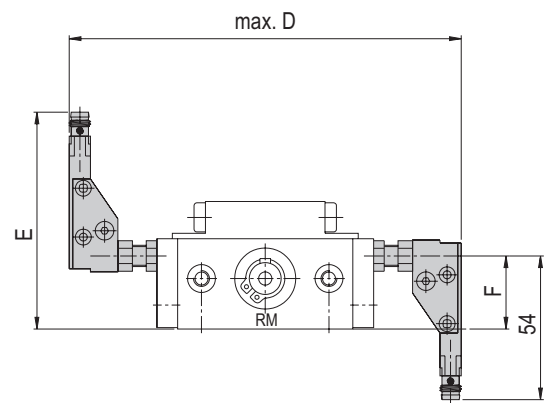
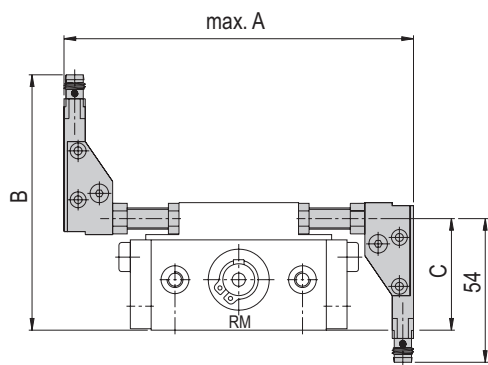

Dimensions when used with angled and straight sensors in mm.

