



Modular industrial design with best-in-class actuator width and column rigidity.



Intuitive HMI reduces setup time and maximizes productivity.

## GSX-E1 Series: Elite Precision

The GSX-E1 Series: Elite Precision is the first of a new generation of ultrasonic welders based on the Branson GSX Ultrasonic Welding Platform, which supports the growing demand for the assembly of smaller and more intricate plastic components. This modular, flexible joining solution provides greater welding precision, control and efficiency, ensuring weld quality and improved operational efficiency.

An advanced actuation system reduces trigger force and improves position accuracy, leading to faster, high-performance welding. This is complemented by hardware and software features that simplify set-up, operation and maintenance, whilst digital connectivity supports Industry 4.0/IIoT applications that provide access to actionable performance and diagnostic data.

### TOP 5 DIFFERENTIATORS

- **Low trigger force**
- **First class** repeatability
- **Force stepping** for maximum force control throughout actuation
- **Smart features** and technologies (find part contact, quick exchange, enhanced graphing etc.)
- **Intuitive** and easy-to-use HMI

### OTHER FEATURES

- **Advanced Actuation System** with the Elite Series patented electro-mechanical servo drive
- **Modular hardware** components to allow easy transfer from one user environment to another (example: modularity from benchtop to automation)
- **Modular Software architecture** with fully electronic controls
- **System Start Up** – Fastest start-up time (system boot up time <60 seconds)
- **Max force:** Up to 2500N
- **Mechanical system resolution** – 0.01 millimeter

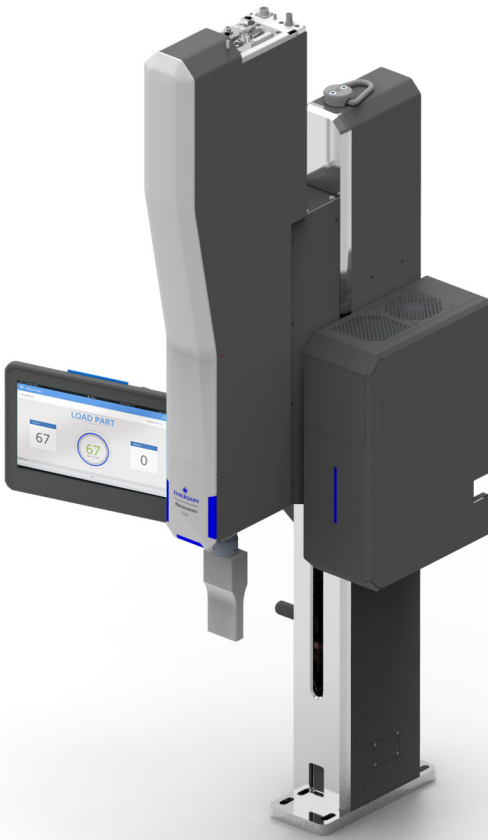

Modular design with easy adaptation to automation.



Connectivity provided by digital I/O and USB ports.

- **Adjustable Actuator Velocity Control**
- **Easy-to-use Quick Stack Exchange system** for <5 minutes tooling change
- **6 weld modes** – Peak power, energy, time, ground detect, collapse, absolute
- **Closed-loop** amplitude, frequency & force control with dynamic follow-through
- **Amplitude and force stepping** for optimization of weld strength and appearance
- **Industry 4.0 capability**
- **NIST Calibration**
- **Faster cycle time** with configurable home and ready positions
- **Enhanced configurable graphing** with graph overlay capability, enhanced data access and enhanced ease-of-use via Position Tracking Ball (PTB)
- **Distance encoder** – Allows for setting absolute and collapse distance with maximum precision
- **Standard Internal Memory** – 200,000 weld history with 1,000 weld graphs
- **12" intuitive primary HMI** that is a projected capacitive touchscreen
- **Four-Level User Authorization** with password protection and programmable permissions
- **USB Ports and Digital I/O**
- **Rigid square column design** design with easy alignment
- **External Tooling Part ID**
- **True Digital Autotune with Memory (AT/M)** – Provides fully-automatic tuning and stores horn frequency at the end of each weld
- **Total Amplitude Control** – Branson digital power supply technology provides complete control of amplitude throughout the weld cycle: programmable starting ramp, digital setting of weld amplitude and energy braking
- **Auto Seek** – Automatically measures stack frequency and stores it in memory. Five selectable Auto Seek choices are available
- **FDA 21 CFR Part 11 Capable**

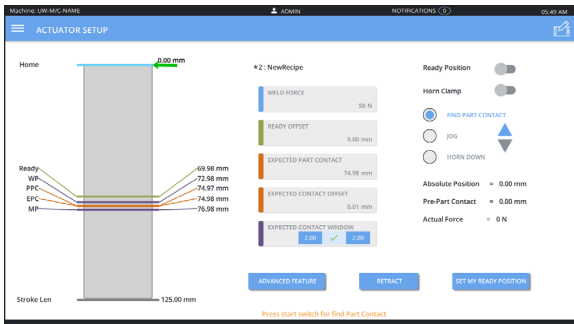

Smart Features and technologies that simplify setup and production processes.

- FDA 21 CFR Part 11 Capability delivering:**
  - Data Retention of weld history
  - User Access Authorization and Security
  - Audit trails of events and changes
- Line/Load Regulation** – Corrects for variations due to power line fluctuations and varying load conditions through the Branson closed-loop amplitude control
- Self diagnostics and monitoring** – visual, audible and logic output alarms
- Selectable Pre-triggering** – Auto, distance, and time
- Variable Dynamic Triggering** – Provides consistent weld quality by triggering ultrasonics after a preset force
- Programmable Starting Ramp** – Adjustable starting ramps from 10 milliseconds to 1.0 second to accommodate starting characteristics of a wide range of horns. This makes it easier to start more difficult horns. When utilizing smaller horns, the starting ramp cycle time can be minimized
- Choice of language for message display** – English, French, German, Italian, Spanish, Japanese, Korean, traditional and simplified Chinese

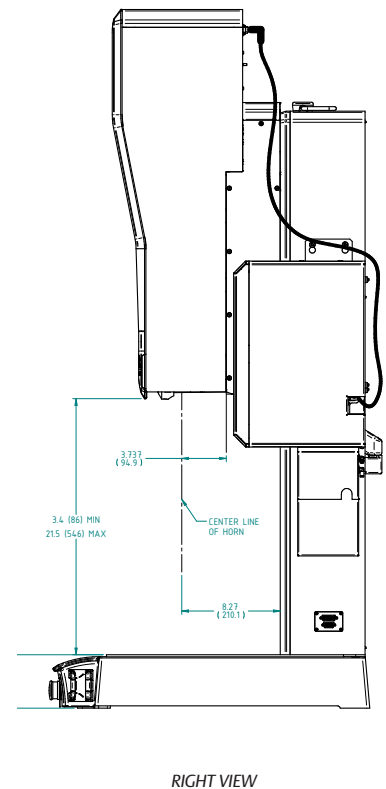
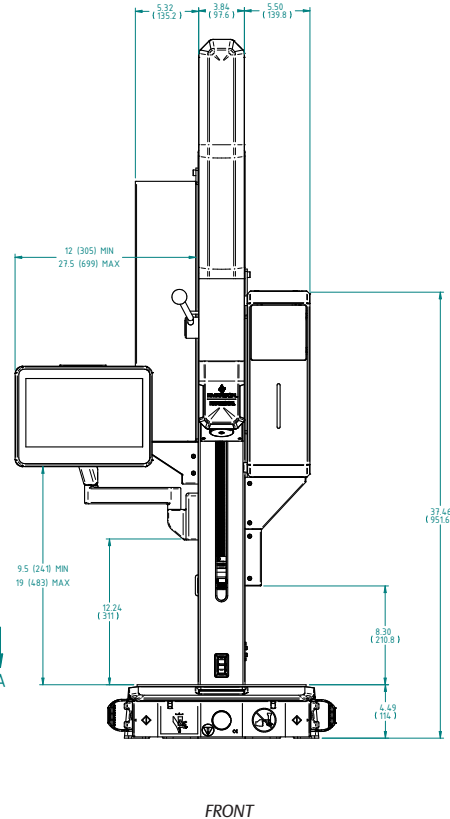
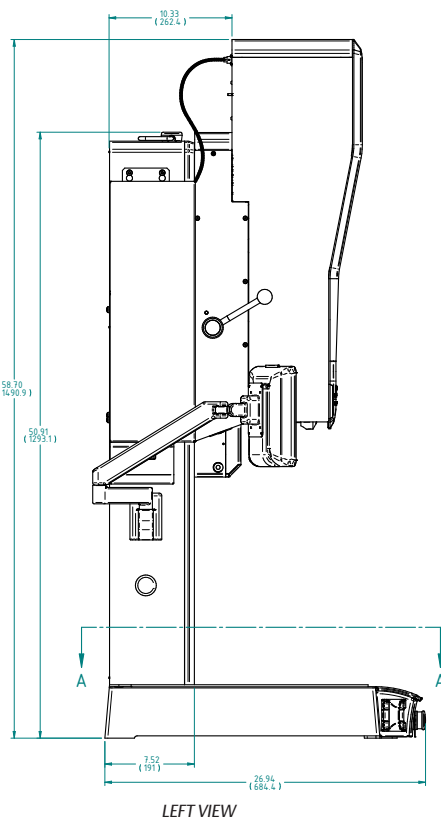

## ACTUATOR OPTIONS

Force Range	Stroke Length (mm/in.)	Minimum Trigger Force (N/lb.)	Max Force (N/lb.)	Weight	Dimensions
Ultra Low – High	125 mm/5 in.	5N/1lb. ▲	2500N/562 lbs.	240 lbs./110kg	1491mm(H)x417mm(W)686mm(D)

## SETUP AND OPERATION

Multiple Weld Mode Control	✓	Converter Cooling Air	✓
Time, Energy, Collapse Distance, Absolute Distance, Ground Detect Modes, Peak Power	✓	1000 Programmable Recipes	✓
Programmable Stroke (Start and Stop Positions)	✓	Programmable Data Streaming	✓
Force Profiling with Adjustable Force Ramp	✓	Alarm History and Audit Trail	✓
Amplitude Profiling	✓	Four-Level User Authorization with Password Protection	✓
Rigid Column with Easy Adjustment	✓	Ergonomic Start Switches	✓
Single-level Password Protection	✓	Unlimited Number of Users	✓
Storage for Last 200,000 Weld with 1,000 Weld Graphs	✓	FDA 21 CFR Part 11 Capable	✓
Graphing with Multi-graph Overlay	✓	<b>OPTIONAL PACKAGES</b>	
Programmable Suspect and Reject Limits	✓	Ground Detect Kit	OPT
Production Counter (Batch and Total Part Counts)	✓	Different Cable Lengths	OPT
Quick-Change-Stack Carriage	✓	Configurable Integration Options for Automation	OPT
		Stainless Steel Package for Cleanroom	OPT

## POWER SUPPLY

Power Supply	20:1.25	20:2.5	20:4.0	30:1.5	40:0.8
Output Power	1250 Watts	2500 Watts	4000 Watts	1500 Watts	800 Watts
Line Voltage	200-240V AC 50/60 Hz				
Max Current	7 amps max	14 amps max	25 amps max	10 amps max	10 amps max
Receptacle Required	NEMA L6-20R (North America specific)				
Frequency	20 kHz	20 kHz	20 kHz	30 kHz	40 kHz
Ambient Temp.Range	41 – 104° Fahrenheit 5 – 40° Celsius				

▲ Set-up Dependent.

The contents of this publication are presented for information purposes only. We reserve the right to modify or improve the designs or specifications of our products at any time without notice.

## Americas

Branson Ultrasonics Corp.  
41 Eagle Road  
Danbury, CT 06813-1961  
T: 203-796-0400  
F: 203-796-9838  
www.Emerson.com/Branson

## Europe

Branson Ultraschall  
Niederlassung der Emerson  
Technologies GmbH & Co. OHG  
Waldstrasse 53-55  
63128 Dietzenbach, Germany  
T: +49-6074-497-0  
F: +49-6074-497-199  
www.Emerson.com/Branson

## Asia

Branson Ultrasonics (Shanghai) Co., Ltd.  
758 Rong Le Dong Road  
Song Jiang, Shanghai, PRC, 201613  
T: 86-21-3781-0588  
F: 86-21-5774-5100  
www.Emerson.com/Branson