

Electrical handling systems

EPS mini gantry s

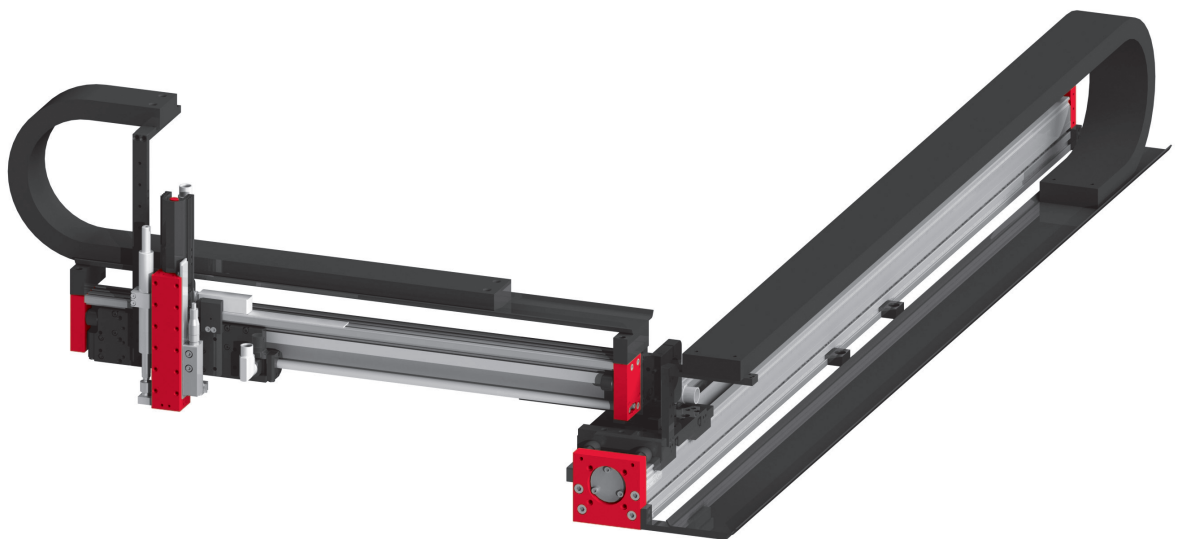

- Lateral boom up to 640 mm stroke
- Ideal for palletizing tasks with low mass
- Optimal accessibility

Dimensions

EPS mini gantry s

Type	A	B	C	D	E	F	G
PDL30-X-D19	X + 270 mm		109 mm	40 mm			
PDL30-X-D20	X + 290 mm		119 mm	50 mm			
PDL40-X-D27	X + 340 mm		144 mm	49 mm			
PDL40-X-D28	X + 370 mm		159 mm	64 mm			
PDL40-X-HP-D27	X + 460 mm		204 mm	49 mm			
PDL40-X-HP-D28	X + 490 mm		219 mm	64 mm			
PEL20-Y-SL		Y + 234 mm			114 mm	B + 56 mm	
PEL20-Y		Y + 314 mm			155 mm	B + 56 mm	
ES20-50-SL							192 mm
ES20-100-SL							285 mm
ES20-200							365 mm
ES20-300							495 mm

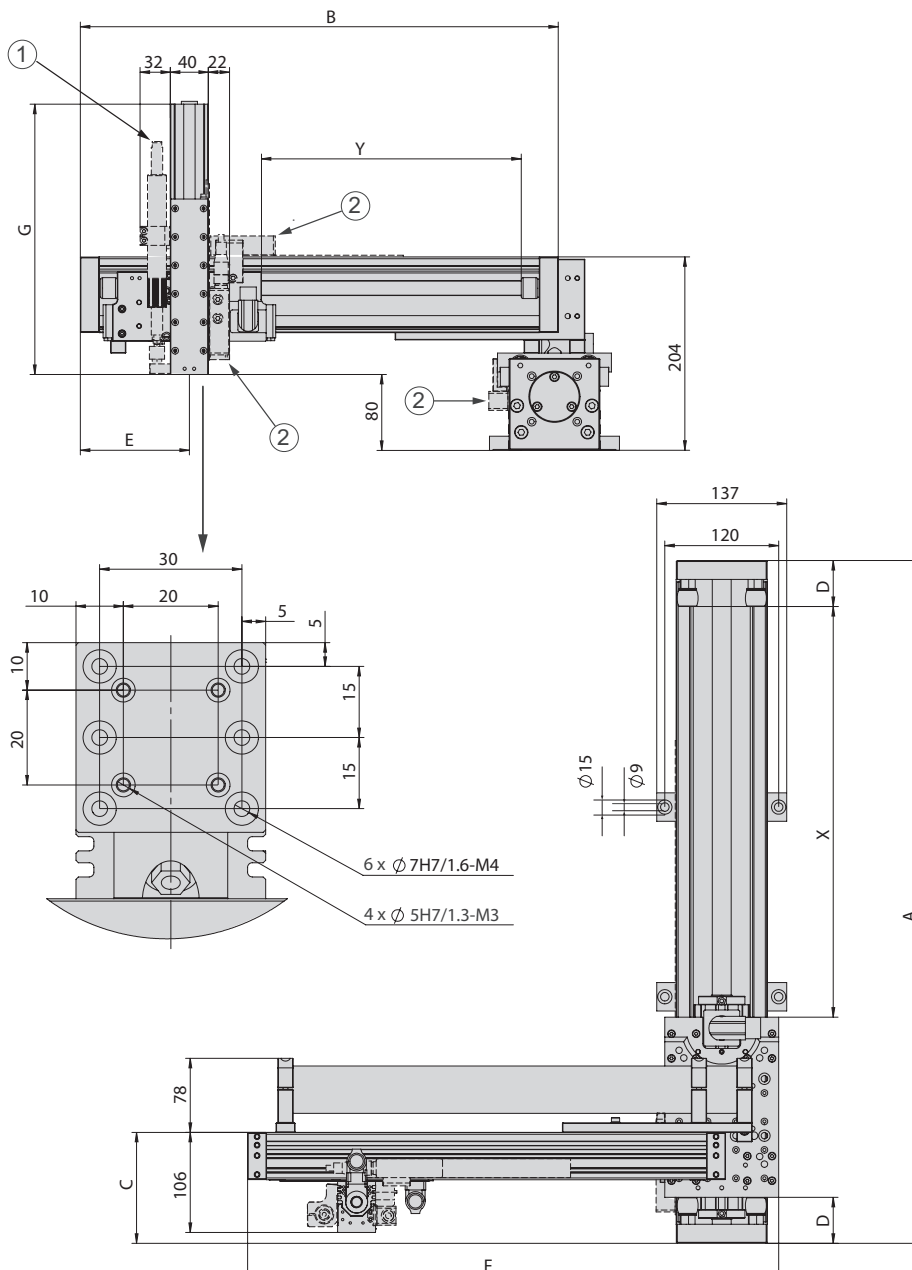

- ① MagSpring
- ② Path measuring system
- X Stroke of the X-axis
- Y Stroke of the Y-axis

EPS mini gantry s			
Order number	50444422		
Drive type	electrical, linear motor		
Repeat accuracy	± 0.05 mm		
- with external path measuring system (1 µm)	± 0.02 mm		
Temperature range	0 ... 50 °C		
Control block with 5/3, 5/2 or vacuum units	up to 6 valves		

Type	X-axis		
Axis	PDL30	PDL40	PDL40-HP
Stroke horizontal	90, 130, 150, 230, 250, 330, 350, 430, 450, 530, 550, 630, 650, 730, 930, 1130, 1330 mm	70, 160, 170, 230, 280, 320, 370, 440, 460, 530, 580, 670, 880, 1060, 1270, 1480, 1660 mm	160, 200, 250, 320, 340, 410, 460, 550, 760, 940, 1150, 1360, 1540 mm
Maximum speed	3.2 m/s	3 m/s	2 m/s
Peak force	255 N	550 N	1024 N
Permanent force	51 N	145 N	203 N

Type	Y-axis	
Axis	PEL20-SL	PEL20
Stroke horizontal	80, 140, 210, 270, 370, 550, 640 mm	60, 130, 190, 290, 470, 560 mm
Maximum speed	6.8 m/s	4.8 m/s
Peak force	67 N	137 N
Permanent force	15 N	31 N

Type	Z-axis	
Axis	ES20	ES20
Stroke vertical	50 mm	100, 200, 300 mm
Maximum speed	6.8 m/s	4.8 m/s
Peak force	67 N	137 N
Permanent force	15 N	31 N

Included in the delivery *

- 2x Ø 5h6 Centring sleeves
- 2x Ø 7h6 Centring sleeves
- MagSpring or compensation spring
- Hose or drag chain
- Motor cable
- Completely wired
- Controller parametrised
- Gantry bracing
- Attachment blocs

Accessories

- (Catalogue HT accessories)
- Valve block
 - Clamping element
- (Catalogue HT components linear)
- Path measuring system
- (Catalog HT components gripping/rotating)
- Rotary module
 - Gripper module

* Deviations possible depending on installed peripherals

Type	ES20-SL	ES20
Dynamic torque Mx	5 Nm	5 Nm
Dynamic torque My	25 Nm	50 Nm
Dynamic torque Mz	25 Nm	50 Nm

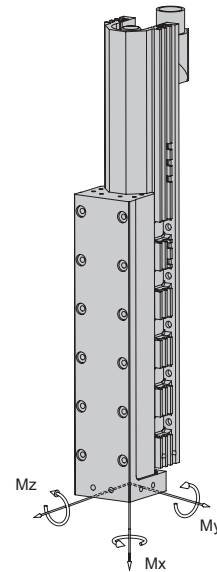

Payload (centric)			
Stroke Y	60 - 270 mm	290 - 370 mm	470 - 640 mm
Stroke Z			
50 mm	4 kg	3 kg	2 kg
100 mm	3 kg	2 kg	1 kg
200 mm	2 kg	1 kg	-
300 mm	1 kg	-	-

Cycle times EPS mini gantry s for Pick & Place

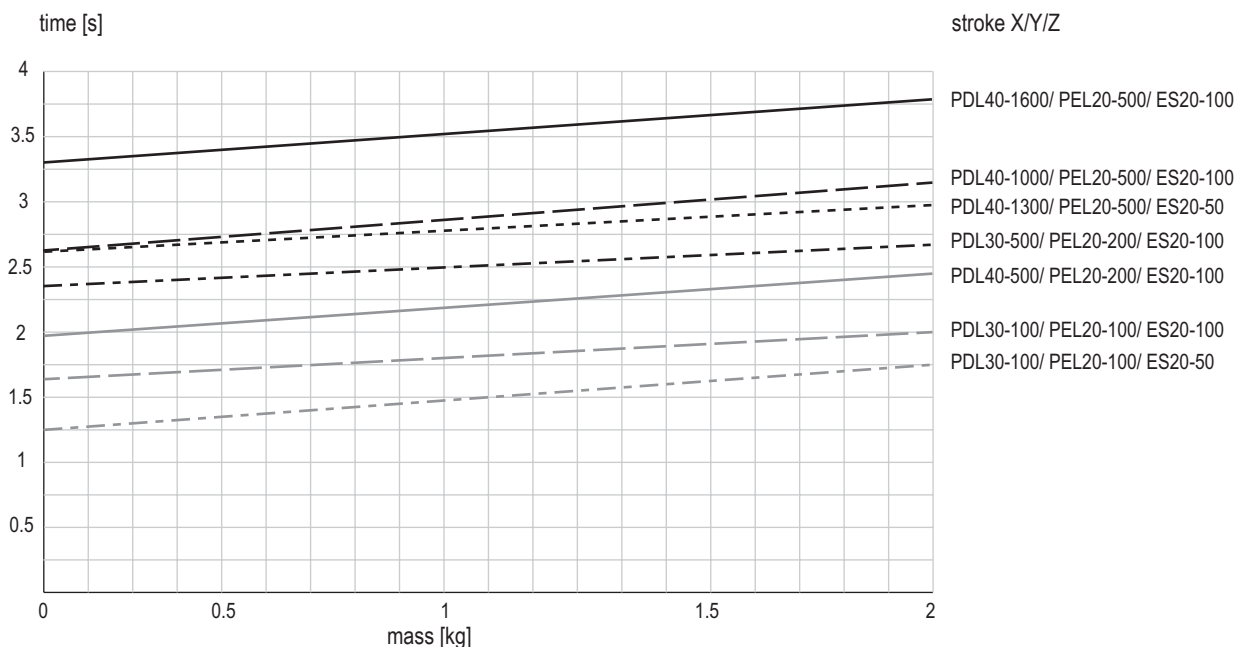

Times including 2 x 100 ms gripping time

Comment:

The values in the chart correspond to a Pick-and-Place cycle (6 subsequent movements + 2 x 100 ms gripping time). The indicated mass is centrally installed at the vertical linear unit. Standstill times of handling permit shorter movement times. In exceptions, e.g. at eccentric mass or high requirements to accuracy, the value may be exceeded.