

# Pneumatically handling systems

## EPS maxi YZ

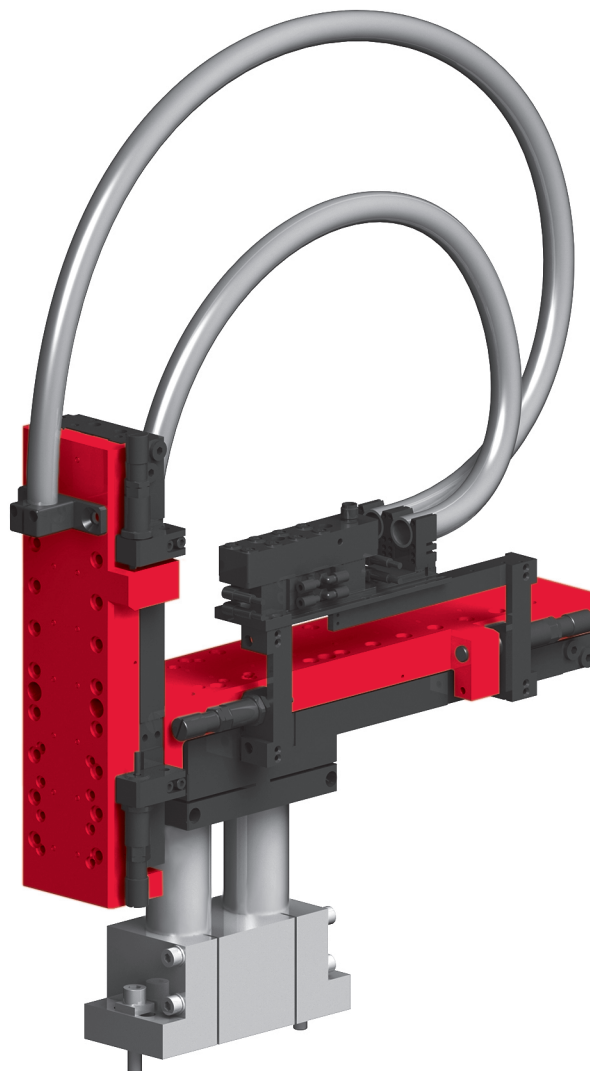

- Compact, fully pre-cabled and pre-piped ready for operation
- Intermediate stop available for Y and Z
- Horizontal and vertical forces up to 305 N

# Dimensions

## EPS maxi YZ

Type	L
CS 25/60	265 mm
CS 25/120	325 mm
CS 25/180	415 mm
CS 25/240	475 mm

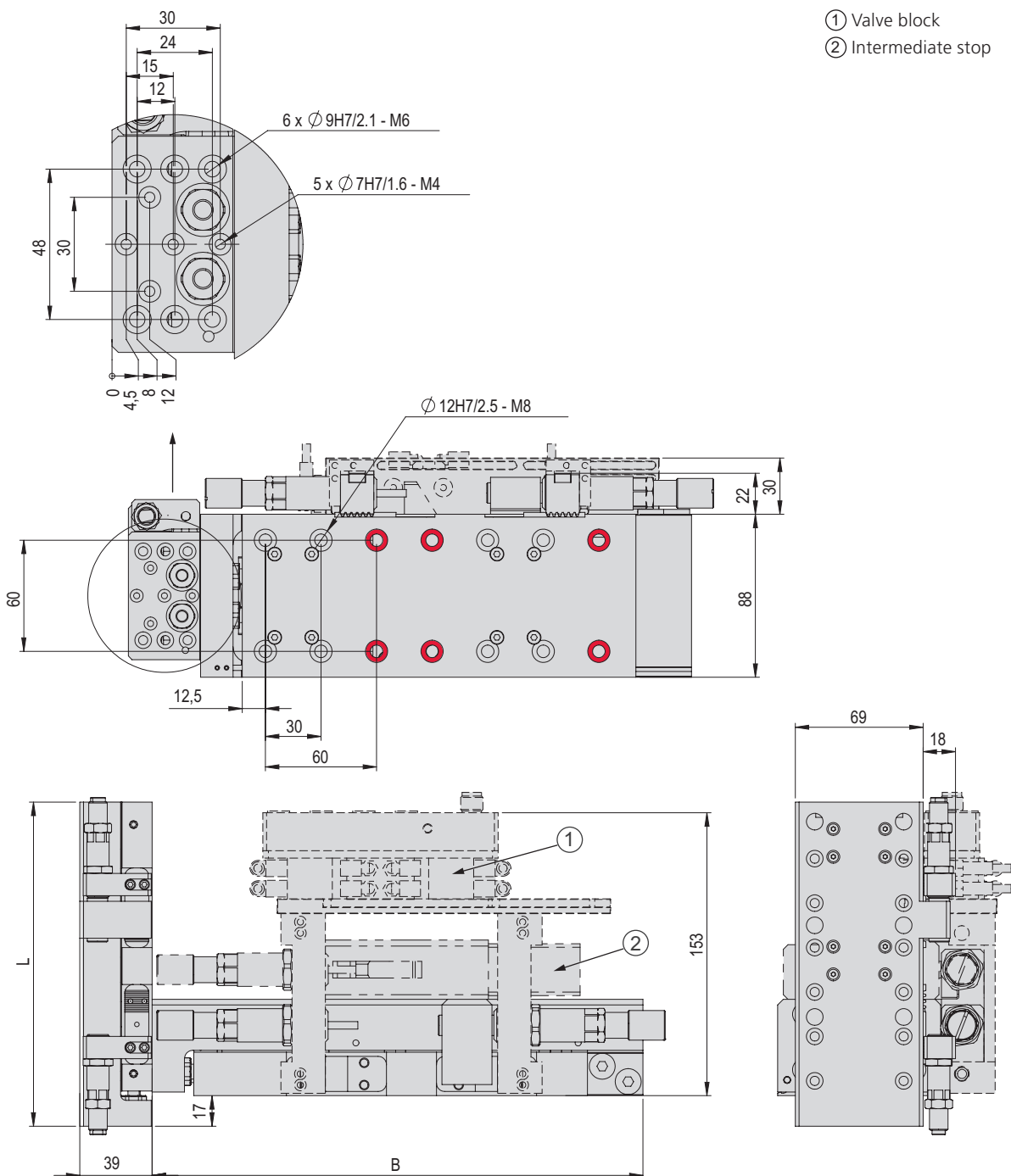

Bores can be screwed through. For additional and differently aligned bores that can be screwed through, see catalogue HT components linear

## EPS maxi YZ

<b>Order number</b>	<b>50456541</b>
Drive type	pneumatical
Repeat accuracy	± 0.02mm
Temperature range	0 ... 50 °C
Control block with 5/3, 5/2 or vacuum units	up to 6 valves

Type	Y-axis
Axis	CS 25
Stroke horizontal	60, 120, 180, 240 mm
Air connection P	G 1/8"
Maximum speed	1 m/s
Retract piston force	245 N
Extend piston force	305 N

Type	Z-axis
Axis	CS 25
Stroke vertical	60, 120, 180, 240 mm
Air connection P	G 1/8"
Maximum speed	1 m/s
Retract piston force	245 N
Extend piston force	305 N

### Included in the delivery \*

- 2x Ø 9h7 Centring sleeves
- 4x Ø 12h6 Centring sleeves
- 4x Special screws M8x35/15
- 4x Shock absorbers
- Hose
- Complete piping/wiring

### Accessories

- (Catalogue HT Accessories)
  - Console
  - Valve block
  - Initiators
- (Catalogue HT Components Linear)
  - Intermediate stop ZA-CS
- (Catalog HT Components Gripping/Rotating)
  - Rotary modules
  - Gripper modules

\* Variations possible, depending on mounted peripheral equipment

Type	CS 25/60	CS 20/180
	CS 25/120	CS 20/240
Static torque Mx	84 Nm	84 Nm
Static torque My	133 Nm	140 Nm
Static torque Mz	112 Nm	120 Nm

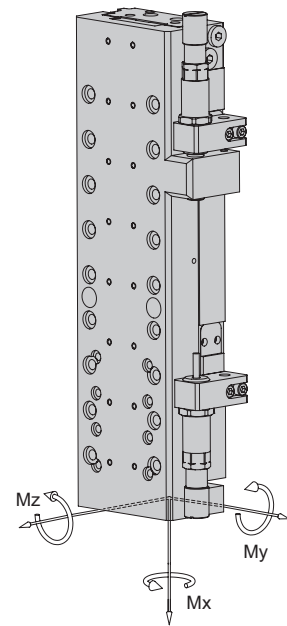

### Cycle times EPS maxi YZ for Pick & Place

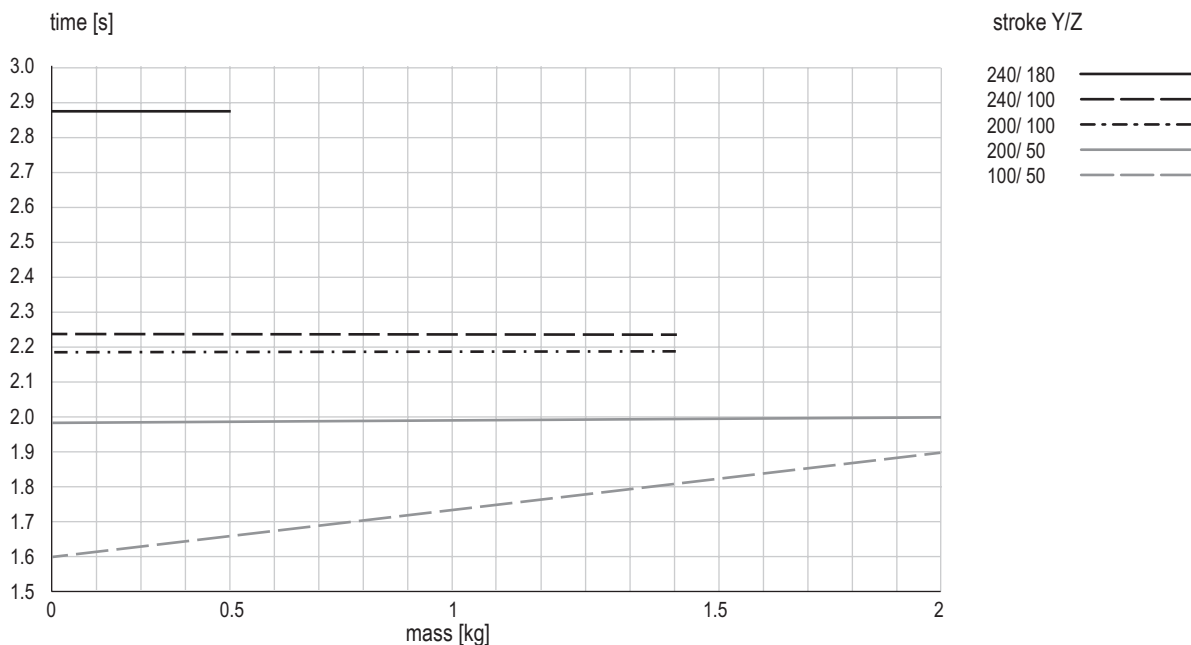

Times including 2 x 100 ms gripping time

**Comment:**

The values in the chart correspond to a Pick-and-Place cycle (6 subsequent movements + 2 x 100 ms gripping time). The indicated mass is centrally installed at the vertical linear unit. Standstill times of handling permit shorter movement times. In exceptions, e.g. at eccentric mass or high requirements to accuracy, the value may be exceeded.