



B452P Ultrasonic Vapor Degreaser

OVERVIEW:

Emerson is the global leader in solvent cleaning technology through our portfolio of Branson products. The Branson B-Series Ultrasonic Vapor Degreasers are a series of environmentally sound, cost effective, precision degreasers.

The B452P integrates decades of degreasing experience with the demanding needs of a changing marketplace. The B452P incorporates important environmental and safety features, including onboard compressors for both primary and sub-zero cooling. The color touchscreen HMI provides users with a complete tool to setup the degreaser with greater ease and offers a wide range of system information for diagnostics and documentation. The B452P is ideal for use with most commercially-available vapor degreasing safety solvents.

KEY FEATURES:

- **Automatic system** start-up and shut-down
- **Ergonomic design** allows simple loading of parts
- **Touchscreen HMI** offers compact, easy to use display and controls
- **Advanced reporting** of production cycles and maintenance information
- **Environmentally friendly** power cover eliminates drafts and helps to prevent solvent loss
- **Energy efficient design** allows improved work space, simple maintenance procedures, and cost savings outside of production hours

SAFETY FEATURES:

In addition to the benefits associated with keeping solvent away from the operator, the B-Series has many other features which contribute to safety and reliability. Key among these are:

- **High-vapor level sensor** to prevent solvent loss
- **Low solvent sensor** to prevent heater damage
- **Boil sump** over temperature alarm
- **100% Freeboard ratio**

OPTIONS:

- Automated Hoist Systems
- Stainless Steel Parts Baskets
- Rotating Parts Baskets
- Desiccant Dryer for Azeotropic Solvents
- Upper Enclosure System
- High-Frequency Ultrasonics

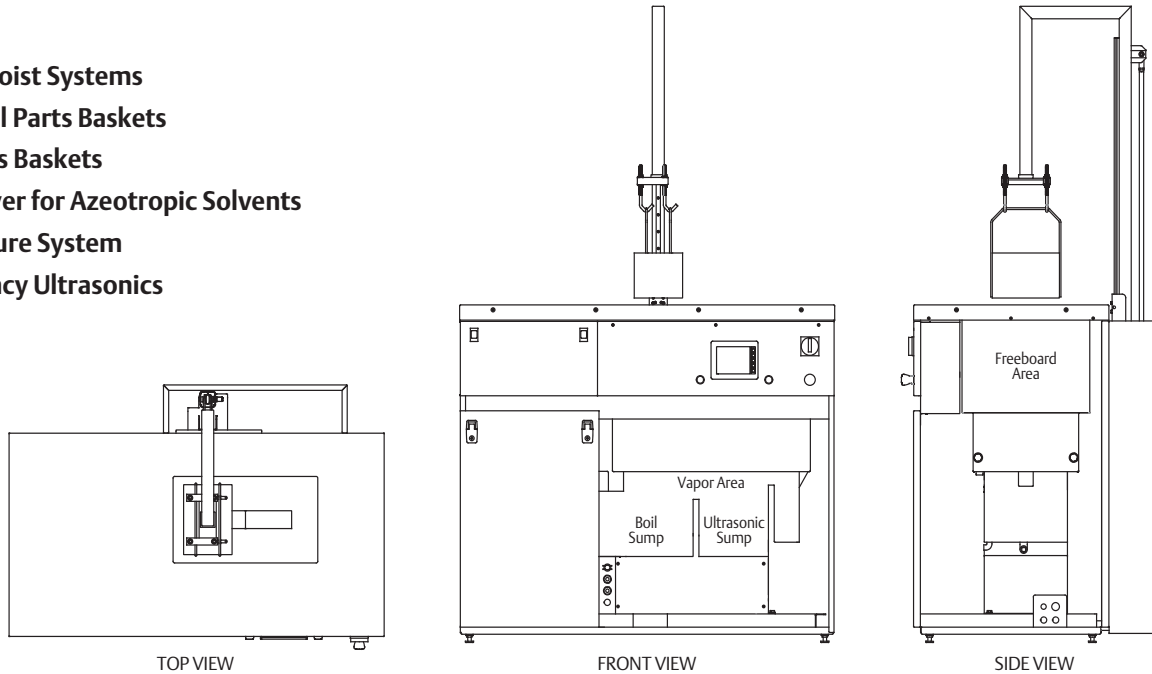

SPECIFICATIONS

	MODEL B452P
Working Dimensions	10" x 12" x 8"D
Boil Sump Heat	2000 W immersion heat
Ultrasonic Heat	400 W
Ultrasonics*	40 kHz
Distillation Rate**	7 gph
Recirculation	1 gpm
Load Capacity**	200 lbs. steel/hour
Vapor Zone	28.7" x 15" x 8.5"D
Solvent Capacity	9.2 gallons
Overall	55" x 28.5" x 46"H
Input Power	208 or 230V, 3Ph, 27A
Shipping Weight	550 lbs. with pallet

*Higher frequencies available upon request. **Based on HFE and HFC solvents.

Americas

Branson Ultrasonics Corp.
41 Eagle Road
Danbury, CT 06813-1961
T: 203-796-0400
F: 203-796-9838
www.Emerson.com/Branson

Europe

Branson Ultraschall
Niederlassung der Emerson
Technologies GmbH & Co. OHG
Waldstrasse 53-55
63128 Dietzenbach, Germany
T: +49-6074-497-0
F: +49-6074-497-199
www.Emerson.com/Branson

Asia

Branson Ultrasonics (Shanghai) Co., Ltd.
758 Rong Le Dong Road
Song Jiang, Shanghai, PRC, 201613
T: 86-21-3781-0588
F: 86-21-5774-5100
www.Emerson.com/Branson