

Issued by	NMi Certin B.V.
In accordance with	<ul style="list-style-type: none"><li>– WELMEC guide 8.8 “General and Administrative Aspects of the Voluntary System of Modular Evaluation of Measuring instruments under the MID”</li><li>– OIML R81 Edition 1998(E) “Dynamic measuring devices and systems for cryogenic liquids”</li><li>– OIML R117-1 Edition 2007(E) “Dynamic measuring systems for liquids other than water”.</li><li>– OIML R137-1 Edition 2006(E) “Gas meters”.</li></ul>
Producer	Emerson Process Management Flow B.V. Neonstraat 1 6718 WX Ede The Netherlands
Measuring instrument	<p>A <b>flow transmitter</b> (calculator/indicating device for Micro Motion Coriolis meters), intended to be used as a part of a measuring instrument.</p> <p>Producer’s mark or name : Micro Motion</p> <p>Designation : 700; 800; 1700; 2500; 2700; 3500 and 3700 (“MVD Series”)</p> <p>Software versions : See paragraph 1.2 of the description</p> <p>Accuracy class : 0,3; 0,5; 1,0; 1,5; 2,5</p> <p>Environment classes : see paragraph 1.2 of the description</p> <p>Temperature range ambient : see paragraph 1.2 of the description</p> <p>Further properties and test results are described in the annexes: – Description TC7057 revision 32; – Documentation folder TC7057-11.</p>
Remarks	<ul style="list-style-type: none"><li>– A description of the model identification codes on the manufacturer identification plate is given in Annex 1 belonging to this Evaluation certificate.</li><li>– This revision replaces the previous versions.</li><li>– The documentation folder is not changed.</li></ul>

Issuing Authority **NMi Certin B.V.**  
29 September 2017



C. Oosterman  
Head Certification Board

**NMi Certin B.V.**  
Hugo de Grootplein 1  
3314 EG Dordrecht  
The Netherlands  
T +31 78 6332332  
[certin@nmi.nl](mailto:certin@nmi.nl)  
[www.nmi.nl](http://www.nmi.nl)

This document is issued under the provision that no liability is accepted and that the applicant shall indemnify third-party liability.

Reproduction of the complete document only is permitted.

## 1 General information on the flow transmitter

All properties of this flow transmitter, whether mentioned or not, shall not be in conflict with the Legislation.

This Evaluation certificate is the positive result of the applied voluntary, modular approach, for a component of a measuring instrument, as described in WELMEC guide 8.8.

The complete measuring instrument must be covered by an EC type-examination Certificate or an EU-type examination certificate.

The Evaluation certificate is valid for the Micro Motion flow transmitters, as described in paragraph 1.1 of the description, and may only be used in combination with Coriolis measurement sensors manufactured by Micro Motion:

- that are covered by one of the following Evaluation certificates: TC7050, TC7056 or TC8064;
- directly mentioned in the EC type-examination certificate or EU-type examination certificate of the measuring system.

The flow transmitter is intended for control of a Coriolis sensor and processing of its Custody Transfer output signals into:

- mass flow rate, mass total and mass inventory;
- actual density, actual volume flow rate, actual volume total and actual volume inventory;
- density at defined reference temperature, volume flow rate at defined reference temperature, volume total at defined reference temperature and volume inventory at defined reference temperature;
- net mass flow rate, net mass total, net mass inventory, net volume flow rate, net volume total, net volume inventory, and concentration.

Note: net means at defined reference temperature and 100% concentration.

Depending on the type, the flow transmitter is equipped with a display or not and can be considered as an electronic calculator / indicating device or an electronic calculator.

Equipment connected to the transmitter's output can be applied to determine the volume under reference conditions and to generate indications and printouts of the measured/calculated quantities.

The MVD series consist of a processor module and a transmitter module, which can have the following configurations:

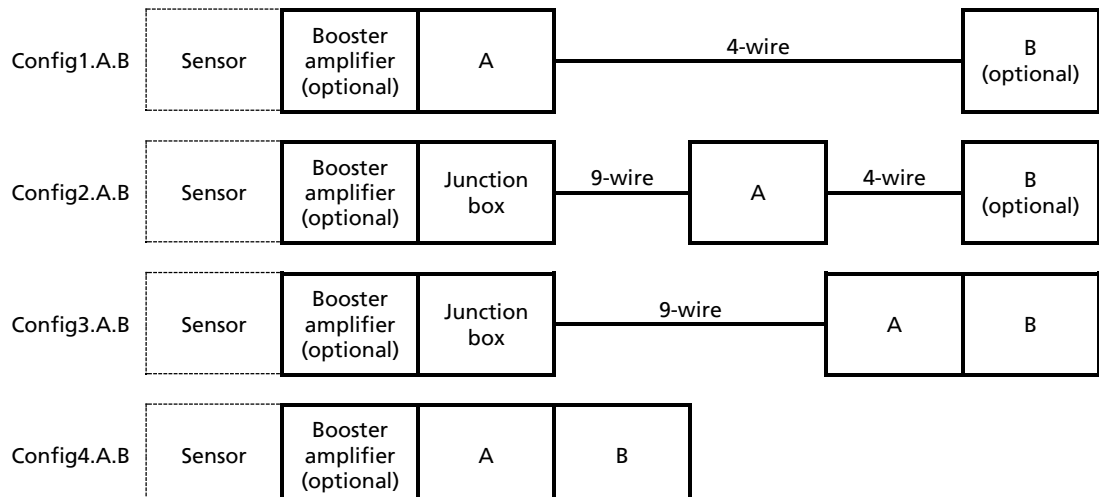

With A and B being numbers, whereby:  
A is indicating the Core-Processor (see below).  
B is indicating the transmitter (see below).

## 1.1 Essential parts

### - **Booster amplifier**

The booster amplifier is a mandatory part of the flow transmitter if connected to a DS600 sensor or a CMF400 sensor with a serial number below 411000 (See Evaluation certificate number TC7056, paragraph 1.2 for details).  
In all other cases, the booster amplifier is optional.

### - **The Core-Processor**

The Core-Processor performs all measurements and calculations and makes the results available to the connected indicating module.

The following models of Core-Processors are possible:

- MVD700, see chapter 2.1 (A=1).
- MVD800, see chapter 2.2 (A=2)

### - **Transmitter module** (optional)

Optional when the core processor is connected directly to a suitable flowcomputer. The transmitter module converts the digital data from the Core-Processor into output signals (for example current output, pulse output).

The following models of indicating devices are possible:

- MVD 1700 / MVD 2700, see paragraph 2.3 (B = 1).
- MVD 2500, see paragraph 2.4 (B = 2).

Remark: The MVD 2500 can only be used in Config1 and Config2 as mentioned in paragraph 1.

- MVD3500 / MVD3700, see paragraph 2.5. (B = 3).

Remark: The MVD 3500 and MVD 3700 can only be used in Config1 and Config2 as mentioned in paragraph 1.

### - **Dual pulse converter** (optional)

A pulse converter, model 510, can be connected to the transmitter module MVD 2500/2700, which converts the two 90° shifted outputs pulses of the MVD 2500/2700 to two 180° shifted output pulses with the same frequency. The pulse width is adjustable. See documentation folder, section 510 pulse converter.

### - **External calculator/indicating device (flow computer)** (optional)

An external calculator/indicating device (flow computer) can be connected to the flow transmitter. The flow computer can be connected to:

- The transmitter module using the available outputs of the transmitter module.
- Directly to the Core processor using the Modbus input and output of the Core Processor. This case is indicated with B = 0.

The flow computer has to be covered by an Evaluation certificate or has to be laid down in the EC type-examination Certificate or EU-type examination Certificate of the measuring instrument.

## 1.2 Essential characteristics

- Ambient temperature range for all parts = -40 °C ... +55 °C
- Environmental classes:
  - E3/M3 for MVD700; MVD800, MVD1700, MVD2700, MVD3500, MVD3700 and the dual pulse converter
  - E2/M2 for MVD2500.
- Software specification (refer to WELMEC 7.2 "Software Guide"):
  - Software type P;
  - Risk Class C;
  - Extensions T, I-5 and I-3 apply.
- Software versions

MVD700 Core Processor		
version	Checksum	date
2.0	51FF	18 December 2001
2.1	2B3F	1 July 2002
2.2	9005	15 April 2004
2.3	D75B	12 May 2004
2.4	474F	13 April 2005
2.5	14AD	20 January 2006
2.6	D732 *)	06 June 2007
2.7	F666 *)	23 April 2008
2.8	1DEA *)	6 August 2008
3.0	D00D *)	1 November 2009
3.0 – ETO17153	97D6 *)	7 December 2009
3.11 – ETO19413 **)	14AD	15 July 2011
3.12	1F1B *)	15 July 2010
3.13 – ETO18951	8BF8 *)	17 August 2011
3.2	18D0	3 December 2012
3.3	B0D1	29 July 2013
3.40	73A9	3 March 2014
3.42	F00C	28 April 2014
3.50	11AA	14 April 2016
3.52	3C4A	28 June 2016

\*) Indicated as 14AD, corrected from v3.2

\*\*\*) Linearization feature



# Description

Number **TC7057** revision 32  
 Project number 1901569  
 Page 4 of 17

<b>MVD800 Enhanced Core Processor</b>		
<b>version</b>	<b>Checksum</b>	<b>date</b>
3.11	891378AB	7 April 2006
3.21	9893B999	16 November 2006
3.30	A73D25DA	13 march 2007
3.42	7FA82CE8	5 October 2007
3.50	D9343F05	3 November 2008
3.52	132CCB63	2 June 2009
3.6	A9CA4E81	15 September 2009
3.61 – ETO17170	9AA358FF	16 December 2009
3.7	BE73CD62	15 July 2010
3.71 – ETO18982	580D32B6	24 May 2011
3.8	8CA8E7D1	15 December 2011
3.81 – ETO20775	7931CE3D	20 September 2012
3.9	58CB3E0C	3 December 2012
3.91 – ETO21156	65F98DD7	27 November 2012
3.94	47EB3E10	8 May 2013
3.96	756C1BFD	29 July 2013
4.00	C582F843	17 February 2014
4.02	8D61C368	13 March 2014
4.14	40860C63	13 August 2015
4.20	2983A9BE	14 April 2016
4.21– ETO21931 *)	D6349259	3 June 2016
4.40	B280233F	28 August 2017
4.42	D7BA0841	27 September 2017

Note: For the 800ECP v3.80 or higher: by writing ETO number 13511 in Modbus register 5005, the linearization feature is enabled.

\*) Density Based Correction coefficients removed. To be used in gas application measuring Hydrogen or Helium.

<b>Software versions with no checksum</b>		
<b>Part</b>	<b>Version</b>	<b>Remark</b>
MVD1700 MVD2700	3.2, 3.3, 3.4, 3.4.1, 3.5.3, 3.6, 3.7, 4.1, 4.2	
MVD2500	4.0, 4.1, 4.2	

<b>MVD1700 / MVD2700 / MVD2500</b>		
<b>version</b>	<b>Checksum</b>	<b>date</b>
5.0/1.0	7A7F0B39	10 October 2006
5.1/1.0	95F0BC47	19 March 2007
5.12/1.0	A14FBFB9	8 May 2007
5.2/1.0	746CBE79	3 March 2008
6.0/1.1	BB615B55	1 July 2009
6.1/1.2	13176BE6	3 August 2010
6.11 – ETO19266	9B13F21A	14 June 2011
6.4/1.3	B77B25C9	9 January 2013
6.5/1.3	88FB1B5C	22 April 2013
6.6/1.3	9ECE81F1	30 October 2013
6.7/1.3	4A5365D4	18 November 2016
7.0/1.3	B77B25C9	9 January 2013
7.1/1.3	88FB1B5C	22 April 2013
7.2/1.3	9ECE81F1	30 October 2013
7.3/1.3	4A5365D4	18 November 2016

<b>MVD3500 / MVD3700</b>		
<b>version</b>	<b>Checksum</b>	<b>date</b>
7.0/1.1	A1C34F1C	11 April 2007
7.1/1.1	D5783FCF	18 January 2008
7.2/1.1	20609FD3	20 February 2009
8.0/1.2	158A12BD	24 August 2010
8.02 – ETO18947	1CC007C4	7 June 2011
8.1/1.3	4279A001	30 January 2012
8.14/1.3	62F125F2	27 April 2012
8.2/1.4	368139C5	28 March 2013
8.21 – ETO23686	D507F464	1 July 2014
8.3/1.4	8F65A9E9	2 April 2014
8.4/1.4	227B10D2	30 July 2015
8.41 – ETO26097	31D36D05	5 April 2016

- Minimum measured quantity  
 The minimum measured quantity is not smaller than the largest of the following values:
  - The minimum measured quantity of the connected sensor;
  - n times the unit of indication of the 1700/2700/3500/3700;
  - n times the unit of indication of a connected additional electronic calculator/indicating (flow computer) device, if applicable;
  - n times the unit of printing, if applicable.

The unit of printing may not be smaller than the smallest unit of indication.

Where n is given in the table below:

Accuracy Class	0,3	0,5	1,0	1,5	2,5
n	500	200	100	100	50

- Custody Transfer parameters  
 The Custody Transfer parameters and the mandatory settings are given in paragraph 1.5 of this Description.
- Security mode:  
 The 700/800 and 1700/2500/2700/3500/3700 have their own fixed ID number. After finalising the parameter settings in the models, the software is set in a secure mode, which means that an XOR operation is made based on both ID's to avoid exchanging modules. At the same time, the CRC checksum based on the configured parameters within the core-processor is stored within model 1700, 2500, 2700, 3500 or 3700 to avoid changing parameters within the core-processor ("marriage of core processor and transmitter").
- Marriage of a core processor to a transmitter is done by software with 1700/2500/2700 and by a hardware switch with 3500/3700. When MVD is in security mode, parameters declared as secured cannot be changed.
- TOTALS/INVENTORIES:  
 Only actual mass total/inventory, actual volume total/inventory, or standard/net (API/C.M.) volume total/inventory can be used to measure a custody transfer transaction. These totalisers/inventories can be read from the transmitter via the display (if configured as such), via pulse output (double channel, phase shifted) or via digital communication (Modbus).

### 1.3 Essential shapes

- Inscriptions
  - At least the inscription "TC7057" is placed on the models mentioned in paragraph 1.1.
  - Identification of the measurement sensor.
  - Close to the display of the 1700, 2700, 3500 and 3700 or (if applicable, see paragraph 1.6) that of the connected flow computer: the minimum measured quantity.
- Status output  
 In case an electronic calculator/indicating device is connected to the 700, 800, 1700, 2500, 2700, 3500 or 3700 the status is sent to the connected device in the following ways:
  - The status is sent directly to the flow computer using the Modbus connection. Applicable for models 700, 800, 1700, 2700, 3500 and 3700.
  - The status output results in interrupting one of the pulse-channels, thus enabling the flow computer to detect a pulse failure and consequently generate an alarm. Applicable for models 2500 and 2700.
  - The MVD status results in a saturated mA output (< 3,6 mA or >21mA) thus enabling the flow computer to detect a failure and generate an alarm. Applicable for models 1700, 2500, 2700, 3500 and 3700.
- Sealing.  
 See chapter 3 of this description.

## 1.4 Conditional parts

- Back-up EEPROM  
 The flow transmitter is provided with EEPROM's for the storage of non-volatile data, in case of power failure.
  - The EEPROM of the Core Processor stores the settings necessary to perform the measuring operation.
  - The EEPROM of the transmitters stores the setting of the outputs of the transmitter.
- Safety barrier  
 Optionally a safety barrier "MVD DIRECT CONNECT", model 3600663 is placed between the core processor and the external calculator/indicating device (flow computer).
- Push-Pull Opto Coupler (optional)  
 Optionally a push-pull opto-coupler is placed between the transmitter module and the external calculator/indicating device (flow computer) for the transmission of pulses over a large distance.  
 The Opto-coupler is of type Phoenix DEK-OE-...xxDC/100KHZ-G or any equivalent  
 See documentation folder page 7057/15-01 for a typical wiring diagram.

## 1.5 Conditional characteristics

- Indications (only applicable for 1700/2700):
  - Software version 3.2: the indication of the mass or volume has 8 characters with standard four decimals (format xxxx.xxxx). When the value 9999.9999 is reached the decimal point is shifted one position to the right (format becomes xxxxx.xxx). When the value 99999.999 is reached, the totaliser continues with indication 0000.0000 (rollover) without creating a "roll-over alarm".
  - Software version 3.3 and higher gives the possibility to select 0 to 4 digits behind the decimal point for the resettable totalisers only.
  - Software versions 3.3 and higher are equipped with a resetting feature (via display and digital communication) for the totals.
  - Software version 5.00/1.0 and higher gives the possibility to configure the display precision of each process variable (0 to 5 decimal digits) and the display update rate.
  - Software version 5.00/1.0 and higher is equipped with four options for resetting the totals: None, via display, via digital communication or via display and digital communication.
- The indication unit can be set on tons or kg respectively m<sup>3</sup> or litres.
- The configuration of Custody Transfer parameters of the MVD must comply with what is given below:
- Settings for the security mode
  - Custody transfer mode for models 1700, 2500 or 2700  
 Setting the system into Custody transfer mode required two steps:
    - Enabling: register 5000: code 3 for 1700 and code 1 for 2500/2700
    - Marrying 700/800 with 1700/2500/2700: via special software program or register 5003: code 7070.
 Note: For 1700/2500/2700 only: Software version 3.3 and higher has the following extra function:  
 Placing the device from the secured state to the unsecured state will now restore the polling address on the connected core processor to 1 (default).  
 Placing the device back into the secure state will change the core processor polling address once again.





# Description

Number **TC7057** revision 32  
Project number 1901569  
Page 8 of 17

See Emerson document TB13-02 Rev. 0 for more details on the software changes.

- Custody transfer mode for models 3500 or 3700  
Setting the system into Custody transfer mode required two steps:
    - Enabling register 5000: code 1;
    - Marrying 700/800 with 3500/3700: via security switch.
  - From software version 3.5.3 (only applicable for 1700/2500/2700):
    - Gives the possibility to view the life zero on the MVD display;
    - Allow the totalisers to be reset via HART when flow is zero and secure mode is enabled.See Emerson document TB06-03 Rev. 0 for more details on the software changes.
  - From software version 3.6 (only applicable for 1700/2500/2700):
    - Issued primary to provide a definitive means for customers with blind MVD transmitters to determine the exact software revision, since only display has the resolution to show more than the 10's digit of a version number (e.g. v3.53 shows as v3.53 on the display, but as v3.5 in HART and Modbus).See Emerson document TB17-03 Rev. 0 for more details on the software changes.
  - From software version 5.00/1.0 (only applicable for 1700/2500/2700):
    - Separation of the Custody Transfer mode through the World Area Selection. Selectable is NTEP (all parameters secured) and OIML (only W&M parameters secured).
    - Frequency output can be set to a simulation mode. Only if the instrument is not in Custody transfer mode (requires breaking of a seal).See Emerson document TBFY07-002 Rev. A for more details on the software changes.
- From software revision 6.0 (only applicable for 1700/2500/2700):
- Added the feature Field Verification Zero as one of the standard selections for the display process screen (requires software version 3.0 or higher for 700CP and version 3.5 or higher for 800ECP).
  - Added the feature Last Measured Value/Time-out to alarm A115 (external P- and/or T-transmitter are not responding).
  - Added the correction temperature (TCORR) to the API corrected volume flow screen, API corrected volume total and inventory screen, corrected density screen and CTL screen.
- Low flow cut off settings  
The low flow cut off for mass flow and the low flow cut off for volume flow shall not be more than one fifth of the minimum flow rate of the connected sensor.
- Density cut off (only applicable to the 700)
  - Software version 2.0: the volume still shows a live value when density falls below the density cut off.  
See Emerson document TB01-02 Rev. 1 for more details on the software changes.
  - Software version 2.1 and higher: the volume flow indicates zero when density falls below the density cut off.  
See Emerson document TB06-03 Rev. 0 for more details on the software changes.
- Damping settings
  - Flow: maximum damping time is 1.6 s.
  - Density: maximum damping time is 1.6 s.
  - Temperature: maximum damping time is 4.8 s.



# Description

Number **TC7057** revision 32  
Project number 1901569  
Page 9 of 17

- Slug flow settings  
The maximum slug flow duration is 2 s.
- Last measured value fault time out settings  
The maximum value for "Last measured value fault time out setting" for mA and for pulses (one setting) is 2 s.

## 1.6 Conditional shapes

- Printed Ticket (if applicable)
  - See the Evaluation/Parts certificate of the applied flow computer if the printer is connected to the flow computer.
  - In case a printer is connected to the 3500/3700, at least the following information is printed:
    - Unique information, identifying the delivery.
    - Delivered mass and/or volume under metering conditions.
    - Identification of the delivered product.
    - A message indicating if alarms have occurred during the delivery.  
Optionally the following information can be printed:
      - Delivered volume under reference conditions, In this case it is mandatory to print the reference conditions.
      - When the printer is to be used in road vehicle applications and is being powered directly by the on board road vehicle battery, a suitable power conditioner is required to comply with the road vehicle battery disturbance requirements.

## 1.7 Non essential parts

- Bunker manifold switch.  
Only present in case of the marine bunkering application. Determines if the valve (transfer point) is open or closed.
- Two warning lights to indicate the aeration level of the ongoing batch.

## 1.8 Non essential Shapes

- Optionally the display is equipped with a backlight.

## 2 Information about the main essential parts of the flow transmitter

### 2.1 MVD700 Core-Processor

#### 2.1.1 Essential parts

There are two hardware versions of the MVD700:

- MVD700 v1; identified with part number 20000843;
- MVD700 v2; identified with part number MMI-20025250.

Please note that the outside look of the v2 is identical (besides the sticker with the part number) to the v1 Core Processor and is therefore not documented.

The software is for both versions identical.

See the documentation folder, section MVD700 Core Processor.

#### 2.1.2 Essential characteristics

- Inputs to the MVD700
  - Two pick-off signals, analogue millivolt signals from which the mass flow and the density are determined.
  - One three-wire PT-100 temperature input for measurement of the sensors tube temperature.  
 Note: this temperature may not be used for converting actual volume to a volume at standard temperature.
  - Modbus input for:
    - Pressure to correct the effect of the fluid pressure on the vibration characteristics of the measurement sensor.
    - Temperature for conversion of actual volume to standard volume.  
 Note: this temperature may also be used as the sensors tube temperature.
- Outputs of the MVD700
  - Alternating current to set the sensors tubes into vibration. The frequency of this current is controlled at the resonant frequency of the tubes.
  - Modbus for output of the various parameters (for example mass total) to an approved device (for example the transmitters mentioned in this Evaluation certificate).
- Provides the following functions:
  - Read – write access to the digital communication interface of all configuration data.
  - Stores the Flow Cal Factor (FCF) in non-volatile memory.
  - Stores the density calibration factors (K1, D1, K2, D2, and FD) in non-volatile memory.
  - Stores the temperature coefficients (slope, offset) in non-volatile memory.
  - Provides a calibration procedure for setting the mechanical zero and stores the result in non-volatile memory.
  - Stores damping factors for flow, density and temperature in non-volatile memory.
  - Provides configuration of units for mass flow, volume flow, density, pressure, and temperature.
  - Stores slug flow (density) limits and slug flow duration in non-volatile memory.
- Custody Transfer software
  - Mass determination:  
 The time shift between the two pick-off signals is representative for the mass flow of the fluid flowing through the connected measurement sensor. Mass flow is calculated with corresponding equation.  
 See Evaluation Certificate TC7056 for conditions on determining the Flow Temperature Coefficient (FT) of the individual sensor.
  - Density determination:

The core-processor controls the measurements tubes in such a way that they vibrate with the resonant frequency. The resonant frequency is representative for the actual density in the sensor and is calculated with corresponding frequency.

See Evaluation Certificate TC7056 for conditions on determining the Density Temperature Coefficient (DT) of the individual sensor.

- The Micro Motion meters are calibrated in such a way to represent the mass in vacuo (and not weight or mass in air or apparent mass) and density in vacuo (and not density in air or apparent density).
- Mass and/or Density can be presented in vacuo (default setting) or in air.
- When Mass and/or Density are/is to be presented in air, the Mass Factor and/or the Dens Factor must be used:



The Factor depends on the actual fluid density and/or ambient air density and is always < 1; therefore these Factors are application specific.

- A security tape label with the text: "Mass in air and/or Density in air" is added close to the indicating device.
- Volume determination:  
 From the measured mass and density, the core processor calculates the volume of the fluid flowing through the sensor.  
 See Evaluation Certificate TC7056 for conditions on determining the FT and DT Coefficient of the individual sensor.

- Volume conversion to reference conditions:

- Volume conversion using API table's
  - \* API table's 5A, 5D, 6C, 23A, 23D, 24C, 53A, 53D and 54C.
  - \* With Core Processor version v2.5 and higher, also using API table's 5B, 23B or 53B.

The standard temperature is programmable when using table's 53A, 53B or 53D.

- Using the concentration measurement feature for density and volume at a defined reference temperature for any liquid for which a traceable database or norm/standard is available. For example, Bio fuels.

Also, see Chapter 4 Conditions for Conformity Assessment.

The concentration measurement feature uses manually configured tables in the Core Processor. These tables are stored behind seal, e.g. they cannot be modified when the instrument is in Custody Transfer mode.

- Concentration measurement feature for measuring alcohol, alcohol percentage and alcohol volume at 20 °C (100% alcohol).  
 For using the concentration measurement feature on alcohol, it is always (independent of temperature) necessary to determine the FT and DT values of the individual sensor.
- When using volume conversion the temperature of the fluid has to be measured with an external temperature probe.  
 It is not allowed to use the temperature probe of the connected measurement sensor.
- Volume conversion to reference conditions is not allowed in combination with the MVD 2500 transmitter

- Corrections

The MVD700 core processor automatically corrects for temperature effects on the sensor's measurement tubes, using the read-out of the sensor's internal temperature transmitter.

Software versions 2.1 and higher support an improved formula for temperature correction for temperatures lower than 0°C.

- If needed, depending on the size of the sensor, automatically correction for pressure can be applied via an external pressure transmitter using the digital communication protocol HART Bell 202.
- LD-Optimisation, software version 3.0-ETO17153 and software versions 3.1 or higher. The LD-Optimisation shall be used when the flow transmitter is connected to certain types of Micro Motion Coriolis sensors and measuring certain types of liquids. See documentation TC7057/26-01 "LD Optimisation" for details.

The LD-control parameter has the following settings:

- 0 = LD Optimisation is off
- 1 = LD Optimisation using hard coded coefficients in the software. Each Coriolis sensor has its own unique set of coefficients
- 2 = LD Optimisation using reference density and a set of programmable parameters
- 3 = LD Optimisation using actual density and a set of programmable parameters

The LD-control parameter and subsequent parameters (for LD control = 2 or 3) are stored behind seal.

- The MVD700 Core Processor can be changed with another MVD700.
  - This is under the condition that the Weights and Measures parameters from the old MVD700 are transferred to the new MVD700 and that the new MVD700 is zero-ed via the auto-zero function.
  - Exchanging the MVD700 Core Processor requires breaking of the seal of the connected transmitter.

## 2.2 MVD800 Core-Processor

The MVD800 Enhanced Core Processor is mainly the same as the MVD700.

### 2.2.1 Essential parts

There are three hardware versions of the MVD800:

- MVD800 v1; identified with part number 20006069;
- MVD800 v2; identified with part number 20016889;  
This is the same as the v1 but equipped with RoHS components (Restriction of Hazardous Substances).
- MVD800 v3; identified with part number MMI-20020807.

The software is for all versions identical.

See the documentation folder, section MVD800 Core Processor

### 2.2.2 Essential characteristics

- See the essential characteristics of the MVD700
- Additions of the MVD800 in respect to the MVD700:
  - Meter Verification (off-line) feature (only possible if the instrument is not in Custody Transfer mode, this requires breaking of the seal).  
Meter verification is comparing the current sensor characteristics with the previously stored (initial) characteristics.
  - Smart Meter Verification (on-line), software version 3.60 or higher.  
Can be used in Custody Transfer mode, as it has no influence on the measurement accuracy.
- Custody Transfer software
  - LD-Optimisation and marine bunkering application:  
Software version 3.61-ETO17170 and software versions 3.7 or higher.

See the description of the LD-Optimisation in the description of the MVD700.

- The MVD800 Enhanced Core Processor can be changed with another MVD800.
  - This is under the condition that the Weights and Measures parameters from the old MVD800 are transferred to the new MVD800 and that the new MVD800 is zero-ed via the auto-zero function.
  - Exchanging the MVD800 Enhanced Core Processor requires breaking of the seal of the connected transmitter.

## 2.3 MVD 1700 / MVD 2700

### 2.3.1 Essential parts

See the documentation folder, section MVD2700 flow transmitter.

- Power Supply
  - The MVD 1700 / MVD 2700 is equipped with a universal power supply, rating:
    - 85 – 265 V AC, 50 – 60 Hz;
    - 18 – 100 V DC.
- Main electronics board
  - The main electronic board reads the parameters from the Core Processor and converts the results into various outputs.
  - There are 2 variants:
    - CONFIG I/O (not for the MVD 1700) (model code "2700\*\*\*x\*\*\*y\*", x = B or C, y = W or D)
    - ANALOG BRD (model code "x700\*\*\*A\*\*\*y\*", x = 1 or 2, y = W or D)
- Display with infra-red buttons (optional)
  - Measured variables and parameters can be viewed on the display, using two infrared buttons and a "menu" dialog system.

### 2.3.2 Essential characteristics

- Inputs of the MVD 1700 / MVD 2700
  - Modbus from the Core Processor
  - Optionally digital reading of pressure and/or temperature through the HART, BELL202 protocol over the current output.  
The Hart signals are superimposed on the DC-current of the output.
- Outputs of the MVD 1700 / MVD 2700
  - In case of ANALOG BRD:
    - Current output for density
    - Modbus RS485 output of the various parameters (for example mass total) to an approved indicating device (flow computer)
  - In case of CONFIG I/O:
    - Double, phase shifted, pulse output for the transmission of mass- or volume-information (90°; 180° and quadrature with flow direction).  
This output is also used as status output.
    - Current output for density.
- In case only the mass indication is a custody transfer value, the indication of the volume shall be prohibited or a label with the text "volume not to be used for custody transfer" is applied.

### 2.3.3 Conditional parts

- Housing

The housing is executed in different forms depending on the configuration (see diagram in point 1) and can be used in a hazardous area.

## 2.4 MVD 2500

### 2.4.1 Essential parts

See the documentation folder, section MVD2500 flow transmitter.

- Power supply  
Ratings: 24 V DC
- CONFIG I/O  
Reads the parameters from the Core Processor and converts the results into various outputs.

### 2.4.2 Essential characteristics

- Inputs of the MVD 2500
  - Modbus from the Core Processor
  - Optionally digital reading of pressure and/or temperature through the HART, BELL202 protocol over the current output.  
The Hart signals are superimposed on the DC-current of the output.
- Outputs of the MVD 2500
  - Double, phase shifted, pulse output for the transmission of mass- or volume-information (90°; 180° and quadrature with flow direction).  
This output is also used as status output.
  - Current output for density.
- The MVD 2500 has a combined Modbus output and service port. To gain access to the service port a "special" communication connection has to be made within 10 seconds after power up of the module. In order to prevent the unauthorised changes of parameters this port may not be physically wired when the module is in Custody Transfer mode.

## 2.5 MVD 3500 / MVD 3700

### 2.5.1 Essential parts

See the documentation folder, section MVD3000 flow transmitter.

- 4 wire Coriolis Card  
Reads the parameters from the Core Processor and converts the results into various outputs via the application card.
- Power Supply  
The MVD 3500 / MVD 3700 can be equipped with a power supply, with the following rating:
  - 85 – 265 V AC, 50 – 60 Hz or 18 – 100 V DC.
- Display  
Backlit LCD, 128 x 128 pixel bitmap

### 2.5.2 Essential characteristics

- Inputs of the MVD 3500 / MVD 3700
  - Modbus from the Core Processor



# Description

Number **TC7057** revision 32  
Project number 1901569  
Page 15 of 17

- Optionally digital reading of pressure and/or temperature through the HART, BELL202 protocol over the current output.  
The Hart signals are superimposed on the DC-current of the output.
- Outputs of the MVD 3500 / MVD 3700
  - Two 4 – 20 mA outputs for the transmission of the density. The first current output can also read external temperature and/or pressure using HART, BELL202.
  - Modbus RS485 output of various parameters (e.g. mass total) to an approved indicating device (flow computer).
  - Printout of the delivery via RS485 port using the FDW-protocol or the Epson protocol.
    - Note 1: The RS485 port can be configured for:
      - Modbus output OR
      - Printer output OR
      - Dual functionality. In idle mode Modbus, with PRINT command in printer mode and after printing fall back to Modbus mode.
    - Note 2: for the FDW-protocol, the FDW-controller/printer from Dohmann GmbH is needed.
    - Note 3: For the Epson protocol a RS485-RS232 converter is needed with RTS control (for example KK systems, type K2-ADE-TB) and a printer with the Epson protocol (for example Epson, type TM-T88V).
    - Note 4: In dual functionality mode an external switching device is required which is controlled by one discrete output of the **MVD 3500 / MVD 3700**, which is assigned to RS485 DUAL FUNCTIONALITY.
- The custody transfer value(s) is put between asterisks (e.g. \*123456 \* kg).

Please note that the following software versions can be used for all applications, not only marine bunkering. The marine bunkering functionality can be enabled/disabled when the instrument is in the unsecured mode (requires breaking of the seal).

- Software version 8.0/1.2 and higher incorporates special features used when bunkering marine fuels (heavy fuel oils / bunker fuel):
  - Dedicated printout for bunkering. See example ticket in the documentation folder.
  - The amount of aeration (air inclusion in the fluid) is calculated from the measurement sensor signals, presented on screen (after MMQ has been delivered), and presented on the ticket. See document T10265 – Aeration – 1 for details on the parameter settings. Changing the aeration setting requires breaking of the seal.
  - Two warning levels are defined for aeration, the warning levels are programmable and settings are secured behind a seal.
    - If the amount of aeration exceeds the defined level:
      - A warning is displayed on the display.
      - And, if present, the corresponding warning light goes on.
  - One discrete input must be assigned to “read” the bunker manifold switch for open/close position.
  - Optionally, two discrete outputs are assigned to the aeration warning lights.
  - Acceptance criteria are added to the ticket and used to declare a batch valid or not.
- Software version 8.1/1.3 and higher:
  - Added is the Epson printer protocol containing off-line detection, paper-out detection and data transmission check.
  - See Emerson document MMI-SB-054 of January 2012 for more details on the software changes.





# Description

Number **TC7057** revision 32  
Project number 1901569  
Page 16 of 17

- Software version 8.2/1.4 and higher:
  - Aeration limit/amount has been replaced by an Aeration Indicator (Yes or No) which is always displayed.
  - Depending on the (secured) settings the mass inventories are printed or not.
  - Display and ticket synchronised in showing mass in vacuum or mass in air.
  - See Emerson document MMI-SB-078 of April 2012 for more details on the software changes.

## 3 Seals

- After setting the model 1700 or 2700 in Custody Transfer mode, the access to the service port is sealed to avoid unauthorised changing of parameters.  
See documentation folder, section Sealing.
- After setting the model 2500 in custody transfer mode:
  - The connections to the service port must be removed and the connections sealed to avoid connecting to the service port. This sealing also prevents the Modbus from being used.
  - Only when multiple model 2500's are placed in the same housing, the housing in which they are placed is sealed against unauthorised opening. This sealing prevents the changes to the wiring of the pulse output and the current output.  
See documentation folder, page 7057/00-19.
- After setting the model 3500 or 3700 in Custody transfer mode:
  - The access to the security switch is prevented with a seal to avoid unauthorised changing of parameters.
  - In case of marine bunkering application: an additional seal is required to prevent bridging of the bunker manifold switch / liquid detector.  
See documentation folder, page 7057/08-01.
- In case configuration Config2 or Config3 is used:  
The 9-wire connection between measurement sensor (junction box) and Core processor is sealed at both ends against opening. See documentation numbers 7057/15-02, 7057/15-03 and 7057/15-04.
- In case of marine bunkering application, the marine bunkering switch must be sealed against removal.
- If present, the housing in which the push-pull opto-coupler is placed is sealed against opening. This to prevent access to the wiring of the pulse output.
- For the seals of the connected electronic calculator/indicating device, if applicable, see the applicable Evaluation Certificate.

## 4 Conditions for Conformity Assessment

- The use of this Evaluation Certificate is limited to:
  - Other parties may use this Evaluation Certificate only with the written permission of Emerson Process Management Flow B.V., Neonstraat 1, 6718 WX Ede, the Netherlands.
- Cabling
  - Cabling has to be in accordance with manufacturer installation instructions.
  - The use of the Micro Motion cable between the MVD700 and the MVD 2500 is mandatory.
- In case of using the concentration measurement feature<sup>[1]</sup>, the initial verification must include the correctness of the configured table. This to verify that the conversion does not exceed the limits as defined for software calculations.
- The (Enhanced) Core Processor is equipped with factors for density and volume, as also mentioned in paragraph 2.1.2 "Essential characteristics", hyphen "Custody transfer software", bullet "Density determination".  
 These factors can be used to adjust the density and volume measurement in case density and/or volume are outside the allowed limits but still are within a band of two times the allowed limits. Using the factors applies to a linear shift in the measurement.

## 5 Reports

An overview of performed tests is given in the test reports:

- |  |                            |
|--|----------------------------|
| - No. CVN201269-1                                      | issued by NMI Certin B.V.  |
| - No. CVN-410178-4                                     | issued by NMI Certin B.V.  |
| - No. CPC-307228-1                                     | issued by NMI Certin B.V.  |
| - No. CPC-607580-1                                     | issued by NMI Certin B.V.  |
| - No. CPC-610406-2                                     | issued by NMI Certin B.V.  |
| - No. DDC/22/G070447-D4                                | issued by LNE              |
| - No. 07060402.emc                                     | issued by TÜV Rheinland BV |
| - No. CPC-710466-1                                     | issued by NMI Certin B.V.  |
| - LD Optimisation/Aeration <b>(1)</b>                  | issued by NMI Certin B.V.  |
| - No. 1700 analog HART<br>Temperature Test, 3 May 2011 | issued by Micro Motion     |
| - No. NMI-11200214-01                                  | issued by NMI Certin B.V.  |
| - No. NMI-11200345-2                                   | issued by NMI Certin B.V.  |
| - No. NMI-SO13204037-01                                | issued by NMI Certin B.V.  |
| - No. NMI-SO14200881-01                                | issued by NMI Certin B.V.  |

**(1)** The test results are stored in the technical file at NMI.

**(2)** The Push-pull Opto-Coupler is not tested, because:

- The transmitters pulse output is tested with long wires attached, and showed no problems during the tests. These long wires are now replaced with short wires.
- The approved external flow computer has passed the same tests and incoming pulses (double channel) are checked for faulty pulses.

Thus, the secure transmission from pulses to the external flow computer is still guaranteed.

<sup>[1]</sup> Also valid when the concentration measurement is used for measuring alcohol as described on page 10. In this case OIML Recommendation R22 "International Alcoholometric Tables" is used to verify the calculation results.

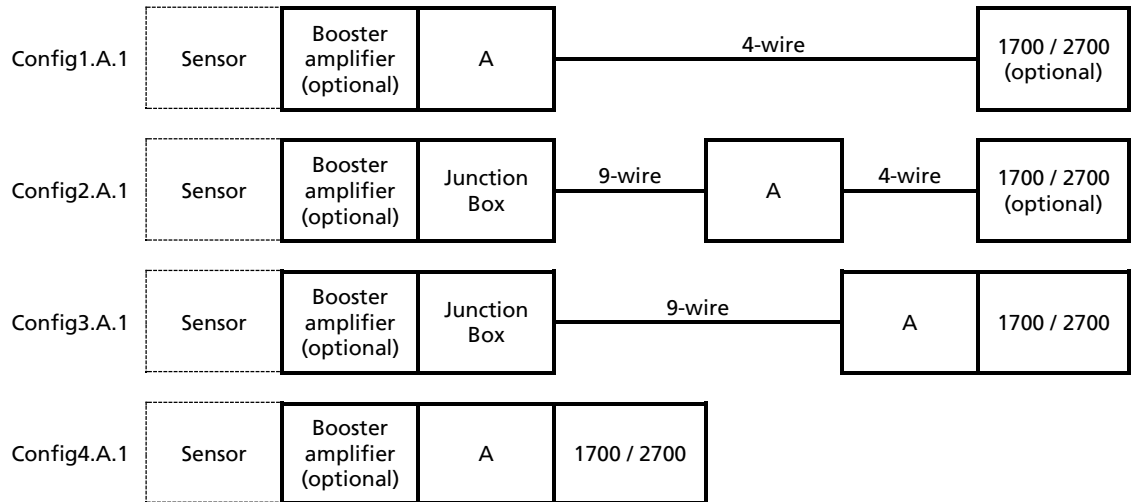

With A indicating the Core Processor (Model 700 or Model 800)

### Transmitter Type a700bcdefghijk

- Pos a: 1 = Single Variable Transmitter (i.e. 1700)  
 2 = Multi Variable Transmitter (i.e. 2700)
- Pos b: Mounting;  
 E = 4-wire remote mount transmitter in alum enclosure with 9-wire remote enhanced core processor (800). Config 2.A.1;  
 F = 4-wire remote mount transmitter in SS enclosure with 9-wire remote enhanced core processor (800). Config 2.A.1;  
 M = 4-wire remote transmitter in SS enclosure. Config 1.A.1;  
 P = 9-wire remote transmitter in SS enclosure. Config 3.A.1;  
 R = 4-wire remote transmitter in alum. enclosure. Config 1.A.1;  
 B = 4-wire remote mount transmitter in alum. enclosure with 9-wire remote core processor (700). Config 2.A.1;  
 C = 9-wire remote transmitter in alum enclosure. Config 3.A.1;  
 I = Integral mounted transmitter Config4.A.1.
- Pos c: Power Supply. Option without influence on custody transfer approval
- Pos d: Display:  
 1, 2, 4 and 5 = with Display;  
 3 = without Display
- Pos e: Output options:  
 A = ANALOG BRD (MVD1700 and MVD2700);  
 B = Config. I/O BRD, factory default setting (MVD2700 only)  
 C = Config. I/O BRD, dedicated to application (MVD2700 only)
- Pos f: Conduit connections: Option without influence on custody transfer approval
- Pos g: Ex-approvals: Option without influence on custody transfer approval
- Pos h: Language: Option without influence on custody transfer approval
- Pos i: Software options 1:  
 Z = Flow & density variables (standard)  
 A = Petroleum measurement (volume conversion) (MVD2700 only)



## Annex 1

Number **TC7057** revision 32  
Project number 1901569  
Page 2 of 4

G = concentration measurement (mass, density or volume conversion) (MVD2700 only).

Note alternatively letter code Z is used with ETO number 09851 and 12767.

- Pos j: Software options 2  
W= Custody Transfer  
D = Custody Transfer and Meter verification (MVD800 only)
- Pos k: Factory options: Option without influence on custody transfer approval

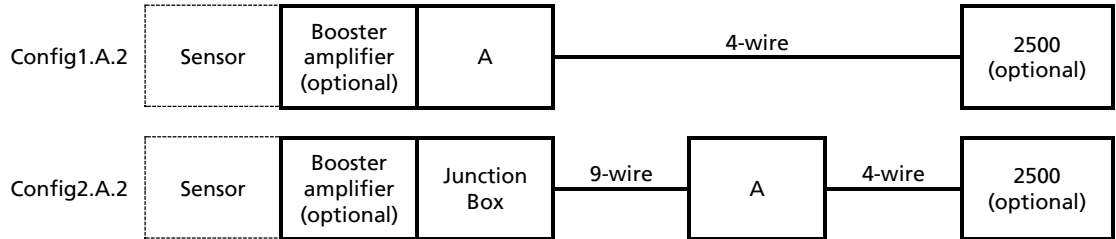

With A indicating the Core Processor (model 700 or Model 800)

### Transmitter Type 2500abcdefghij

- Pos a: Mounting;
  - B = 4-wire remote 35 mm DIN rail transmitter with 9 wire remote core processor (Config2.A.2);
  - D = 4-wire remote 35 mm DIN rail transmitter (Config1.A.2)
- Pos b: Power Supply:
  - 3 = 19.2 to 28.8 V DC
- Pos c: Conduit connections: Option without influence on custody transfer approval
- Pos d: Output options:
  - B = one mA; two configurable I/O channels; RS-485 – default configuration
  - C = one mA; two configurable I/O channels; RS-485 – custom configuration
- Pos e: Terminals: Option without influence on custody transfer approval
- Pos f: Approvals: Option without influence on custody transfer approval
- Pos g: Language: Option without influence on custody transfer approval
- Pos h: Software options 1:
  - Z = Flow & density variables (standard)
  - Note: option A (petroleum measurement (volume conversion)) is not allowed.
- Pos i: Software options 2:
  - W= Custody Transfer
  - D = Custody Transfer and Meter verification (MVD800 only)
- Pos j: Factory options: Option without influence on custody transfer approval

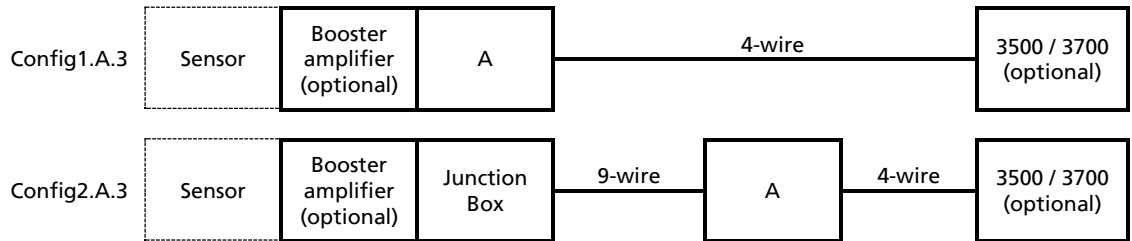

With A indicating the Core Processor (Model 700 or Model 800)

### Transmitter Type 3500bcdefghijklm and Type 3700bcdefghijklm

- Pos b: Mounting options;  
 R = Din-rack mount (3500 only)  
 P = Panel mount (3500 only)  
 A = Field mount (3700 only)
- Pos c: Power Supply. Option without influence on custody transfer approval
- Pos d: Remote Core Processor. Option without influence on custody transfer approval
- Pos e: Additional hardware modules;  
 2 = Weights & Measures Custody Transfer (OIML)  
 3 = Marine Bunker Hardware
- Pos f: Sensor interface:  
 5 = 4-wire interface to sensor with core processor (Config 1.A.3 only)  
 6 = 4-wire remote mount transmitter with 9-wire remote core processor (Config 2.A.3 only)
- Pos g: Terminals. Option without influence on custody transfer approval
- Pos h: Relays and housing:  
 1 = No relays and housing
- Pos i: Approvals. Option without influence on custody transfer approval
- Pos j: Language: Option without influence on custody transfer approval
- Pos k: Control application software: Option without influence on custody transfer approval
- Pos l: Measurement application software.  
 A = Petroleum measurement (volume conversion)  
 B = Concentration measurement predefined  
 G = Concentration measurement  
 Z = No measurement application software
- Pos m: Specialty applications:  
 Z = No specialty applications

#### Approved models code for the 3500 with CIC A2 (serial number ≥ 25000000):

- 3500\*\*\*2 [5 or 6]\*\*\*\*[Z or D][Z, G, B or A]\* with model 700
- 3500\*\*\*2 [5 or 6]\*\*\*\*[Z, C, D or E][Z, G, B or A]\* with model 800
- 3500\*\*\*35\*\*\*\* [F or H]Z\* with model 800

#### Approved models code for the 3700 with CIC A2 (serial number ≥ 25000000):

- 3700\*\*\*2 [5 or 6]\*\*\*[Z or D][Z, G, B or A]\* with model 700
- 3700\*\*\*2 [5 or 6]\*\*\*[Z, C, D or E][Z, G, B or A]\* with model 800
- 3700\*\*\*35\*\*\* [F or H]Z\* with model 800

Manufacturer model identification codes for the approved versions.