

**SPECIAL PURPOSE DIRECTIONAL AND
PRESSURE CONTROL AIR VALVES**
MOBILE, OILFIELD AND MARINE

Pneumatics
It's that easy



Special Purpose Pneumatic Valves

Section 1: SC-700 Pneumatic Directional Control Valves



"A" Pilotair® Valves

These valves are panel mounted, poppet-type valves that open, close and vent an air circuit. They are ideal for frequent use because of ease of operation, fast response and ability to tolerate contaminated air. Maximum pressure is 250 psi, 1.0 C_v, 1/4" NPT ports, with 3-way, 4-way and multiple 3-way functions. Handle operated or block style valves with a variety of air pilot or mechanical operators are available.



"D" Pilotair® Valves

A custom valve for a standard price, the "D" Pilotair is easily tailored to your installation. Nine basic valves and nine basic operators in both 1/4" and 1/2" NPT & BSPP port sizes, along with various operator spring return and holding functions are available. The operators and valve segments can be rotated at 90-degree increments to fit most any application problem, with flows of 2.1 and 5.1 C_v. Engineered for no leakage. Available supported functions are 2-way, 3-way and 4-way. Valves are factory tested for bubble tight sealing.



"P" Rotair® Valves

This valve has a single handle operation, with up to eight distinct handle positions, and is ideal for control of multi-position cylinders on vehicle transmissions. Maximum supply pressure is 150 psi. It supports multiple 3-way functions and has 1/4" NPT ports.

Section 2: SC-800 Pneumatic Pressure Control Valves



"H" Controlair® Valves

Hand, foot or mechanically operated, these valves can control both pressure and flow of air. Some models control functions in separate and independent air circuits or in branches of the same circuit. Other models control these functions either selectively or simultaneously in three separate and independent branches of an air circuit. Outlet pressures are controllable between 0-175 psi and can maintain pressure within 1-1/2" psi.



Flexair® Valves

This valve gives 3-way, precise control of the various functions performed during the operation of oil/gas drilling rigs, excavating machinery, hoists, dredges and production machines. Handle options include various lengths, self-holding, self-returning and detent in extreme positions. Handle guide arrangements available to operate one, two or three pressure or directional control lines separately or in combinations. Maximum pressure is 150 psi.



"M" Plus® Valves

Designed for short distance (up to 50 feet), low-force pressure control applications, this valve offers economical and accurate control. Operators include hand lever, foot pedal and mechanical plunger. Maximum supply pressure is 150 psi, with choice of two controllable output pressure ranges, 0-60 or 0-100 psi. Sensitivity is 2 percent of range, and ports are 1/8" NPT.

Table of Contents for Section I (SC-700) Special Purpose Pneumatic Directional Control Valves

	Page No.
Type "A" Pilotair® Valves—Overview & Specifications	2
Block Style 3-Way Valves	3
2-MA-1A Normally Closed, Mechanical Straight Push	4
2-MA-1A Normally Closed, with Lugs	5
2-CA-1A Normally Closed, with Cam Dog	6
2-CA-1B Normally Open, with Spring Opposed Cam Roller Lever	7
2-CA-1C Normally Closed, with Single Direction Cam Roller	8
2-CA-1A Normally Closed, with Two Direction Cam Roller	9
2-LA-1A Normally Closed, with Palm Lever	10
2-PA-1A Normally Closed, Air Piloted	11
Panel Mounted Valves: 3-Way, 4-Way & Multi-Function	12
2-BA-1, 3-Way Button Operated, Single Unit Valves	13
2-HA-1, 3-Way Handle Operated, Single Unit Valves	14-15
2-HA-2, 4-Way Handle Operated, Double Unit Valves	16
4-Way & Multi-Function Handle Operated, Double Unit Valves	17-18
2-HA-3 & 2-HA-4 Multiple Function Models—Single Handle, Gated	19-22
2-HA-3 & 2-HA-4 Multiple Function Models—Double Handle, Detented	23-24
2-HA-3 & 2-HA-4 Multiple Function Models—Double Handle	25-27
3-Way, Normally Closed Cartridge Valve	29-30
Cartridge Valve Repair Kits	30
Type "D" Pilotair® Valves—Index and Descriptions	31
Features and Specifications	32
Basic Valves	33
Operator Kits	34-36
Valve Functions & Tabulated Model Numbers	37-43
How To Order Valves Not Tabulated	44-46
Repair Kit List	47
Application Circuits	48
Model Code To Part Number Cross References	49-51
Type "P" Rotair® Valves—Features & Description	52-53
Model Description and Part Number List	53
Assembly Views and Repair Recommendations	54
Handle Position Porting Diagrams	55
Outline Dimensions	56-57
Repair Kits	58
SECTION II Catalog SC-800	
Special Purpose Pneumatic Pressure Control Valves	after page 58

"A" Pilotair® Pneumatic Directional Control Valves Features and Specifications

"A" PILOTAIR, Block-type and Panel Mounted Valves

The AVENTICS "A" PILOTAIR Valves are block-type and panel-mounted poppet-type directional valves which open, close or vent an air circuit. The poppet-type directional valve is ideal for frequent usage because of its ease of operation. This valve line makes maximum use of high production parts which are interchangeable throughout this product line as well as providing interchangeability of parts with the poppets in our Controlair® and Flexair® Valve product lines. A definite advantage is gained when all of these products are used in the same application.

A very short travel of the valve parts produces full capacity flow. This factor is important in fact action circuits and repetitive manual or mechanical operations. Its design is highly compact for conserving mounting space and appearance. Spring force and air pressure are combined to give a tight seal and its resulting economies. Both block type and panel mounted "A" PILOTAIR Valves have a large flow capacity and have been proven under the most adverse conditions for dependable operation.

STANDARD SPECIFICATIONS

All Valve Models

MATERIALS - Both the block type and panel-mounted "A" PILOTAIR Valves have die-cast anodized aluminum bodies for corrosion resistance. They use a one piece unitized cartridge valve element that is made of an engineered plastic and stainless steel. The seals are oil resistant, synthetic rubber.

The panel-mounted "A" PILOTAIR contains hardened sintered steel cams and cam followers. The cam shaft is a steel extrusion. The handle shaft is nickel-zinc plated steel.

PRESSURES - Maximum inlet pressure is 250 psi (17.2 bar).

TEMPERATURE - Maximum operating temperature is -40°F to +200°F (-40°C to +93°C)

MEDIA - Air & inert gases (consult factory for other uses).

CAPACITY - As shown by the graph, these valves have been designed to give maximum flow capacity to speed operations and provide full power.

CARTRIDGE VALVE ELEMENT - is constructed of engineered plastic and stainless steel. This design gives superior corrosion resistance and sealing also simplifies repairs. See page 28 for complete details.

APPROXIMATE WEIGHTS

"A" PILOTAIR Valve, Block Type

2-MA-1A	1/2 lb. (0.23 Kg)
2-LA-1A	3/4 lb. (0.34 Kg)
2-CA-1A	3/4 lb. (0.34 Kg)
2-CA-1B	1 lb. (0.45 Kg)

"A" PILOTAIR Valve, Panel Mounted

2-BA-1	1 lb. (0.45 Kg)
2-HA-1	1-1/2 lb. (0.68 Kg)
2-HA-2	2 lb. (0.91 Kg)
2-HA-3	4 lb. (1.81 Kg)
2-HA-4	4 lb. (1.81 Kg)

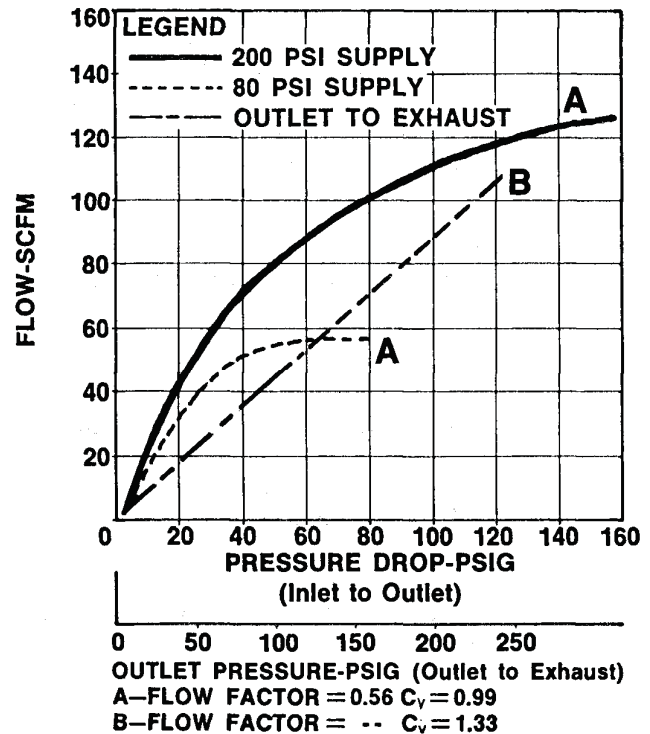

To determine flow from inlet to outlet for any pressure drop with 80 psi (5.5 bar) supply pressure, project up from the PRESSURE DROP Scale (permissible difference between inlet and outlet pressures) to the dotted curve.

At this intersection, project to the left for the resulting flow on the vertical scale. For 200 psi (13.8 bar) use the solid curve. To determine flow from outlet to exhaust, project from OUTLET PRESSURE Scale to the dash line curve and then to the left.

**“A” Pilotair[®] Pneumatic Directional Control Valves
Block-Type Valves-Three Way**

The Block-Type “A” PILOTAIR Valve is a poppet-type, on-off, 3 way directional valve enclosed in a solid die-cast aluminum block for ruggedness and ease of installation. The basic valve and all operators can be easily and quickly assembled without special tools. This valve line features a choice of six operators, assembled to the basic valve 2-MA-1A, to provide cam, lever and pilot cylinder operation. The design permits conversion from one type of operation to another and simplifies stocking. The body design lends itself to individual or multiple-mounting operations. The Block-Type “A” PILOTAIR Valve can be installed in any convenient position without interfering with the valve operation. The straight, flat sides are identical to provide either

right or left hand horizontal mounting. Mounting holes are also provided for mounting the valve vertically from the top or bottom. All valves, except the Normally Open 2-CA-1B, have dual 1/4” NPT IN and OUT ports for ease of piping. Pipe plugs are furnished with each valve for plugging the unused ports.

Unitized cartridge valve elements are used for long life, easy service, corrosion resistance and excellent sealing characteristics.

2-MA-1A

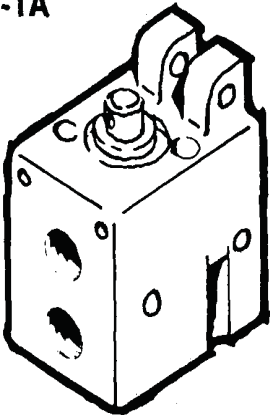

without lugs, N.C., page 4
with lugs, N.C., page 5

2-CA-1A

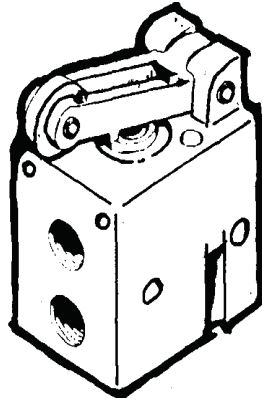

cam dog, N.C. operator, page 6
cam roller operator kit, page 9

2-CA-1B

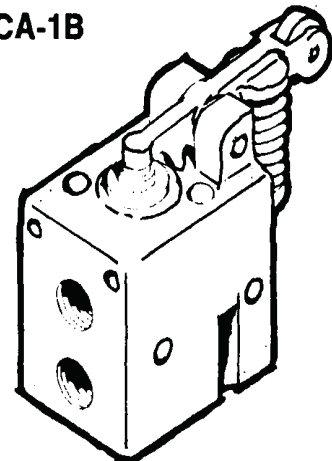

cam roller, N.O. operator, page 7

2-CA-1C

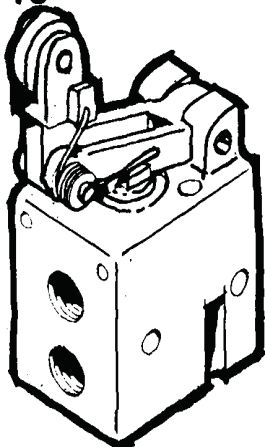

single direction cam roller,
N.C. operator, page 8
two direction cam roller, N.C.
operator (2-CA-1A), page 9

2-LA-1A

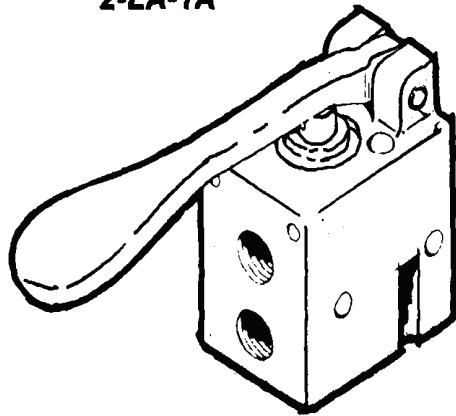

palm lever, N.C. operator, page 10

2-PA-1A

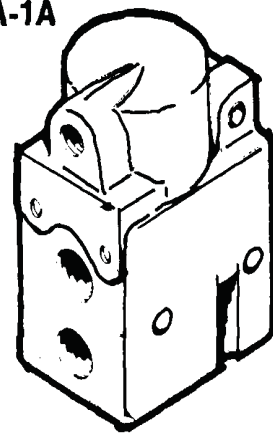

air pilot, N.C. operator, page 11

**“A” Pilotair® Pneumatic Directional Control Valves
Block-Type Valves Three Way - Normally Closed**

OPERATION

In release position, as shown, the valve disc seats on the inlet valve seat and seals the passage from the inlet to the outlet port. The outlet port is vented to atmosphere through the center of the plunger. As the plunger is forced downward by an external force it seats on the valve disc. This seals the passage between the outlet port and atmosphere. Future downward travel of the plunger unseats the valve disc from the inlet valve seat and allows inlet air pressure to flow to the outlet port. Release of the external force releases the plunger, and valve and plunger return to the original position.

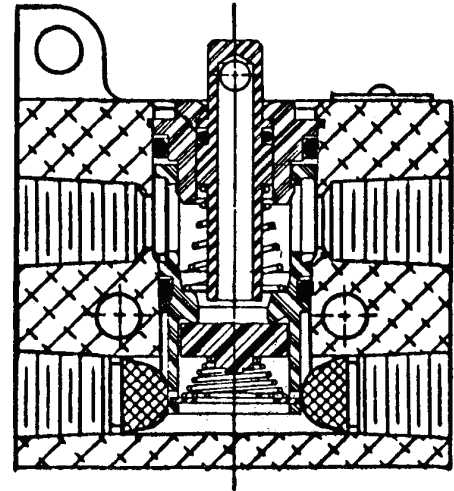

Install the valve to ensure operation within the travel limits shown on the outline drawings. Travel beyond these limits can cause damage to the valve.

**2-MA-1 PILOTAIR VALVE
NORMALLY CLOSED**

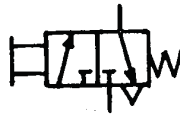

The 2-MA-1A PILOTAIR valve is a mechanically (straight push) operated, 3-way directional valve with a variety of mounting styles. The outlet port is exhausted in release position. This valve is the basic valve shown below, without lugs.

.26 DIA. MOUNTING HOLES
(2 PLACES)

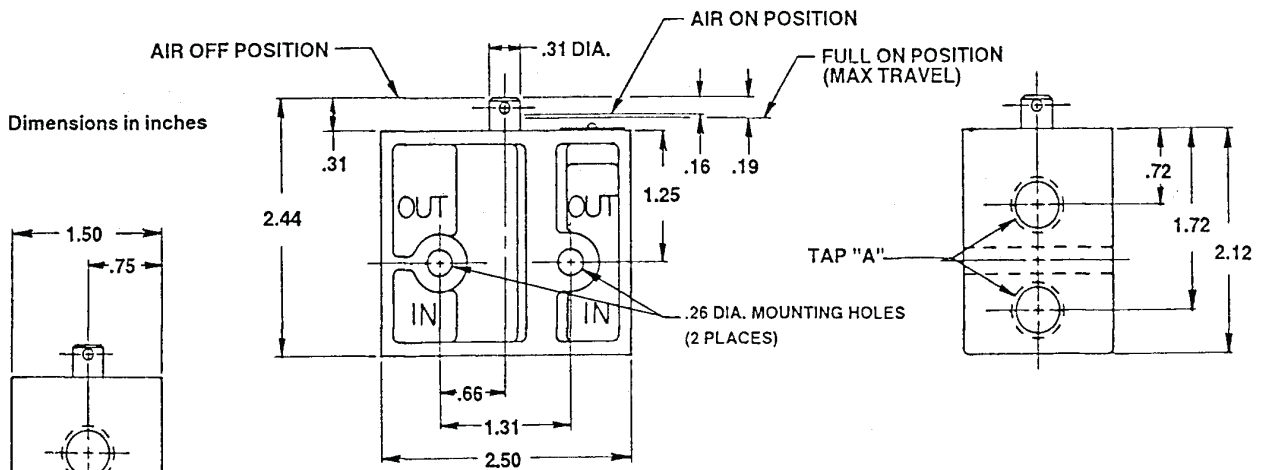
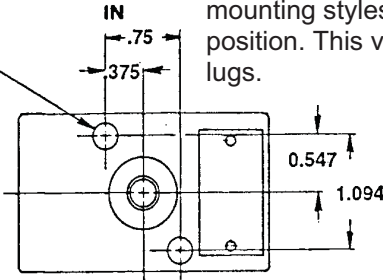

BOTH SIDES ARE IDENTICAL FOR
RIGHT OR LEFT HAND MOUNTING

ORDERING REFERENCE

2-MA-1A PILOTAIR Valve (Less Lugs) for direct push operation.
Part Number R431004659
(Old P/N P -058718-00000)

**“A” Pilotair[®] Pneumatic Directional Control Valves
Block-Type Valves Three Way-Normally Closed**

**2-MA-1A PILOTAIR VALVE,
NORMALLY CLOSED**

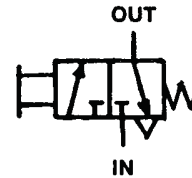

The 2-MA-1A valve, with lugs, is the basic block-type “A” PILOTAIR Valve. It may be combined with the operator kits listed on the following pages to provide palm lever, pilot cylinder, cam dog and cam roller operation. Operator kits contain all material required to adapt each of these operators to the basic valve.

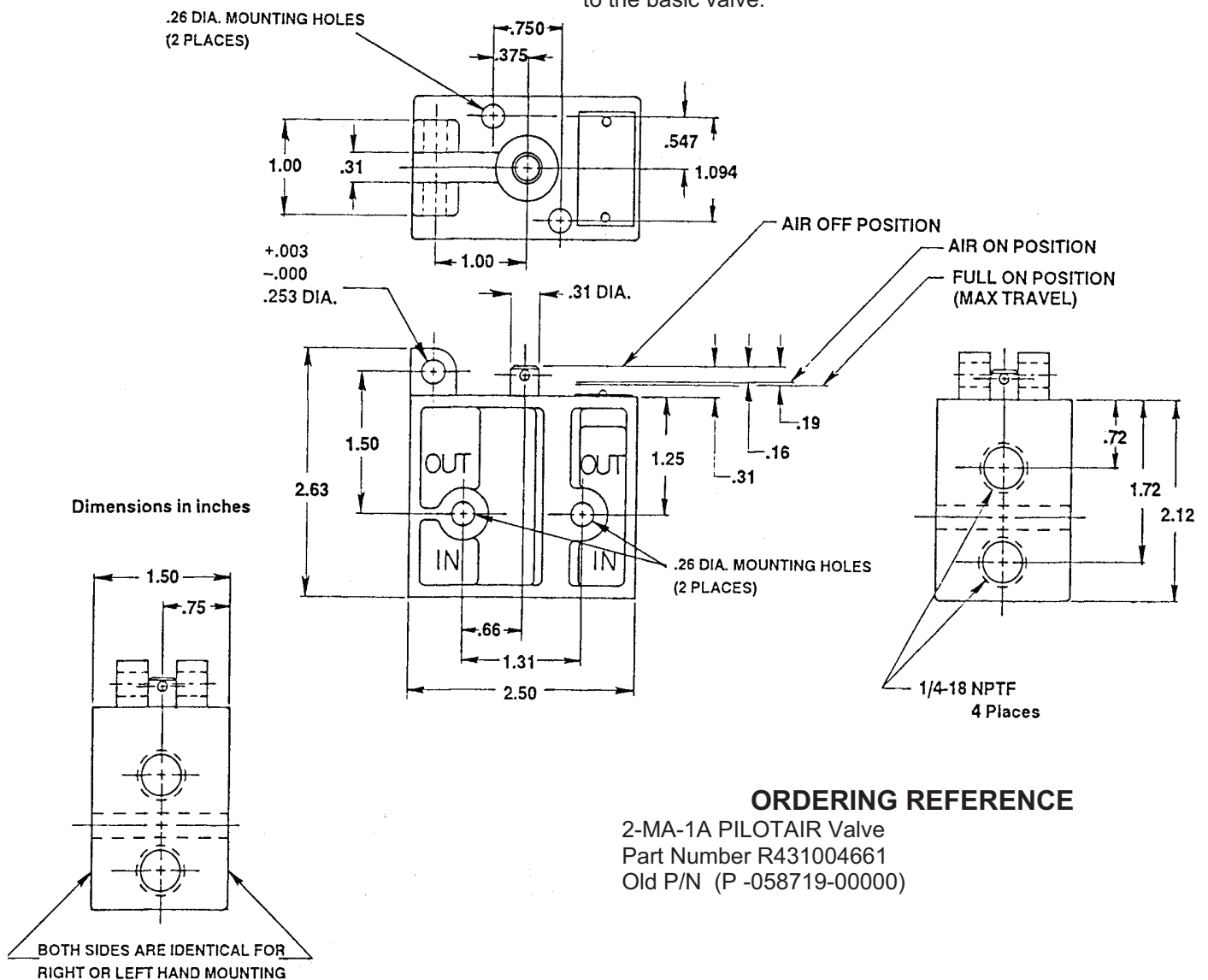

**“A” Pilotair® Pneumatic Directional Control Valves
Block-Type Valves Three Way-Normally Closed**

**2-CA-1A PILOTAIR VALVE WITH CAM DOG,
NORMALLY CLOSED**

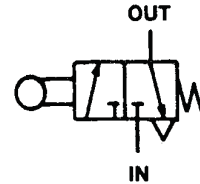

The cam dog operated 2-CA-1A PILOTAIR Valve is composed of the 2-MA-1A PILOTAIR Valve and the Cam Dog Operator Kit.

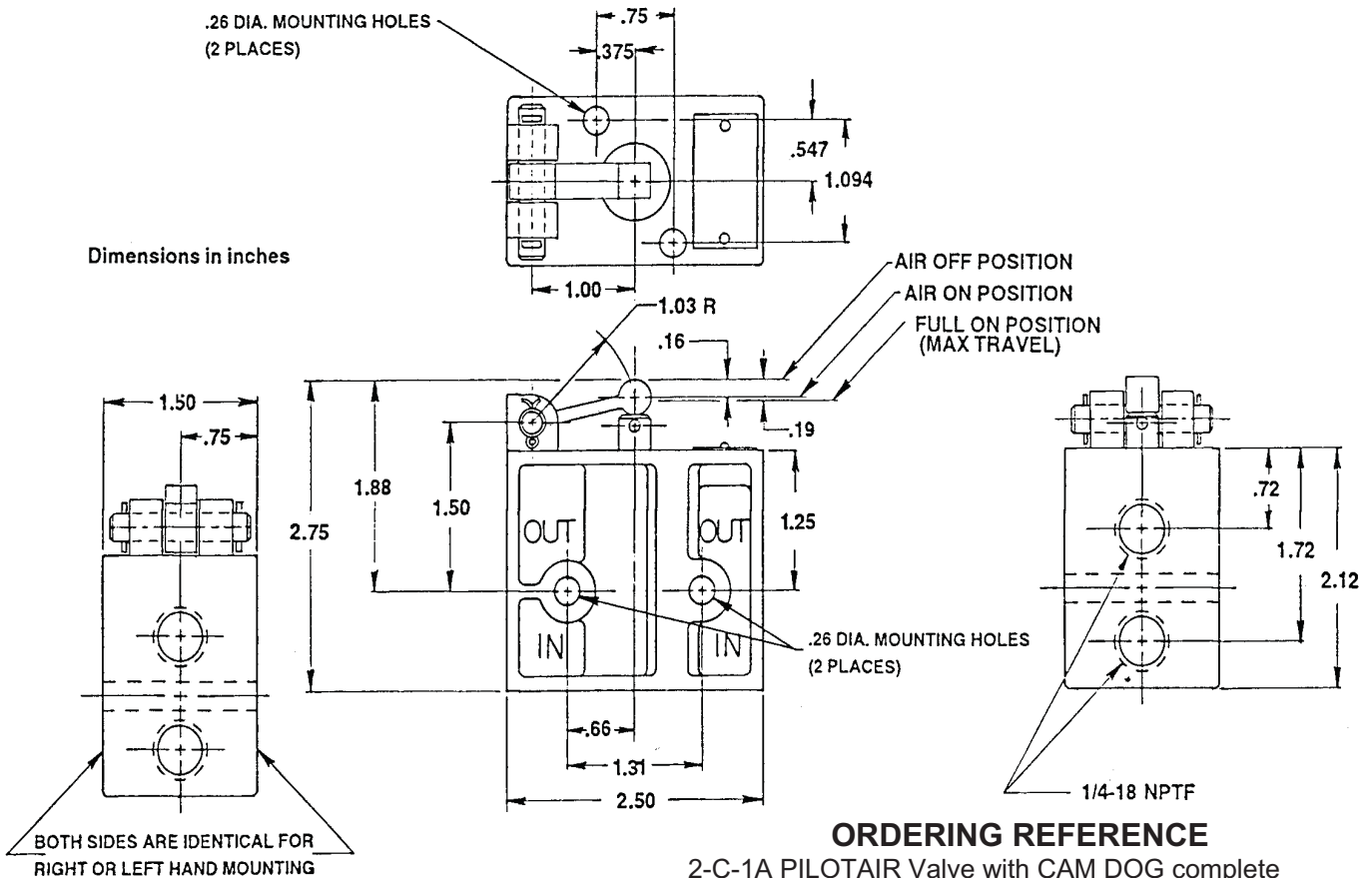

ORDERING REFERENCE

2-C-1A PILOTAIR Valve with CAM DOG complete
Part Number R-431004665
(Old P/N P -058720-00000)

CAM DOG OPERATOR KIT

Contains a hardened, stainless steel cam dog, cam dog pin and cotter.
Part Number R431003068
(Old P/N P -052973-K0000)

“A” Pilotair[®] Pneumatic Directional Control Valves
Block Type Valves Three Way-Normally Open

**2-CA-1B PILOTAIR VALVE,
 WITH SPRING OPPOSED
 CAM ROLLER LEVER,
 NORMALLY OPEN**

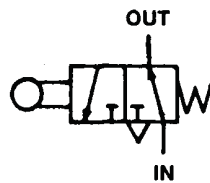

This 3-way directional valve has the inlet port connected to the outlet port in its normal position. When a cam operates the spring opposed cam roller lever, the valve closes and the outlet port is connected to atmosphere.

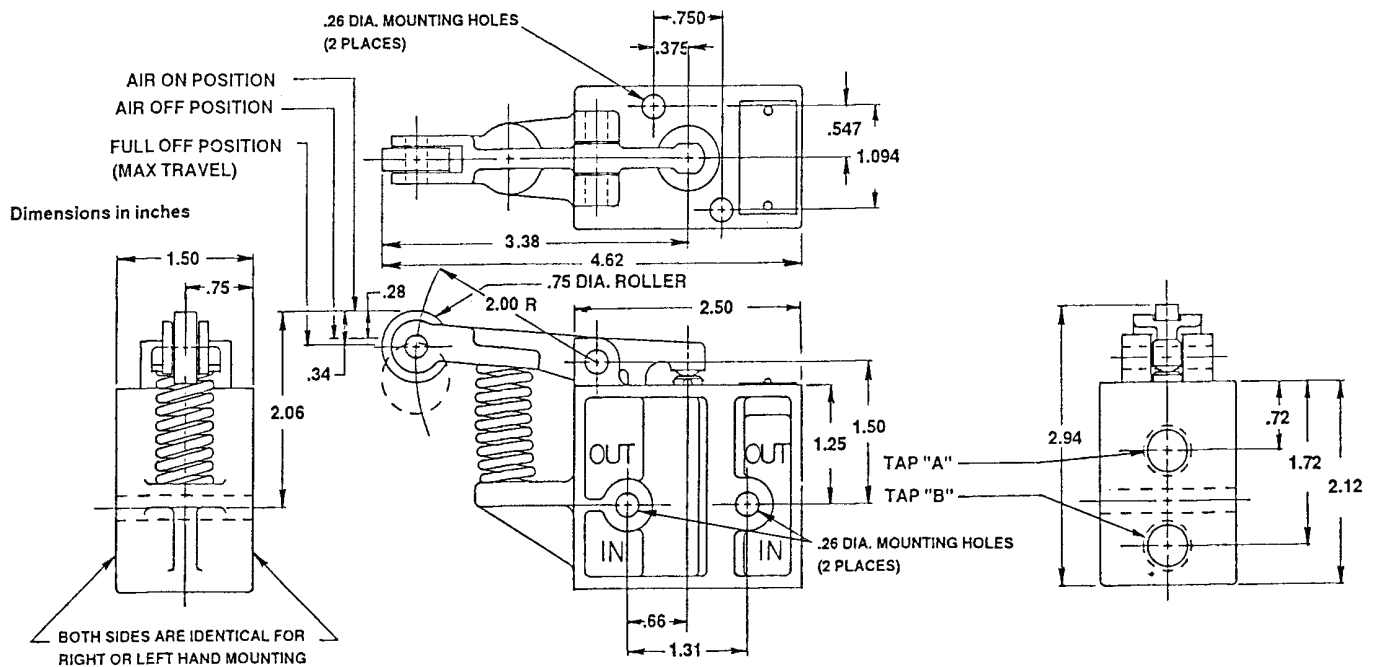

ORDERING REFERENCE

Part No. R431004669 (Old P- 058722-00000) max. inlet pressure 250 psi (17.2 bar). operator force 30 lb.)

Part No. R431004671 (Old P -058722-00002) max. inlet pressure 250 psi (17.2bar). operator force 40 lb.)

Part No. R431004672 (Old P -058722-00003) max. inlet pressure 125 psi (8.6 bar). operator force 14 lb.)

Part No. R431004673 (Old P -058722-00005) max. inlet pressure 250 psi (17.2 bar). operator force 30 lb.)
 w/o Roller

Part No. P -058722-0000 (Max. inlet pressure 125 psi (8.6 bar) operator force 40 lb.)

"A" Pilotair® Pneumatic Directional Control Valves
Block-Type Valves Three Way - Normally Closed

2-CA-1C PILOTAIR VALVE WITH SINGLE DIRECTION CAM ROLLER, NORMALLY CLOSED

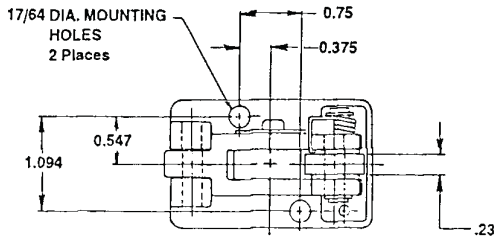
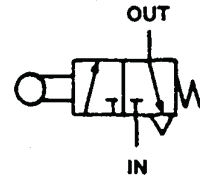

Dimensions in inches

The Single-Direction Cam Roller Operator Kit assembled to the 2-MA-1A PILOTAIR Valve is designated the 2-CA-1C PILOTAIR Valve with Single-Direction Cam Roller.

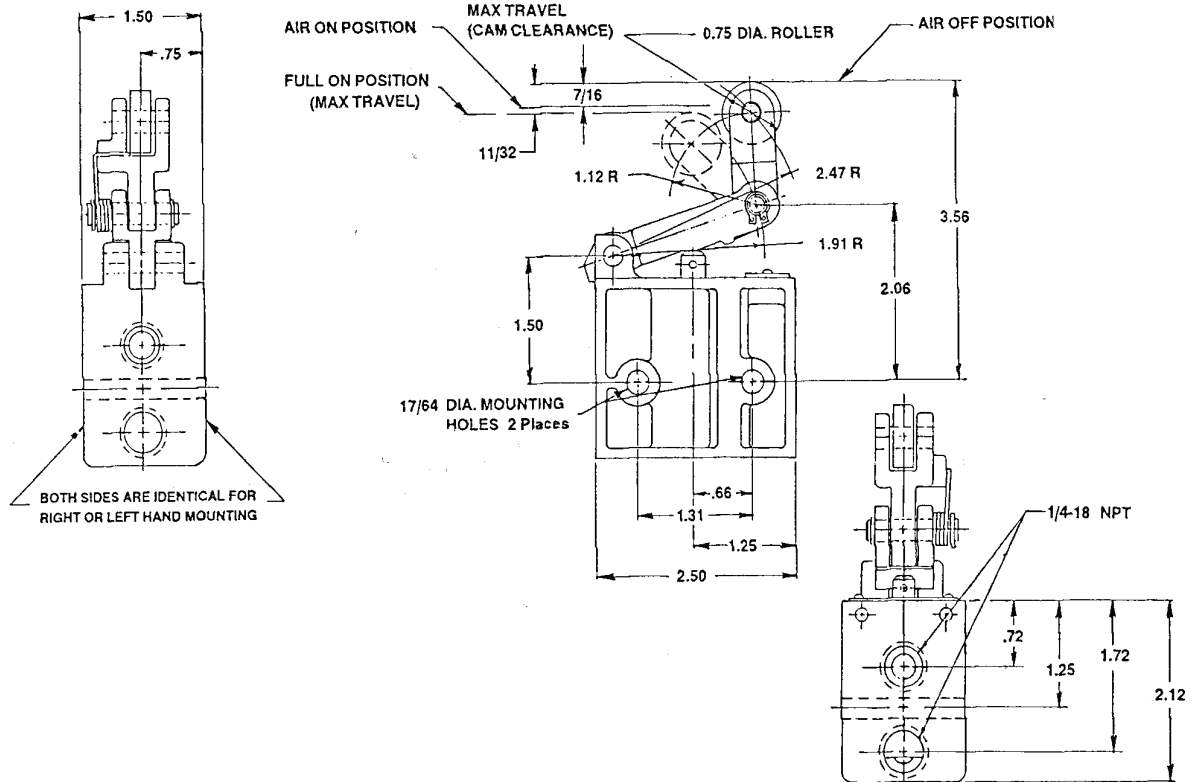

ORDERING REFERENCE

2-CA-1C PILOTAIR Valve, with Single-Direction Cam Roller complete.
 Part Number R431005758 (Old P/N P -061347-00000)

SINGLE-DIRECTION CAM ROLLER OPERATOR KIT

Contains two cam levers, a roller, three roll pins, 2 retaining rings, one torsion spring, and one washer.
 Part Number R431009301 (Old P/N P -061348-K0000)

**“A” Pilotair[®] Pneumatic Directional Control Valves
Block-Type Valves Three Way - Normally Closed**

2-CA-1A PILOTAIR VALVE WITH TWO-DIRECTION CAM ROLLER OPERATOR, NORMALLY CLOSED

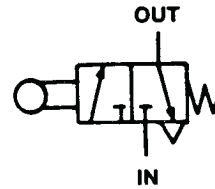

The Two-Direction Cam Roller Operator Kit assembled to the 2-MA-1A PILOTAIR Valve is designated the 2-CA-1A PILOTAIR Valve with Two-Direction Cam Roller.

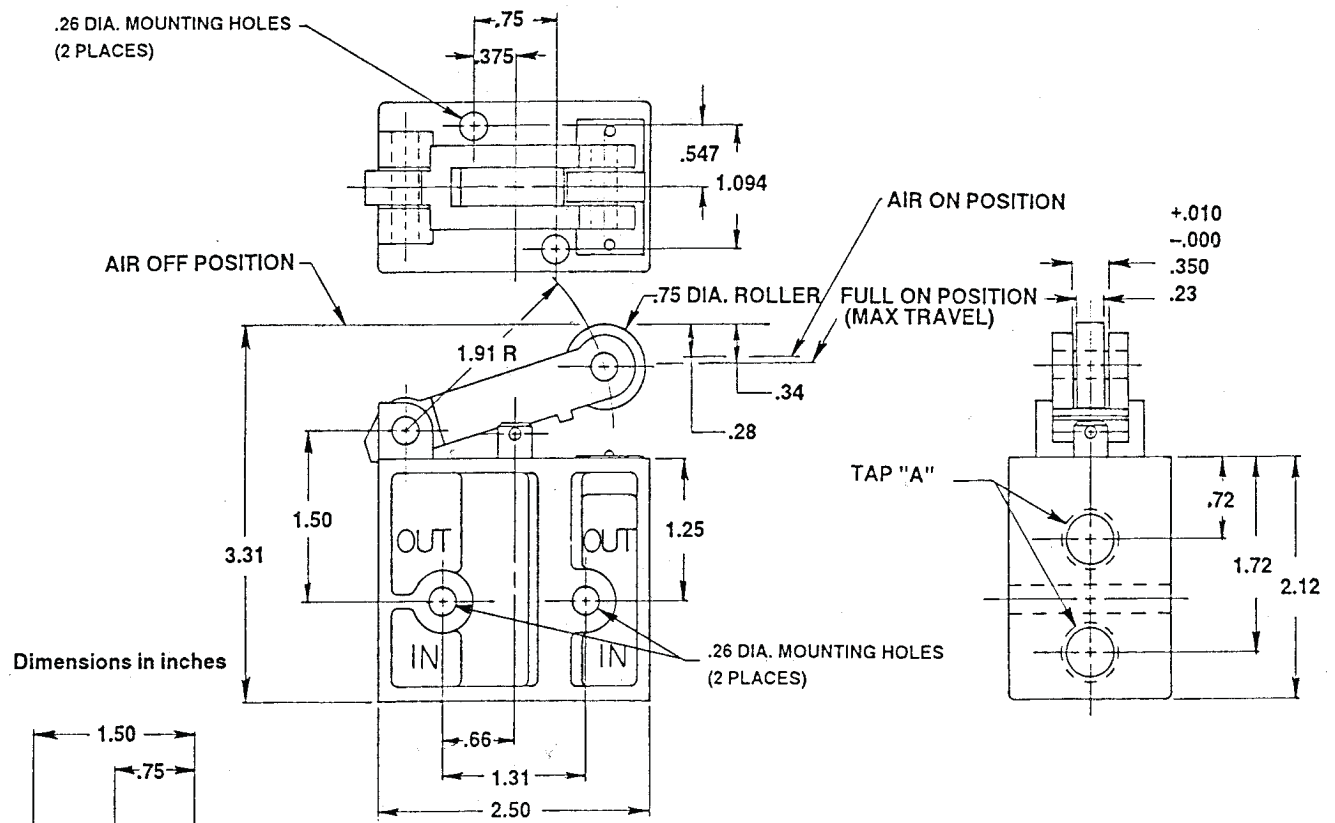

Dimensions in inches

ORDERING REFERENCE

- 2-CA-1A PILOTAIR Valve, with Two Direction Cam Roller complete.
Part Number R431004666 (Old P/N P -058721-00000)
- Part Number R431004668 (less roller only) (Old P/N P -058721-00002)

CAM ROLLER OPERATOR KIT

- Contains a cam lever, a roller, two roll pins and 2 washers.
Part Number R431003071 (Old P/N P -052974-K0000)

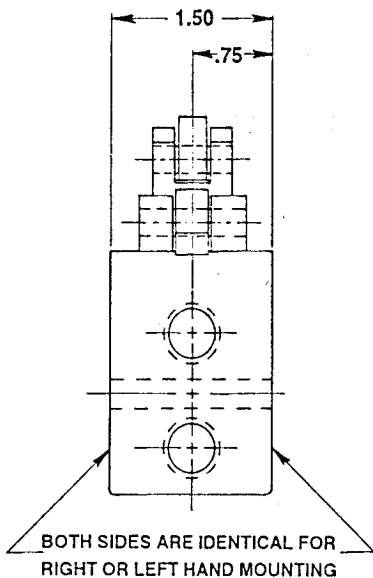

**“A” Pilotair® Pneumatic Directional Control Valves
Block Type Valves Three Way - Normally Closed**

**2-LA-1A PILOTAIR VALVE, PALM LEVER,
NORMALLY CLOSED**

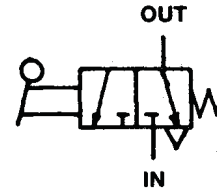

The Palm Lever Operator Kit assembled to the 2-MA-1A PILOTAIR Valve makes the 2-LA-1A PILOTAIR Valve.

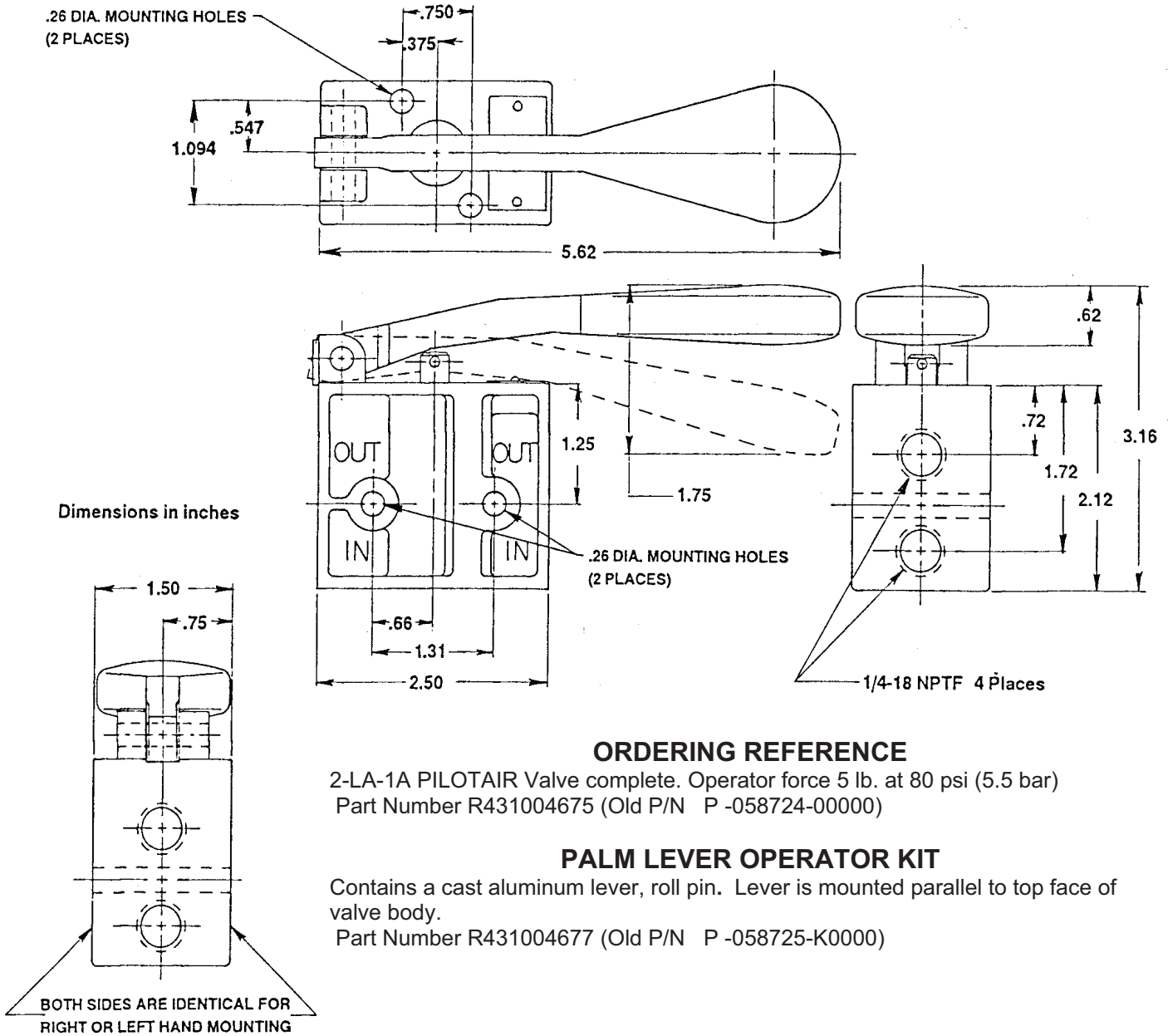

**“A” Pilotair[®] Pneumatic Directional Control Valves
Block-Type Valves Three Way - Normally Closed**

**2-PA-1A PILOTAIR VALVE, AIR
PILOTED, NORMALLY CLOSED**

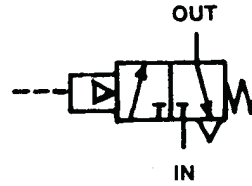

The air pilot operated 2-PA-1A PILOTAIR Valve consists of the Pilot Cylinder Operator Kit assembled to the 2-MA-1A PILOTAIR Valve. Suitable for pilot pressures from 10 to 250 psi (0.7 to 17.2 bar). For each 50 psi (3.4 bar) of inlet pressure, the control pressure must increase 8 psi (0.6 bar). Starting with zero inlet pressure, control pressure must be 10 psi (0.7 bar).

Dimensions in inches

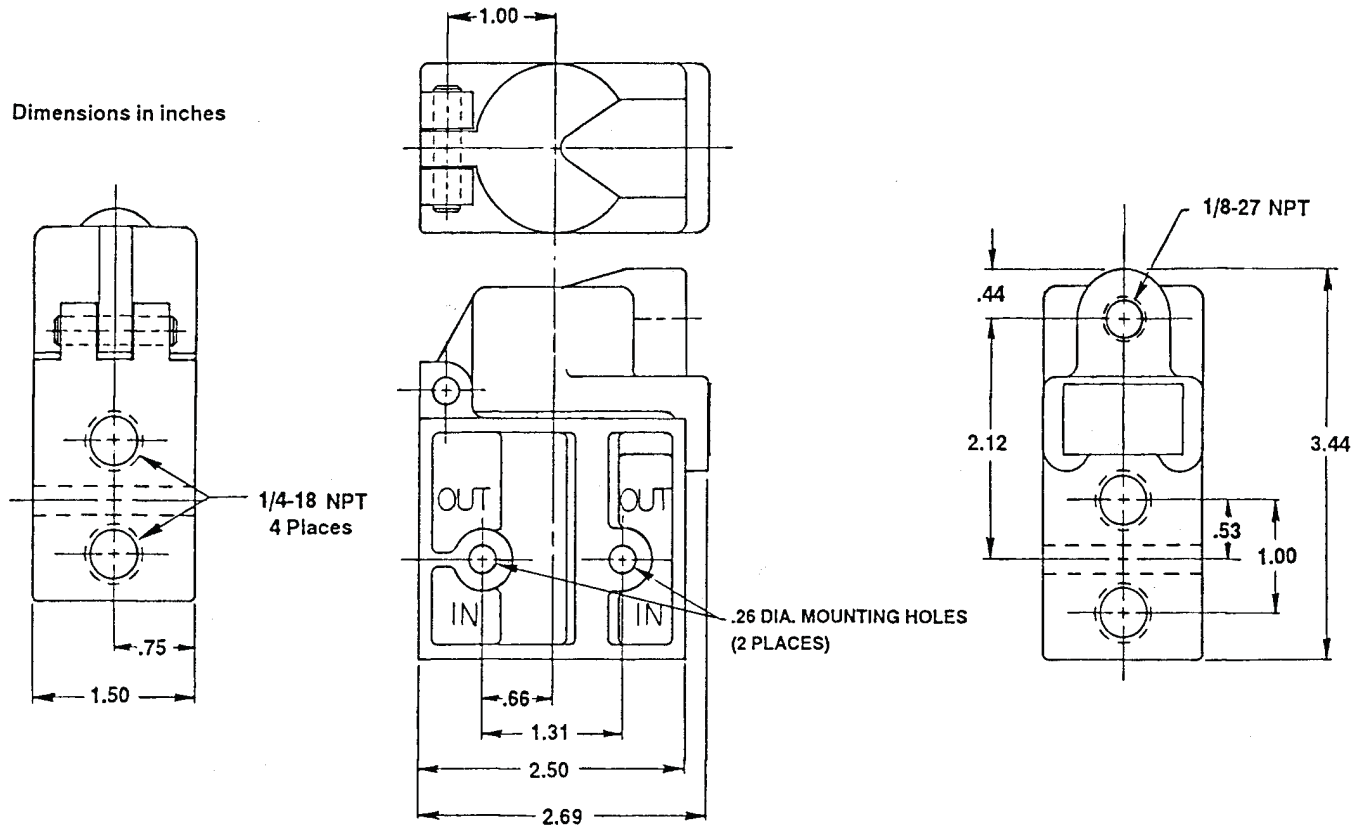

ORDERING REFERENCE

2-PA-1A PILOTAIR Valve complete
Part Number R431004674 (Old P/N P -058723-00000)

PILOT CYLINDER, OPERATOR KIT

Contains a cast aluminum pilot cylinder, piston, “O” Ring packing, roll pin and two DRIV-LOK Pins.
Part Number R431003054 (Old P/N P -052956-K0001)

**“A” Pilotair[®] Pneumatic Directional Control Valves
Panel-Mounted Valves, Three-Way, Four-Way and Multi-Function Operations**

The Panel-Mounted “A” PILOTAIR Valve is a poppet-type pneumatic directional control valve consisting of a cam housing portion and a valve portion containing from one to four 3-way valve units.

The “A” PILOTAIR Valves’ streamlined compact design makes them especially suited for deluxe panel mountings such as in consoles or control panels. They can be mounted in either horizontal or vertical panels. The internal parts are enclosed to make them ideal for outdoor installations or other unfavorable working conditions.

OPERATING VERSATILITY

Versatility has been designed into the operating cams. By reversing, rotating and rearranging these all-purpose cams, all the listed combinations can be made with a minimum of parts. Single unit valves for 3-way operation may be normally open or normally closed. The two unit valves have two, three, or five positions of operation as do the three and four unit valves. (See operation.) Detents can be had for two, three or five positions, or handle may be spring-returned to center for three position operation.

DESIGN FEATURES

Several features have been designed into the Panel-Mounted “A” PILOTAIR Valve for added strength, easier maintenance and longer service life.

- One-piece solid steel shaft for increased strength.
- Bronze bearings in cam housing for longer wear.
- Separate steel handle and hub for increased strength.
- Tooth-type Nylatron plastic detents for longer wear and more positive detenting.
- Internal centering spring assembly for longer wear and more positive handle centering.
- Die-cast anodized aluminum body and cam housing for lighter weight, added strength and corrosion-resistance.
- Handle latch - available in one, two, and three positions for added flexibility and longer service lift.
- Unitized cartridge valve elements are used for long life, easy servicing, corrosion-resistance and excellent sealing characteristics.

2-BA-1

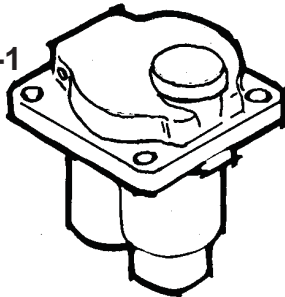

page 13

2-HA-1

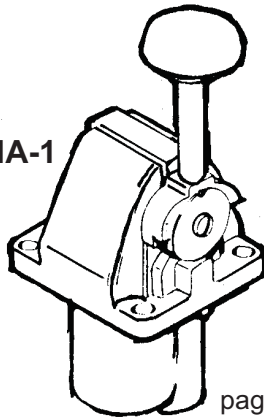

pages 14 - 15

2-HA-2

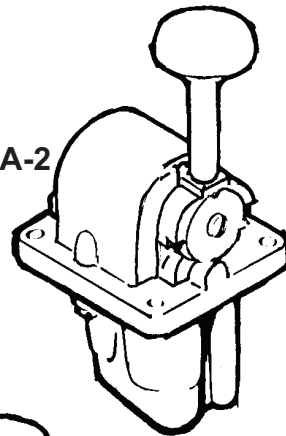

pages 16 - 18

2-HA-3 SINGLE HANDLE
2-HA-4

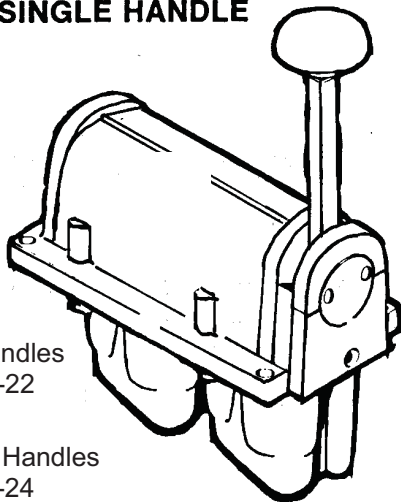

Gated Handles
pages 19-22

Detented Handles
pages 23-24

2-HA-3 DOUBLE HANDLE
2-HA-4

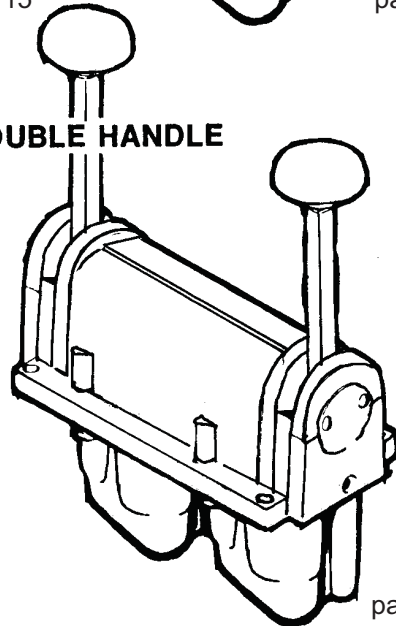

pages 25—27

**“A” Pilotair[®] Pneumatic Directional Control Valves
Panel-Mounted Valves, Three-Way Operation**

OPERATION

In release position, as shown, the valve disc seats on the inlet valve seat and seals the passage from the inlet to the outlet port. The outlet port is vented to atmosphere through the center of the plunger.

As the plunger is forced downward by the cam force it seats on the valve disc. This seals the passage between the outlet port and atmosphere.

Further downward travel of the plunger unseats the valve disc from the inlet valve seat and allows inlet air pressure to flow to the outlet port.

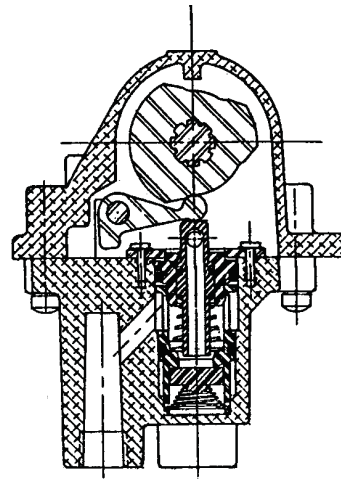

THREE-WAY OPERATION - SINGLE UNIT VALVES

**2-BA-1 PILOTAIR VALVE,
NORMALLY CLOSED**

The model 2-BA-1 PILOTAIR Valve is a panel mounted, 2 position button operated 3-way valve with 1/4" NPT inlet and outlet ports.

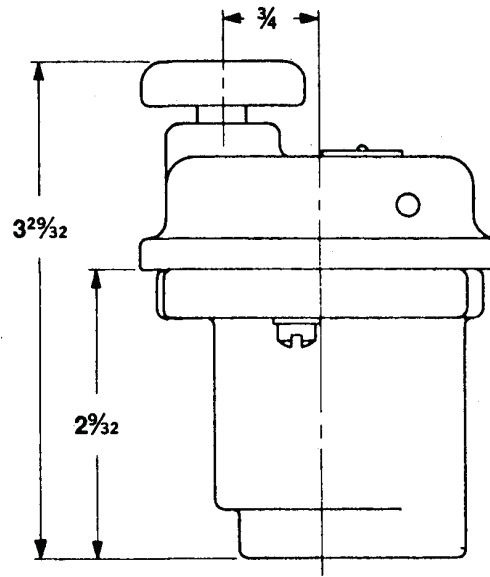
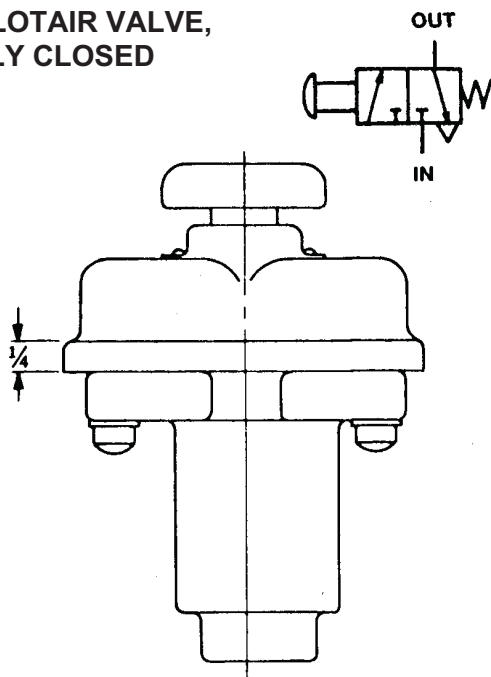

ORDERING REFERENCE

- 2-BA-1 PILOTAIR Valve - Part Number R431003427
(Old P/N P -054692-00002)
- With chrome plated cover - Part No. R431003429
(Old P/N P -054692-00004)
- With special black coated cover - Pt. No. R431003430
(Old P/N P -054692-00006)

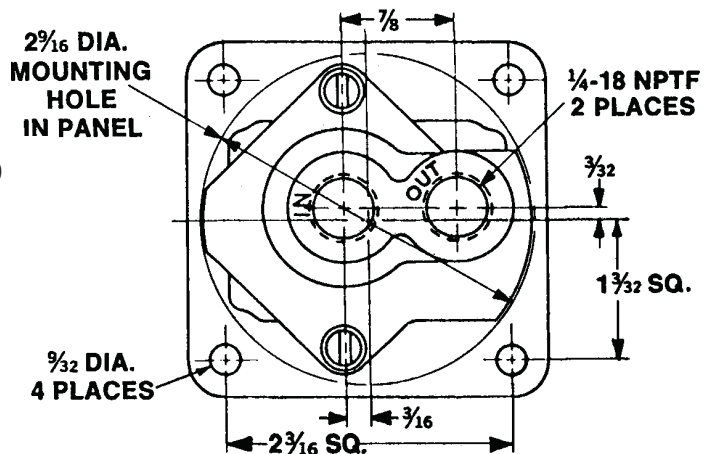

BUTTON POSITION	PORT SUPPLIED
UP	
DOWN	X

“A” Pilotair® Pneumatic Directional Control Valves
Panel-Mounted Valves, Three-Way Operation—Single Unit Valves

2-HA-1 PILOTAIR VALVE

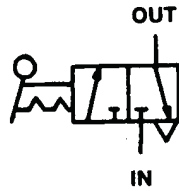

The model 2-HA-1 “A” PILOTAIR Valve is a panel mounted, handle operated 3-way valve with 1/4” NPT inlet and outlet ports. It contains a spring opposed detent cam to hold the handle in either of its two extreme positions. The 2-HA-1L model is available with an

additional external handle latch which requires manual release to insure against unintentional operation. The 2-HA-1W model is spring returned from position 2 to center position, which is the same as position 1 (normally closed).

The model 2-HA-1R, 2-HA-1LR and 2-HA-1RW “A” PILOTAIR Valves are the same as the 2-HA-1 and 2-HA-1L models except that the cam is reversed to obtain pull instead of push operation. The 2-HA-1R model may also be mounted with the handle on the left hand side for tandem push operation with the 2-HA-1 model.

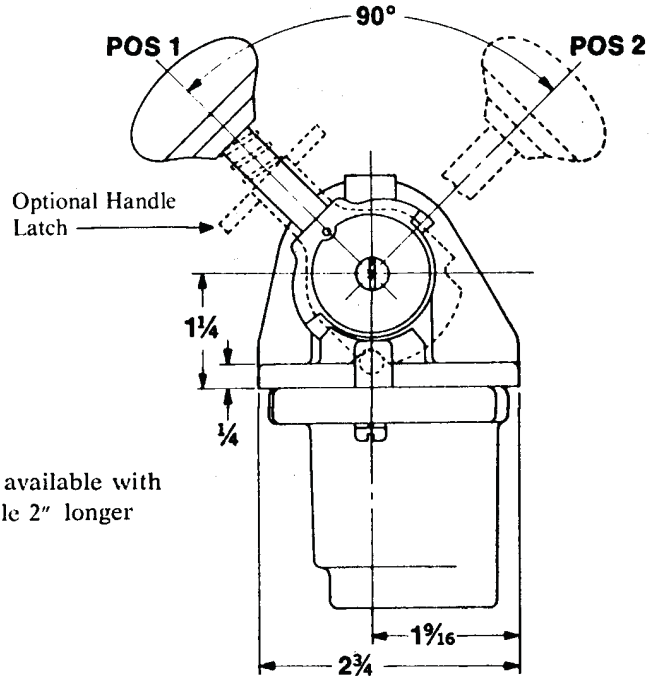
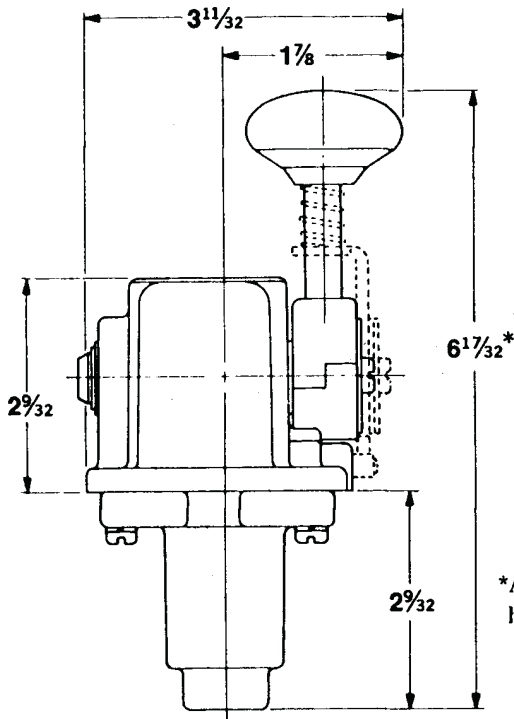

*Also available with handle 2" longer

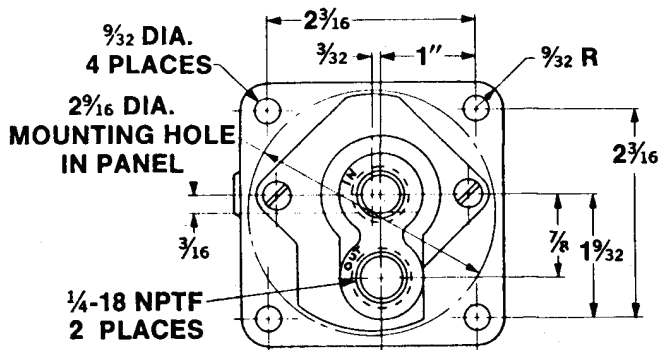

See ordering references on next page

**“A” Pilotair[®] Pneumatic Directional Control Valves
Panel-Mounted Valves, Three-Way Operation—Single Unit Valves**

**2-HA-1 PILOTAIR VALVES
ORDERING REFERENCE**

2-HA-1 PILOTAIR Valve (with detents)

Part Number R431004994
(Old P/N P -059331-00000)
with chrome plated cover and hub
Part Number R431004996
(Old P/N P -059331-00002)
with long handle
Part Number R431006456
(Old P/N P -064533-00000)

2-HA-1L PILOTAIR Valve (with latch)

Part Number R431004997
(Old P/N P -059332-00001)
with chrome plated cover and hub
Part Number R431004999
(Old P/N P -059332-00003)
with black coated cover and hub
Part Number R431004998
(Old P/N P -059332-00002)

Handle Position	Out Port Supplied
1	
2	X

2-HA-1R PILOTAIR Valve (with detents)

Part Number R431005000
(Old P/N P -059333-00000)
with black coated cover and hub:
Part Number R431006571
(Old P/N P -065207-00000)

2-HA-1LR PILOTAIR Valve (with latch)

Part Number R431005001
(Old P/N P -059334-00001)
with chrome plated cover and hub:
Part Number R431005002
(Old P/N P -059334-00003)

Handle Position	Out Port Supplied
1	X
2	

2-HA-1W PILOTAIR Valve

(spring returned to center position)
Part Number R431005660
(Old P/N P -061083-00000)
Maximum inlet pressure 150 psi (10.3 bar)

Handle Position	Out Port Supplied
1	
Center	
2	X

2-HA-1RW PILOTAIR Valve

(spring returned to center position)
Part Number R431005661
(Old P/N P -061090-00000)
Maximum inlet pressure 150 psi (10.3 bar)

Handle Position	Out Port Supplied
1	X
Center	
2	

X denotes port supplied in that position.
Empty block denotes port exhausted in that position.

“A” Pilotair® Pneumatic Directional Control Valves
Panel-Mounted Valves - Four-Way Operation - Double Unit Valves

2-HA-2Y PILOTAIR VALVES
FOUR-WAY, TWO POSITION HANDLE

The 2-HA-2 PILOTAIR Valves are panel-mounted, 2, 3 and 5 position valves with one inlet and two outlet ports. Available with detents in each handle position, a latching handle that requires manual release to insure against unintentional operation*, or spring return to center position. All ports are 1/4" NPT.

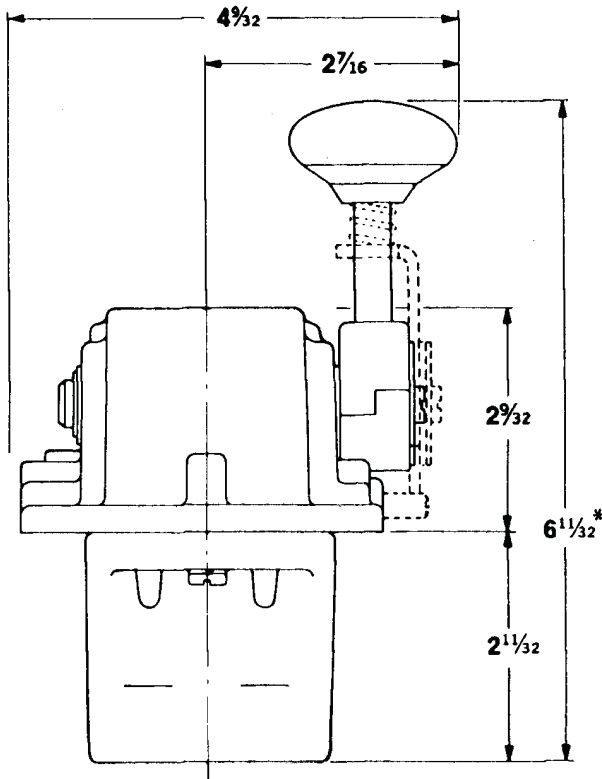

*Also available with handle 2" longer

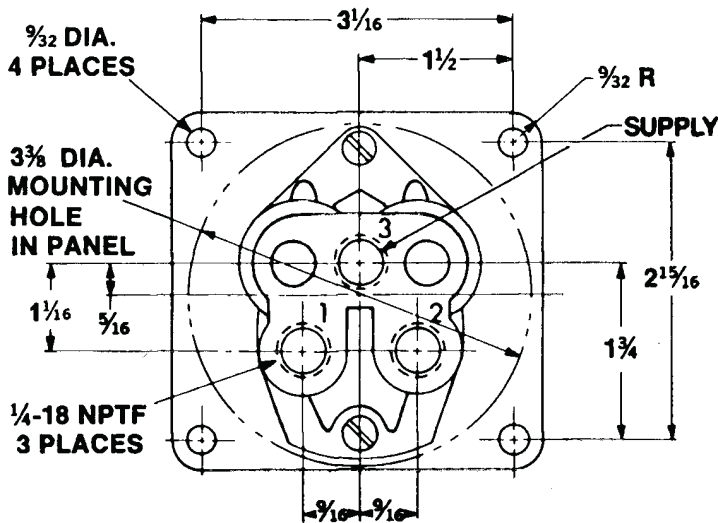
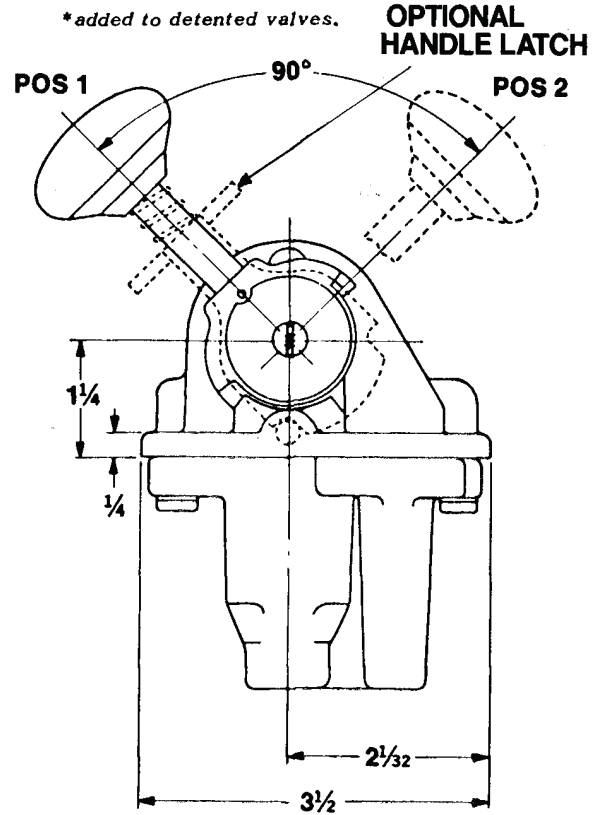

ORDERING REFERENCE (4-Way - 2 Position Handle)

- 2-HA-2Y PILOTAIR Valve** (with detents)
 (supplied thru center) Part Number R431005016
 (Old P/N P -059340-00000)
 with seals for 65°F (-54°C) Part Number R431005017
 (Old P/N P -059340-00001)
 with chrome plated cover & hub Part Number R431005018
 (Old P/N P -059340-00003)
 with long handle Part Number P -065760-00000
- 2-HA-2Y PILOTAIR Valve** (with detents) (exhaust thru center)
 Part Number R431005861 (Old P/N P -061745-00000)
- 2-HA-2LY PILOTAIR Valve** (with latch 1 & 2) (supplied thru center)
 Part Number R431005019 (Old P/N P -059341-00001)
- 2-HA-2LY PILOTAIR Valve** (with latch 1 & 2) (exhausted thru center)
 Part Number R431006194 (Old P/N P -063158-00000)
 with chrome plated cover and hub Part Number R431006195
 (Old P/N P -063158-00002)
 with black epoxy coated cover on hub Part No.R431006604
 (Old P/N P -065353-00000)

Handle Position	Ports Supplied	
	Out 1	Out 2
1		X
2	X	

“A” Pilotair[®] Pneumatic Directional Control Valves
Panel-Mounted Valves, Four-Way and Multi-Function Operation - Double Unit Valves

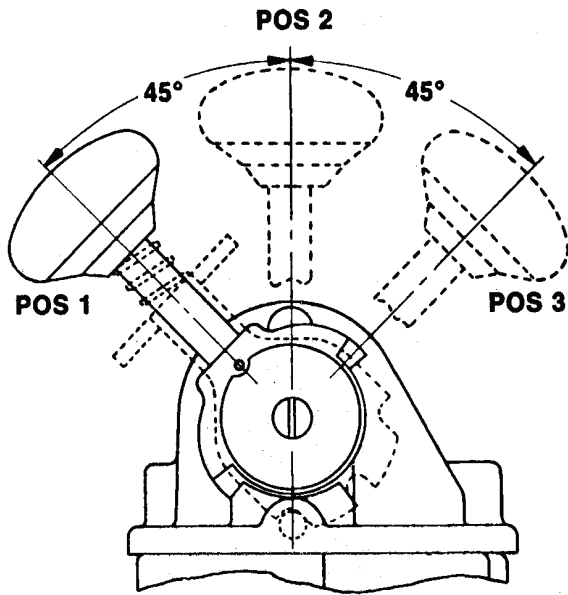

DOUBLE 3-WAY VALVES - 3 POSITION HANDLE

2-HA-2X PILOTAIR Valve (with detents 1, 2 & 3)
 Part Number R431005020 (Old P/N P 59342-00000)
2HA-2LX PILOTAIR Valve (Detent position 1, 2 & 3 -
 latch positions 1 & 3) Part Number R431005021
 (Old P/N P -059343-00001)

Handle Position	Ports Supplied	
	Out 1	Out 2
1		
2		X
3	X	X

2-HA-2U PILOTAIR Valve (with detents 1, 2 & 3)
 Part No. R431006413 (Old P/N P -064417-00000)

Handle Position	Ports Supplied	
	Out 1	Out 2
1		X
2	X	X
3		

X denotes port supplied in that position.
 Empty block denotes port exhausted in that position.

ORDERING REFERENCE

4-Way Exhaust Center Valves - 3 Position Handle

2-HA-2 PILOTAIR Valve (with detents 1,2 & 3)
 Part Number R431005003 (Old P/N P -059335-00000)
 with chrome plated cover and hub - Part No. R431005005
 (Old P/N P -059335-00003)
 with black coated cover and hub - Part No. R431005004
 (Old P/N P -059335-00002)
 with long handle - Part Number R431005820
 (Old P/N P -061652-00000)

2-HA-2L PILOTAIR Valve (Detents positions 1,2 & 3 - Latch
 positions 1 & 3) Part Number R431005006
 (Old P/N P -059336-00003)
 with black coated cover and hub - Part No. R431005007
 (Old P/N P -059336-00004)

2-HA-2L PILOTAIR Valve (Detents positions 1, 2 & 3)
 Part Number R431006008 (Old P/N P -062082-00000)
 with chrome plated cover and hub - Part No. R431006010
 (Old P/N P -062082-00002)
 with black coated cover and hub - Part No. R431006009
 (Old P/N P -062082-00001)

2-HA-2L PILOTAIR Valve (Detents positions 1,2 & 3 - latch
 position 2 only) Part Number R431005927
 (Old P/N P -061966-00000)

2-HA-2Z PILOTAIR Valve (spring centered)
 Part Number R431005013 (Old P/N P -059339-00000)
 with chrome plated cover and hub - Part No. R431005015
 (Old P/N P -059339-00003)
 with black coated cover and hub - Part No. R431005014
 (Old P/N P -059339-00002)

Handle Position	Ports Supplied	
	Out 1	Out 2
1		X
2		
3	X	

*Maximum inlet pressure 150 psi (10.3 bar)

4-Way Supplied Center Valves - 3 Position Handle

2-HA-2R PILOTAIR Valves (with detents)
 Part Number R431005008 (Old P/N P -059337-00000)
 with chrome plated cover and hub - Part No. R431005009
 (Old P/N P -059337-00002)
 with black coated cover and hub - Part No. R431005010
 (Old P/N P -059337-00003)
 with long handle - Part Number R431005754
 (Old P/N P -061326-00000)

2-HA-2LR PILOTAIR Valves (Detents positions 1,2 & 3 -
 latch
 position 1 & 3) Part Number R431005011
 (Old P/N P -059338-00002)

2-HA-2LR PILOTAIR Valves (Detents and latch in positions
 1, 2 & 3) Part No. R431005012 (Old P/N P -059338-00003)

Handle Position	Ports Supplied	
	Out 1	Out 2
1		X
2	X	X
3	X	

“A” Pilotair® Pneumatic Directional Control Valves
Panel-Mounted Valves, Double Three-Way Valve, Five Position Handle

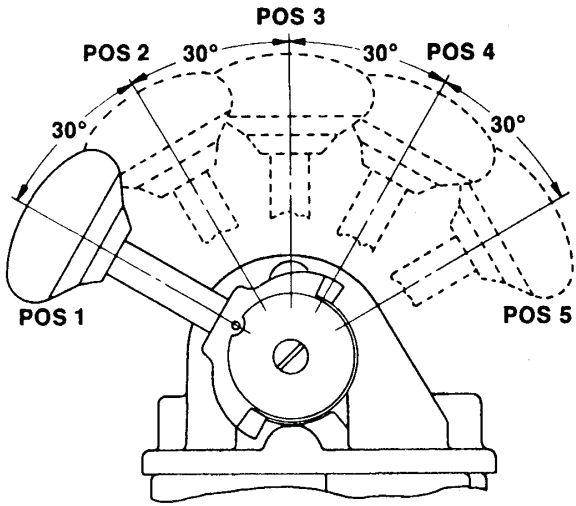

ORDERING REFERENCE

Double 3-Way Valve - 5 Position Handle

2-HA-2F PILOTAIR Valve (with detents)
 Part Number R431003360 (Old P/N P -054427-00001)
 with black coated cover and hub - Part No. P -054427-00003

Handle Position	Ports Supplied	
	Out 1	Out 2
1	X	X
2	X	
3		
4		X
5	X	X

**“A” Pilotair[®] Pneumatic Directional Control Valves
Panel-Mounted Valves**

2-HA-3 and 2-HA-4 Pilotair Valves

The 2-HA-3 and 2-HA-4 models are an extension of the 2-HA-2 models. They were created to furnish a housing that will operate up to four 3-way valves to provide a variety of functions.

The body assembly of the 2-HA-3 and 2-HA-4 models is made up of two 2-HA-2 bodies under a single housing. The supply port of each body requires a separate supply source. The 2-HA-3 model has one cavity plugged to provide a three unit assembly, usually cavity 1L.

These valves were designed primarily for use with multiposition cylinders for Transmission Controls. They also meet the application requirements for

two different supply pressures, selector functions and directional control of up to four different circuits.

It is possible to operate all four valves with a single handle or in any combination from one to three valves with the left hand handle or with the right hand handle.

Double handle assemblies are provided for space conservation and for applications requiring two handles located adjacent to each other. Thus, two different functions can be controlled. As an example, the left handle can control direction (forward or reverse) and the right handle, range (1st, 2nd, 3rd and 4th gear).

MULTI-WAY OPERATION - THREE AND FOUR UNIT VALVES - GATED SINGLE HANDLE

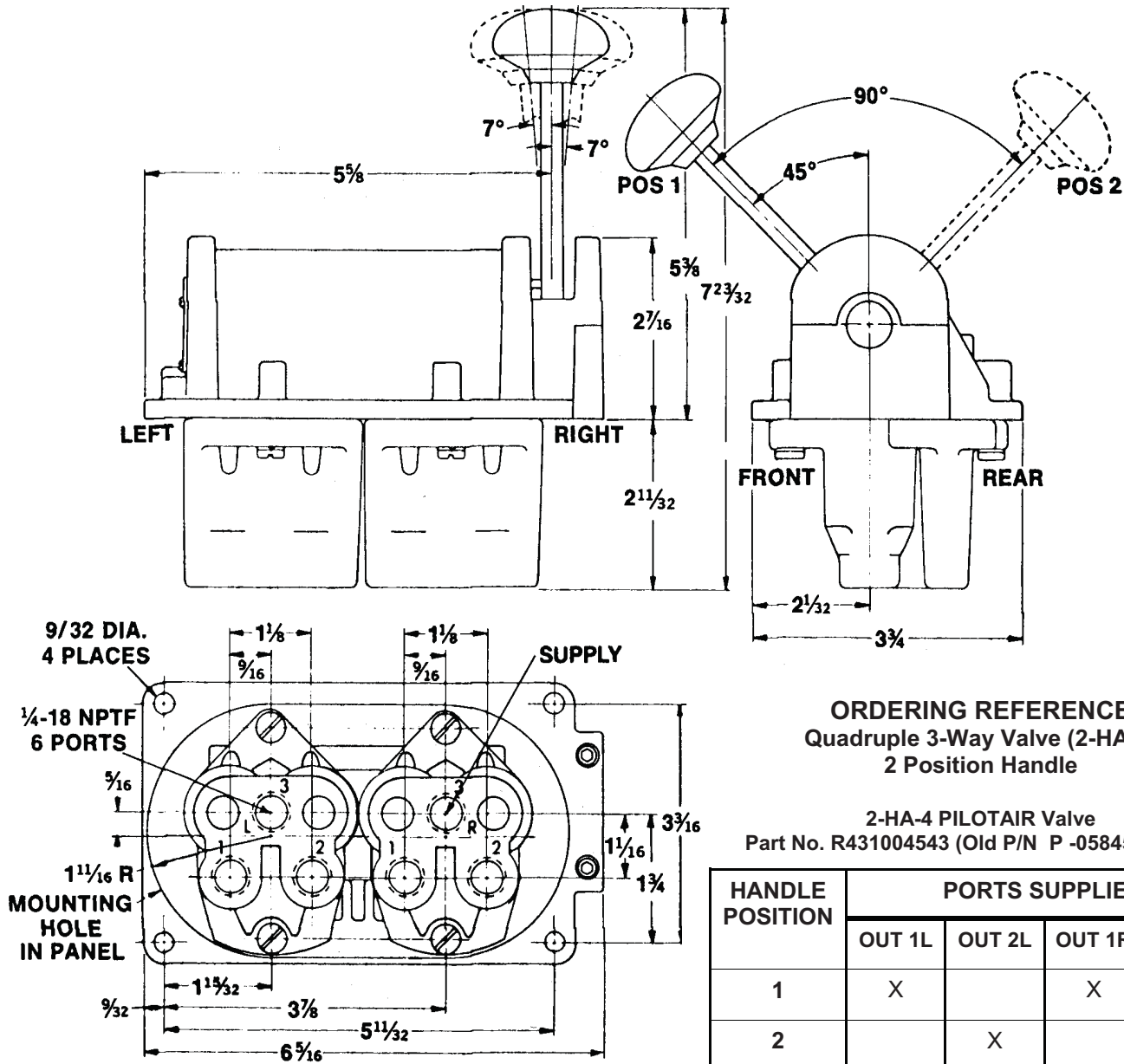

ORDERING REFERENCE
Quadruple 3-Way Valve (2-HA-4)
2 Position Handle

2-HA-4 PILOTAIR Valve
 Part No. R431004543 (Old P/N P-058457-00001)

HANDLE POSITION	PORTS SUPPLIED			
	OUT 1L	OUT 2L	OUT 1R	OUT 2R
1	X		X	
2		X		X

“A” Pilotair® Pneumatic Directional Control Valves
Panel Mounted Valves, Multi-Function Operation

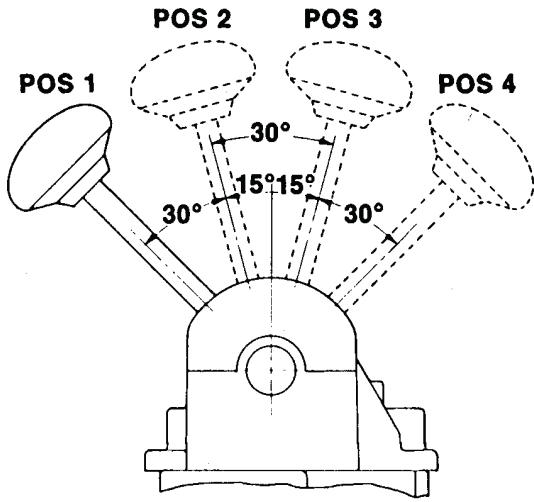

2-HA-3 PILOTAIR Valve
 Part No. R431004511 (Old P/N P -058378-00002)

HANDLE POSITION	PORTS SUPPLIED			
	OUT 1L	OUT 2L	OUT 1R	OUT 2R
1	PLUGGED	X		
2				X
3				
*4			X	

**spring-returned to position 3*

ORDERING REFERENCE

Triple (2-HA-3) and Quadruple (2-HA-4) 3-Way Valves,
 4 Position Gated Single Handle

2-H-3 PILOTAIR Valve
 Part No. R431004510 (Old P/N P -058374-00001)

HANDLE POSITION	PORTS SUPPLIED			
	OUT 1L	OUT 2L	OUT 1R	OUT 2R
1	PLUGGED		X	
2			X	X
3		X		X
4		X		

2-HA-4 PILOTAIR Valve
 Part No. R431005485 (Old P/N P -060324-00000)

HANDLE POSITION	PORTS SUPPLIED			
	OUT 1L	OUT 2L	OUT 1R	OUT 2R
1		X		
2				X
3	X			
4			X	

ORDERING REFERENCE

Triple (2-HA-3) and Quadruple (2-HA-4) 3-Way Valves

5 POSITION GATED SINGLE HANDLE

2-HA-3 PILOTAIR Valve - Part Number R431004512
 (Old P/N P -058379-00001)

2-HA-3 PILOTAIR Valve (Spring return to positions 3 & 4 -
 Replaces B-3 Pilotair Valve) - Part Number R431006034
 (Old P/N P -062269-00000)

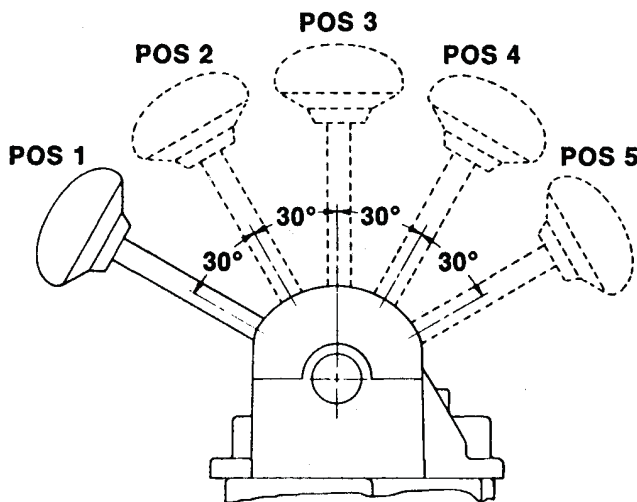

HANDLE POSITION	PORTS SUPPLIED			
	OUT 1L	OUT 2L	OUT 1R	OUT 2R
1	PLUGGED			X
2				
3			X	
4				
5		X		

“A” Pilotair[®] Pneumatic Directional Control Valves
Panel-Mounted Valves Ordering Reference
Triple (2-HA-3) and Quadruple (2-HA-4) 3-Way Valves - 5 Position Gated Single Handle

2-HA-3 PILOTAIR Valve
 Part No. R431009019 (Old P/N P -060877-00000)

HANDLE POSITION	PORTS SUPPLIED			
	OUT 1L	OUT 2L	OUT 1R	OUT 2R
1	PLUGGED		X	
2				
3		X		
4				
5				

2-HA-4 PILOTAIR Valve (For 5-pos. trans. cylinder)
 Part No. R431004541 (Old P/N P -058455-00002)

HANDLE POSITION	PORTS SUPPLIED			
	OUT 1L	OUT 2L	OUT 1R	OUT 2R
R		X		
N		X		X
F ₁			X	X
F ₂	X		X	
F ₃			X	

2-HA-4 PILOTAIR Valve
 Part No. R431005386 (Old P/N P -060056-00000)

HANDLE POSITION	PORTS SUPPLIED			
	OUT 1L	OUT 2L	OUT 1R	OUT 2R
1	X	X		
2	X			
3				
4			X	
5			X	X

2-HA-4 PILOTAIR Valve
 Part No. R431005740 (Old P/N P -061274-00000)

HANDLE POSITION	PORTS SUPPLIED			
	OUT 1L	OUT 2L	OUT 1R	OUT 2R
1	X		X	
2	X		X	X
3	X			X
4	X	X		X
5		X		X

2-HA-4 PILOTAIR Valve
 Part No. R431009113 (Old P/N P -058381-00001)

HANDLE POSITION	PORTS SUPPLIED			
	OUT 1L	OUT 2L	OUT 1R	OUT 2R
1		X		X
2				X
3	X			X
4	X		X	X
5	X		X	

2-HA-4 PILOTAIR Valve
 Part No. R431004542 (Old P/N P -058456-00001)

HANDLE POSITION	PORTS SUPPLIED			
	OUT 1L	OUT 2L	OUT 1R	OUT 2R
1		X	X	
2		X		X
3				
4	X		X	
5	X			X

2-HA-4 PILOTAIR Valve (For 5-pos. “E” cylinder)
 Part No. R431004801 (Old P/N P -058892-00001)

HANDLE POSITION	PORTS SUPPLIED			
	OUT 1L	OUT 2L	OUT 1R	OUT 2R
1				X
2	X			X
3	X	X		X
4	X	X	X	
5		X	X	

2-HA-4 PILOTAIR Valve
 Part No. R4310055403 (Old P/N P -060153-00000)

HANDLE POSITION	PORTS SUPPLIED			
	OUT 1L	OUT 2L	OUT 1R	OUT 2R
1				
2	X			
3		X		
4			X	
5				X

2-HA-4 PILOTAIR Valve
 Part No. R431005803 (Old P/N P -061619-00000)

HANDLE POSITION	PORTS SUPPLIED			
	OUT 1L	OUT 2L	OUT 1R	OUT 2R
1	X	X	X	X
2	X	X		X
3	X	X	X	
4	X		X	X
5		X	X	X

“A” Pilotair® Pneumatic Directional Control Valves
Panel Mounted Valves, Quadruple Three-Way Valves (2-HA-4)

QUADRUPLE THREE-WAY VALVES (2-HA-4)
4 and 5 POSITION GATED SINGLE HANDLE
 (see page 20 for handle position diagrams)

2-HA-4 PILOTAIR Valve
 Part No. R431004540 (Old P/N P -058454-00001)

Handle Position	Ports To Which Pressure Is Supplied			
	Single Right Handle			
	Out 1L	Out 2L	Out 1R	Out 2R
1		X		X
2		X		
3			X	
4	X			

2-HA-4 PILOTAIR Valve
 Part No. R431006038 (Old P/N P -062275-00000)

Handle Position	Ports To Which Pressure Is Supplied			
	Single Right Handle			
	Out 1L	Out 2L	Out 1R	Out 2R
1	X			
2		X		
3				
4			X	
5				X

2-HA-4 PILOTAIR Valve
 Part No. R431006000 (Old P/N P -062068-00000)

Handle Position	Ports To Which Pressure Is Supplied			
	Single Right Handle			
	Out 1L	Out 2L	Out 1R	Out 2R
1	X			
2	X	X		
3		X	X	
4			X	X

X denotes port supplied in that position.
 Empty block denotes port exhausted in that position.

Consult Factory for outline drawings and other details on the above models.

These Diagrams illustrate the versatility of the 2-HA-2, 2-HA-3 and 2-HA-4 “A” Pilotair Valves. Many other porting and handle configurations are possible within the following general guidelines.

- 2, 3, 4, 5 Handle Positions
- Detented or Gated Handle Arrangements
- 2, 3 and 4 Three-Way Valve Combinations

Consult Factory For Special Porting Operations Not Listed.

“A” Pilotair[®] Pneumatic Directional Control Valves
Panel Mounted Valves
2-HA-3 and 2-HA-4 Multi-Way Operation - Three and Four Unit Valves
Detented Single Handle

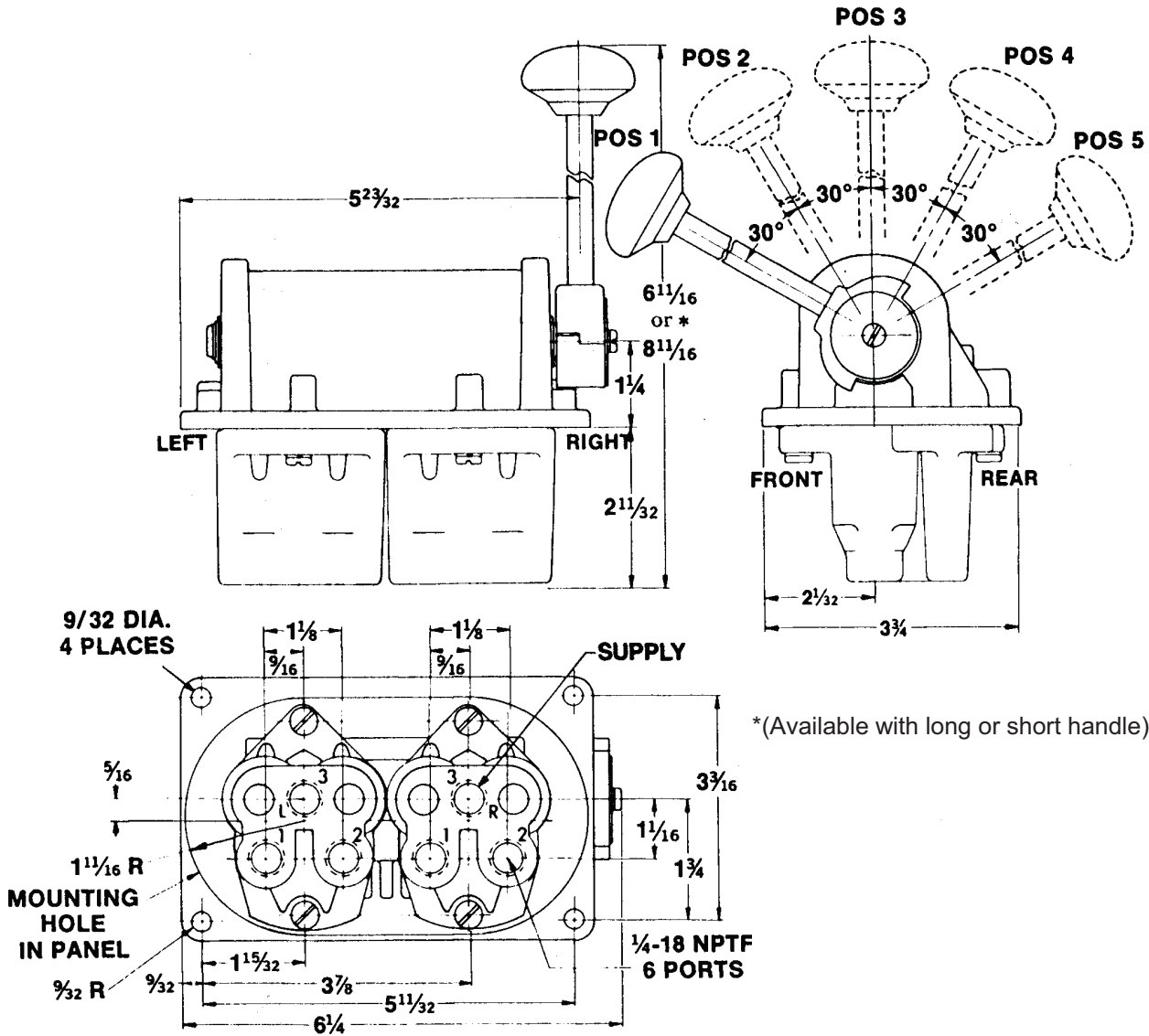

*(Available with long or short handle)

ORDERING REFERENCE

Quadruple (2-HA-4) 3-Way Valve, Five Position Handle

2-HA-4 PILOTAIR Valve (short handle)

Part Number R431005632 (Old P/N P -060957-00000)

additional models on following page

Handle Position	Ports Supplied			
	Single Right Handle			
	Out 1L	Out 2L	Out 1R	Out 2R
1		X	X	
2		X		X
3				
4	X		X	
5	X			X

“A” Pilotair® Pneumatic Directional Control Valves
Panel Mounted Valves, Triple 3-Way Valve 2-HA-3 Models

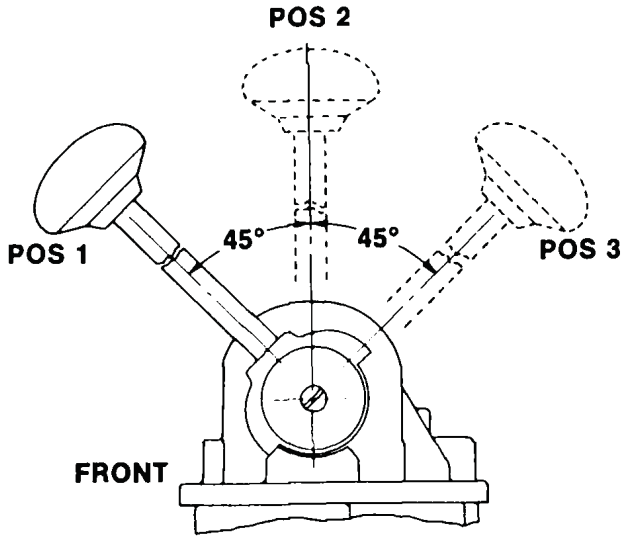

ORDERING REFERENCE

Triple (2-HA-3) 3-Way Valve

3 Position Handle, Detented

2-HA-3 PILOTAIR Valve (long handle)
Part No. R431005733 (Old P/N P -061266-00001)

HANDLE POSITION	PORTS SUPPLIED			
	OUT 1L	OUT 2L	OUT 1R	OUT 2R
1	PLUGGED		X	
2		X		
3				X

2-HA-3 PILOTAIR Valve
Part No. R431005734 (Old P/N P -061266-00002)

HANDLE POSITION	PORTS SUPPLIED			
	OUT 1L	OUT 2L	OUT 1R	OUT 2R
1	PLUGGED	X	X	
2				X
3			X	

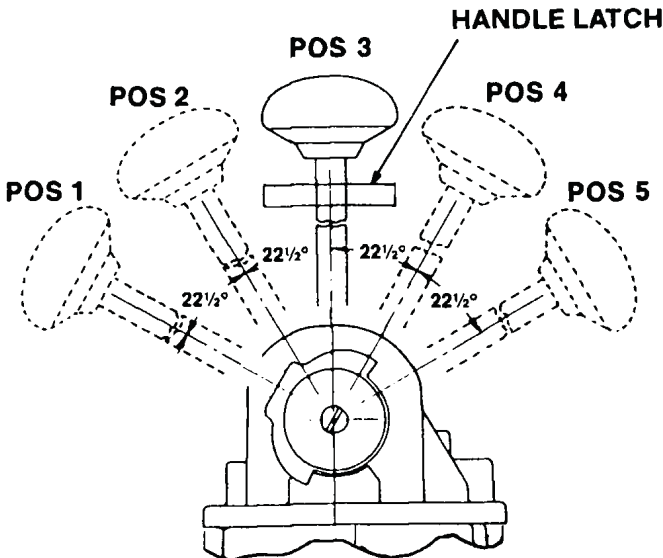

Triple (2-HA-3) 3-Way Valve

5 Position Handle, Spring Centered

2-HA-3L PILOTAIR Valve
Part No. R431007396 (Old P/N P -069079-00000)

Handle Position	Ports To Which Pressure Is Supplied			
	Spring Return To Position 3 Special Handle Latch at Position 3 22½° Handle Travel Between Positions			
	Out 1L	Out 2L	Out 1R	Out 2R
1	Plugged	X	X	
2	Plugged	X		
3	Plugged			
4	Plugged	X		
5	Plugged	X		X

“A” Pilotair[®] Pneumatic Directional Control Valves
Panel Mounted Valves, Multi-Way Operation—Three and Four Unit Valves

2-HA-3 and 2-HA-4
Multi-Way Operation—Three and Four Unit Valves
Gated Double Handle*

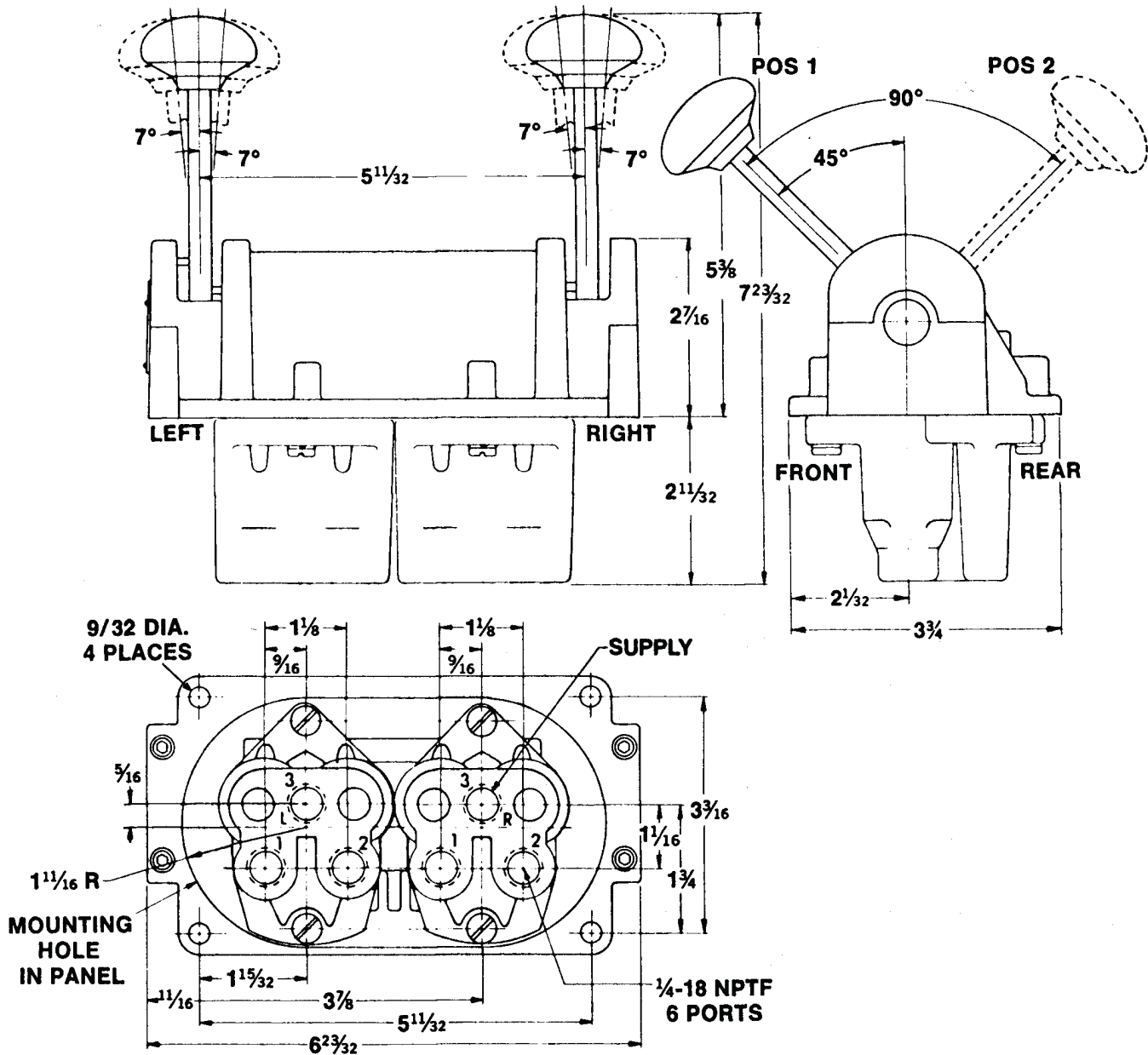

*Position 1 is always to the front of the valve regardless of left or right handle.

“A” Pilotair® Pneumatic Directional Control Valves
Panel Mounted Valves, Triple and Quadruple 3-Way Valves, Double Handle Operation

ORDERING REFERENCE

TRIPLE (2-HA-3) and QUADRUPLE (2-HA-4) 3-WAY VALVES - DOUBLE HANDLE OPERATION

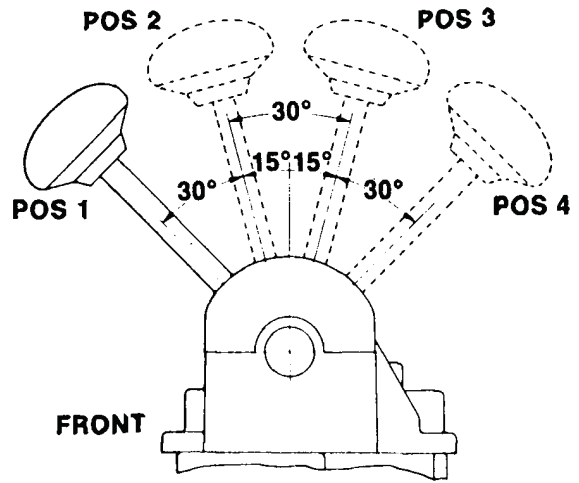
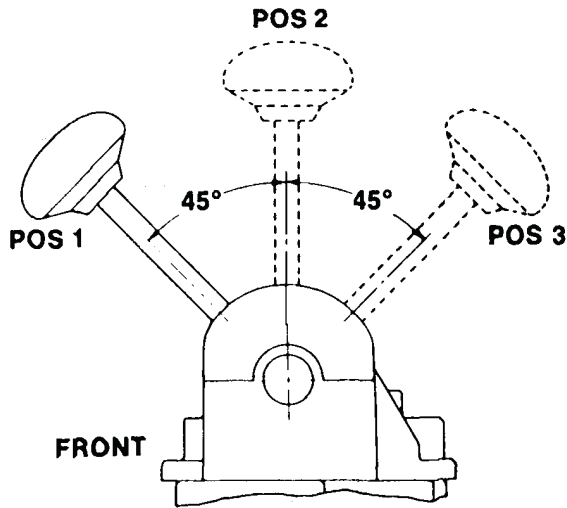

2-HA-3 PILOTAIR Valve
 (2 positions right handle, 3 positions left handle)
 Part No. R431004513 (Old P/N P -058380-00001)

HANDLE POSITION	PORTS SUPPLIED			
	LEFT HANDLE		RIGHT HANDLE	
	OUT 1L	OUT 2L	OUT 1R	OUT 2R
1		X	PLUGGED	X
2	X	X		
3	X			

2-HA-4 PILOTAIR Valve
 (3 positions both handles)
 Part No. R431004537 (Old P/N P -058451-00001)

HANDLE POSITION	PORTS SUPPLIED			
	LEFT HANDLE		RIGHT HANDLE	
	OUT 1L	OUT 2L	OUT 1R	OUT 2R
1		X		X
2			X	X
3	X		X	

2-HA-4 PILOTAIR Valve
 (3 positions both handles)
 Part No. R431004541 (Old P/N P -058458-00001)

HANDLE POSITION	PORTS SUPPLIED			
	LEFT HANDLE		RIGHT HANDLE	
	OUT 1L	OUT 2L	OUT 1R	OUT 2R
1		X		X
2				
3	X		X	

**“A” Pilotair[®] Pneumatic Directional Control Valves
Panel Mounted Valves, Quadruple Three-Way Valves (2-HA-4)
Gated Double Handle**

GATED DOUBLE HANDLE

2-HA-4 PILOTAIR Valve
Part Number P -058377-00001

Handle Position	Ports To Which Pressure Is Supplied			
	Left Handle		Right Handle	
	Out 1L	Out 2L	Out 1R	Out 2R
1		X		X
2	X		X	X
3			X	

2-HA-4 PILOTAIR Valve
Part Number P -059069-00001

Handle Position	Ports To Which Pressure Is Supplied			
	Left Handle		Right Handle	
	Out 1L	Out 2L	Out 1R	Out 2R
1		X		X
2			X	
3	X			

X denotes port supplied in that position.
Empty block denotes port exhausted in that position.

**“A” Pilotair® Pneumatic Directional Control Valves
Three Way-Normally Closed Cartridge Valves**

Technical Data:

Materials	Plastic and Stainless Steel
Operating Pressure (max)	250 psi (17.2 bar)
Ambient Temperature	-40 to 160°F (-40 to 71°C)
Operating Medium	Air
Weight	1.2 oz. (34 g)

OPERATION

The “A” PILOTAIR® cartridge valve is a mechanically operated (straight push) 3-way directional control valve. It can be easily used in manifolds or in custom installations. This cartridge valve can also be used to graduate pressure (consult factory for additional information).

In release position, as shown, the valve disc seals on the inlet valve seat and closes the passage from the inlet to the outlet. The outlet is vented to atmosphere through the center of the plunger. As the plunger is forced downward by an external force, it seats on the valve disc. This seals the passage between the outlet and exhaust.

Further downward travel of the plunger unseats the valve disc from the inlet valve seat and allows inlet air pressure to flow to the outlet.

Release of the external force, allows the plunger and valve to spring return to the original position.

Install the valve to ensure operation within the travel limits shown on the outline drawings. Travel beyond these limits can cause damage to the valve.

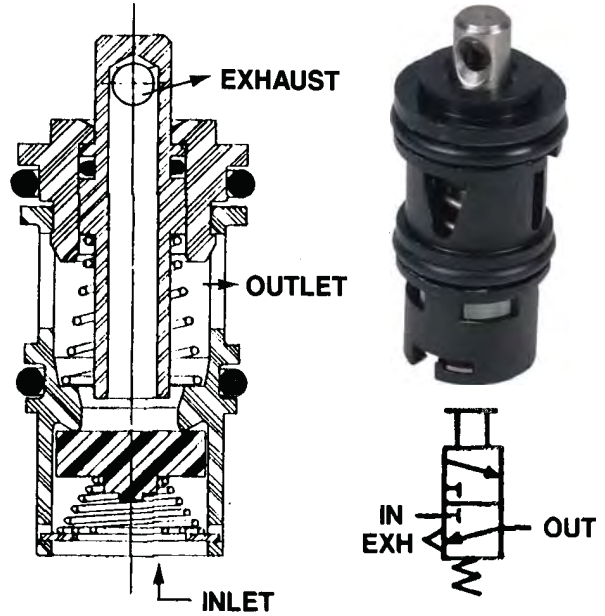

Description	Part Number	Old P/N
Cartridge Alone	R431003743	P -055474-K0002
Cartridge with Retaining Flange & Screws	R431003742	P -055474-00004

TOLERANCES - Unless specified otherwise	
TYPE	FINISHED
DEC .00	± .015
DEC .000	± .005
ANGLES	± 1/2°

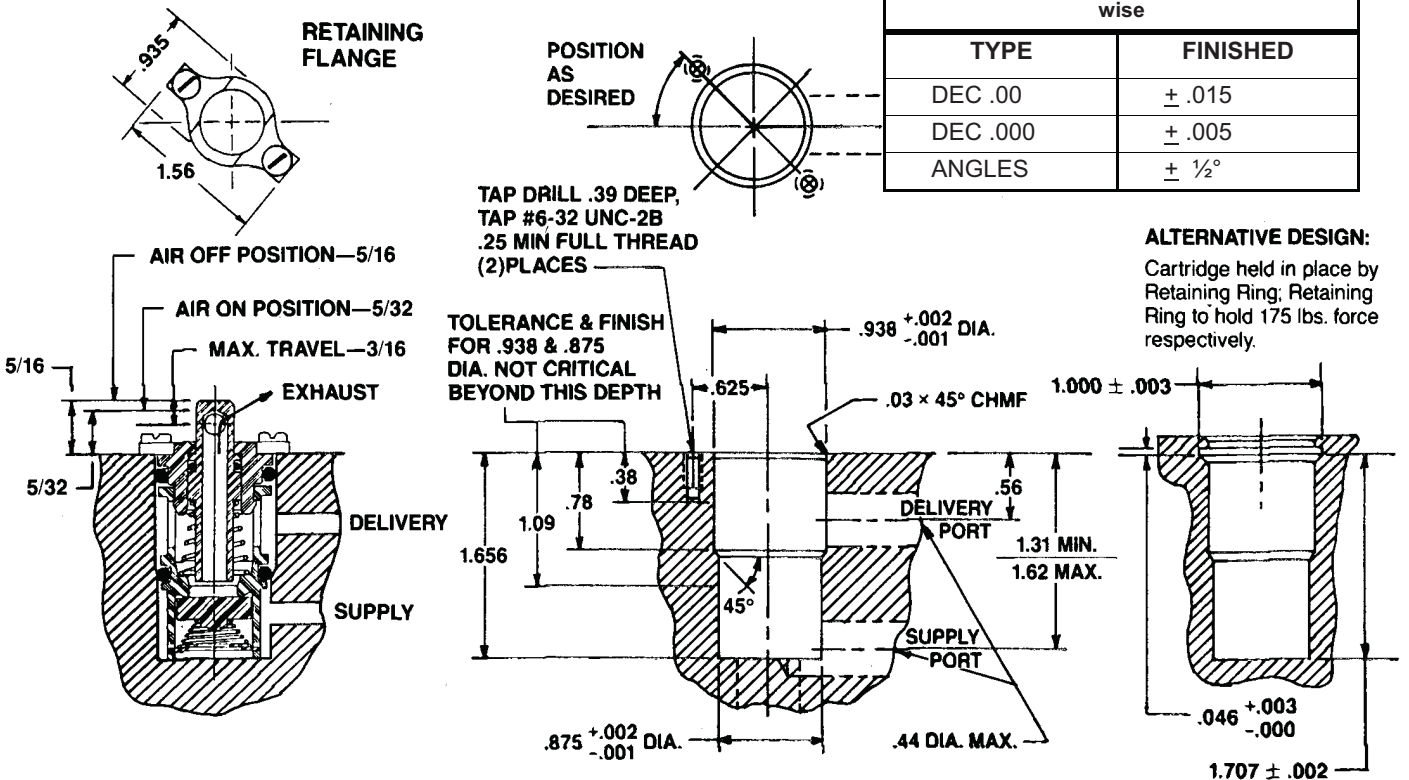

ALTERNATIVE DESIGN:
Cartridge held in place by Retaining Ring. Retaining Ring to hold 175 lbs. force respectively.

“A” Pilotair[®] Cartridge-Repair Kits**“A” PILOTAIR[®] CARTRIDGE**

CARTRIDGE REPAIR KIT
 Part Number R431003743
 (Old P/N P -055474-K0002)

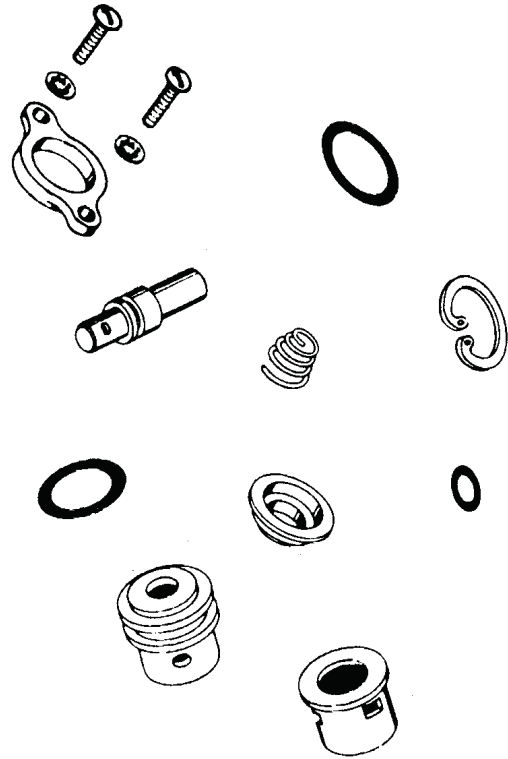

**OLD MAJOR
 REPAIR KIT**

- Simplified Repair
- Factory Tested
- Fits Most Previous Design “A” Pilotair Valves
- Corrosion Resistant

The one piece valve cartridge replaces the individual valve parts assembly for the following devices:

“A” PILOTAIR Valves
 “H” CONTROLAIR Valves
 FLEXAIR Valves - Side Valve Cavity

See next page for Part Number List

Quick, positive repair and conversion can be accomplished by directly replacing the old individual parts with the current factory pressure tested cartridge. The cartridge valve simplifies repair and eliminates possible problems due to improper parts assembly. The modern engineered plastic and stainless steel construction provide superior corrosion resistance and sealing characteristics.

NOTE:

With the above kits, the elastomer seals and some common wear parts in the valve portions of the assemblies can be repaired. On severely worn or damaged valves, additional parts may be required.

The above kits do not contain any parts for the mechanical operating portions of the valves. The mechanical operating portions of the valve should be repaired when necessary, with individually selected parts, and tested before being put in service.

Refer to Service Bulletin SM-700.7400 for additional parts information and service instructions on the type “A” PILOTAIR pneumatic directional valves.

“A” Pilotair[®] Cartridge—Repair Kits

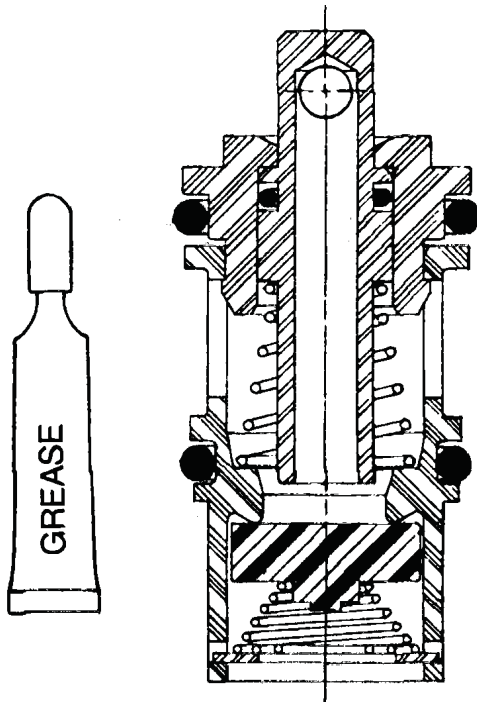

CARTRIDGE REPAIR KIT
R431003743 (Old P/N P -055474-K0002)
“A” PILOTAIR VALVES
CONTROLAIR VALVES
FLEXAIR VALVES, On-Off #3 Valve

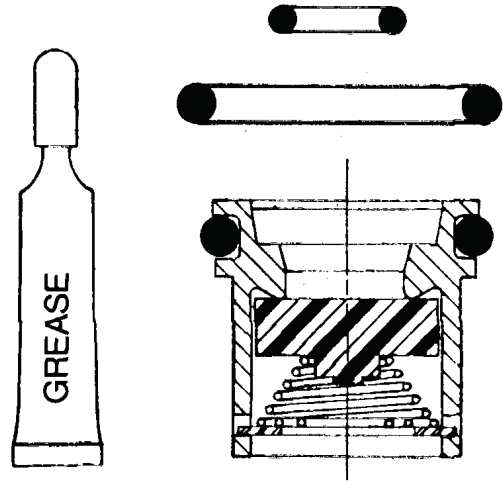

CARTRIDGE REPAIR KIT
R431003229 (Old P/N P -053460-K0006)
FLEXAIR VALVES
Graduated Pressure #3 Valve Only

Valve Description	Mfg Date	Discontinued Repair Kits		Cartridge Repair Kit♦
		Major Kit	Minor Kit	
Block-type “A” PILOTAIR Valves: 2-CA, 2-LA, 2-MA, & 2-PA	After 1968	P -055474-00000	P -055474-00001●	R431003743 (Old P/N P -055474-K0002)
Panel-type “A” PILOTAIR Valves: 2-BA, 2-HA	1969-3/71	P -055474-00000	P -055474-00001●	R431003742 (Old P/N P -055474-00004▲) R431003743 (Old P/N P -055474-K0002)
	After 3/71	P -055474-00000	P -055474-00001●	
FLEXAIR Valves On-Off #3 Valve Graduating #3 Valve			P -053460-00004 P -053460-00004	R431003743 (Old P/N P -055474-K0002) R431003229 P -053460-00006●

NOTES:

- ♦ 1. To maintain valve performance, the complete cartridge should be replaced on all repairs.
- 2. Kits repair only one valve cavity. Complete valves with two or more cavities (such as 2-HA-2, 2-HA-3 and 2-HA-4) will require multiple kits.
- ▲ 3. Panel mounted 2-BA and 2-HA valves manufactured between 1969 and 1971 used die cast flange retainer to hold the valve parts in the body cavity Kit R431003742 (Old P/N P -055474-00004) includes a new flange and screws to service these valves.
- 4. Kit R431003229 (Old P/N P -053460-K0006) can be used as a minor repair kit for valves that do not have the new cartridge installed.

**“D” Pilotair[®] Valves
Index and Descriptions**

INDEX AND DESCRIPTIONS

The Type “D” PILOTAIR Valve line includes the following basic valves:

Two-way.....	Page 37
Three-way, open Exhaust	Page 38
Three-way Valve, Tapped Exhaust, Closed Center	Page 39
Four-way Valve, Open Exhaust, Closed Center	Page 40
Four-way Valve, Tapped Exhaust, Closed Center	Page 41
Four-way Valve, Open Exhaust, Exhaust Center	Page 42
Four-way Valve, Tapped Exhaust, Exhaust Center	Page 43
Four-way Valve, Tapped Exhaust, Open Center	Page 43

The above valves can be operated by any of the following operators, all which have several variations of spring return and holding functions.

Lever	Solenoid*
Button	Pedal
Button, Panel Mounting	Treadle
Cam	Low Pressure
Air Pilot Cylinder	Pilot Cylinder

Select the type of valve operation required and then determine the type or types of operators to be used. Tabulations on pages 35 thru 41 list the part numbers to be used for ordering the most commonly used combinations. Also include the complete description of the valve to eliminate the possibility of error.

Example: Part Number PD4-31-1007, ½” Three-way Valve, Open Exhaust, Pilot Cylinder Operator “A” End, Cam Operator “B” End, No Return Springs (page 36).

See page 44 for ordering combination not listed in these tabulations.

OPERATORS

Passages through the Type “D” PILOTAIR Valve are opened and closed by an operator or operators moving a spool to a fixed position at either end of its travel. Some valves have a third or center position midway between these two fixed positions. Any of the available operators may be used on either two or three-position valves. The spring return functions, however, will vary according to the number of positions. Operators can be furnished with No Spring Return, Full Return Springs or Centering Springs.

NO SPRING RETURN -Used on either two-or three-position valves. Operators with no spring return remain in position when the operating force is removed. Note - return springs must be used with any remote or mechanically operated valve. Manual operators may be used with or without return springs. When two operators are used on one valve, the spool is returned by the opposite operator. Lever or Button Operators without spring return may also be used with a detent kit on the opposite end.

FULL RETURN SPRING - Used on two-position valves. When the operating force is removed, the spool is return to its normal extreme position. The spring may be a part of the operator or assembled on the opposite end of the valve, depending on whether the valve is normally-open or normally-closed.

CENTER SPRINGS - Used on three-position valves. Centering spring hold the spool in its center position. This return function can be used on either single-operator or double-operator valves.

**Piped Solenoid Operators also available. See page 42.*

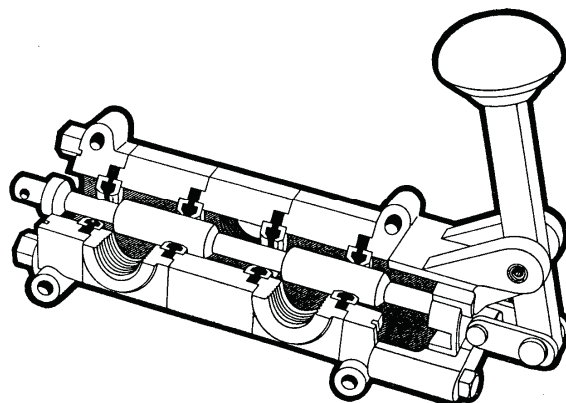

“D” Pilotair[®] Valves

Features and specifications

POSTIVE SEALING - A unique seal design made from an oil-resistant material developed in the AVENTICS laboratories gives the Type “D” PILOTAIR Valve long service life with minimum maintenance at high operating pressures. In the presence of lubrication oil, this material swells minutely to compensate for seal wear.

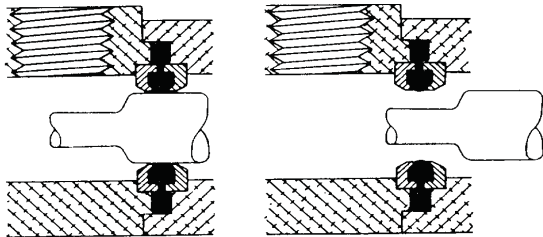

Triple support construction gives an interference fit between the spool and seal to provide sealing effectiveness beyond that of conventional O-ring sealed valves. This same construction ensures that the seals remain in position and are protected from damage by the moving spool. Valves are factory tested for bubble-tight sealing.

VERSATILE - There is no standard assembly of the Type “D” PILOTAIR Valve. The directional valve you need is easily tailed to your installation - at standard model prices. Any of nine basic valves may be operated by one or two of eight basic operators. The Type “D” PILOTAIR Valve may have an operator on either or both ends. Various operator spring return and holding functions are available. The valve operators, mounting bracket or any of the port segments may be rotated in 90 degree increments to fit most any installation problem.

Most valves are made from common parts to simplify repair and stocking. No special tools are required to service or modify Type “D” PILOTAIR Valves.

The type “D” PILOTAIR Valve can be used for functions other than directional control (see “Pilot Cylinder Operator” and “Low Pressure Pilot Cylinder” on pages 35 and 36).

DEPENDABLE - Dependability is always a AVENTICS feature. Design simplicity provides long service life with a minimum of maintenance. Uncomplicated parts simplify service problems. The Type “D” PILOTAIR Valve has been proven in millions of cycles in many types of applications.

The Type “D” PILOTAIR Valve operates in any position. Maximum operating pressure of the valve is 250 psi (17.2 bar) (solenoid pilot operator 150 psi (10.3 bar)). Standard operating temperature range is -20°F to + 160° F (-29° to +71°C). Special seals are available for -65°F to +300°F operation.

DURABLE - The Type “D” PILOTAIR Valve is constructed of corrosion-resistant materials. All valve bodies and operator housings are anodized aluminum. The spool is stainless steel. Most other internal parts are nickel-zinc plated.

CAPACITY - As shown by the charts, the Type “D” PILOTAIR Valve is designed to provide maximum capacity flow to speed operations and to provide full power.

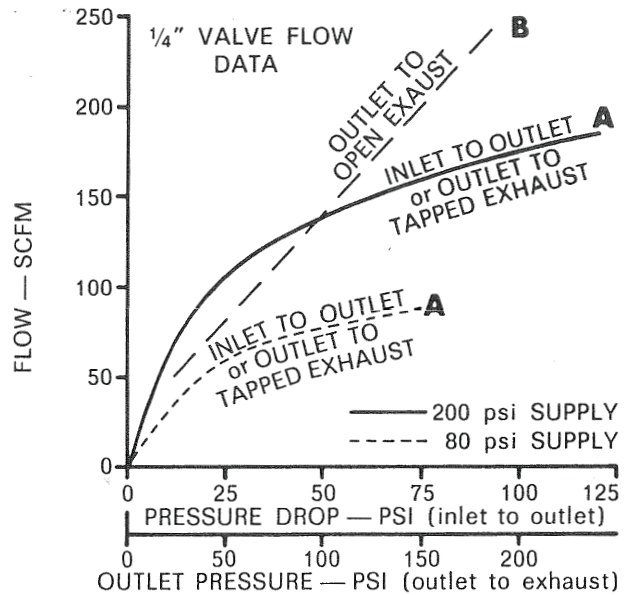

“A” FLOW FACTOR = .83 $C_v = 1.47$
 “B” FLOW FACTOR = 1.2 $C_v = 2.12$

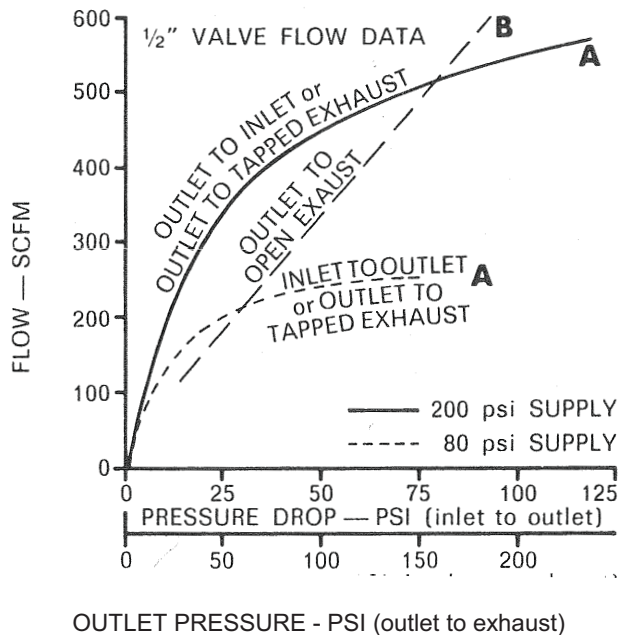

To determine flow from inlet to outlet for any pressure drop (permissible difference between inlet and outlet pressure), project up from the Pressure Drop scale to the dotted curve for 80 psi (5.5 bar) supply and to the solid curve for 200 psi (13.8 bar). At this intersection, project to the left for the resulting flow on the vertical scale. To determine flow from outlet to exhaust, project up from the Outlet Pressure scale to the dash-line curve and then to the left for the resulting flow.

“D” Pilotair[®] Valves
Basic Valve Portions Dimensions

BASIC VALVE
(two-way and three-way open exhaust)

A	B	C	D	E	F	G	H	J
1/4"	5 11/16	5 3/8	3/16	13/16	1	7/8	1	1 11/16
1/2"	6 11/16	6 9/16	1/4	1 1/16	1 7/16	1 3/16	1 5/16	1 11/16

K	L	M	N	P	Q	R	S
1/8	1 7/8	15/16	1 5/8	1 5/8	13/16	2	7/32
3/16	2 1/8	1 1/16	1 7/8	1 15/16	31/32	2 7/16	9/32

Net Weight 1/4" -- 15 oz (0.43 Kg);
1/2" -- 1 lb. 13

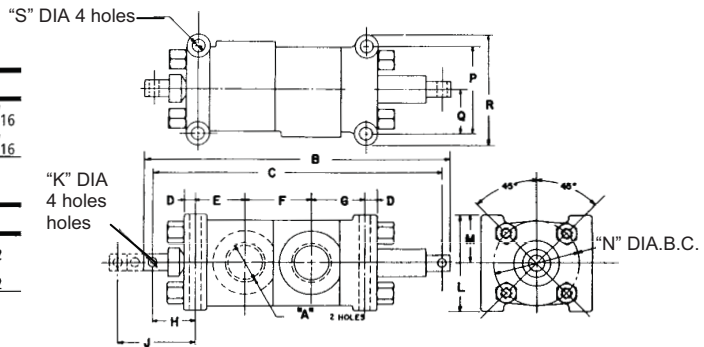

BASIC VALVE
(three-way, tapped exhaust and four-way, open exhaust)

A	B	C	D	E	F	G	H	J
1/4"	6 11/16	6 3/8	3/16	13/16	1	7/8	1	1 11/16
1/2"	8 1/8	7 3/4	1/4	1 1/16	1 7/16	1 3/16	1 5/16	1 11/16

K	L	M	N	P	Q	R	S
1/8	1 7/8	15/16	1 5/8	1 5/8	13/16	2	7/32
3/16	2 1/8	1 1/16	1 7/8	1 15/16	31/32	2 7/16	9/32

Net Weight: 1/4" -- 1 lb. 3 oz. (0.54 Kg);
1/2" -- 2 lb. 5 oz. (1.05 Kg)

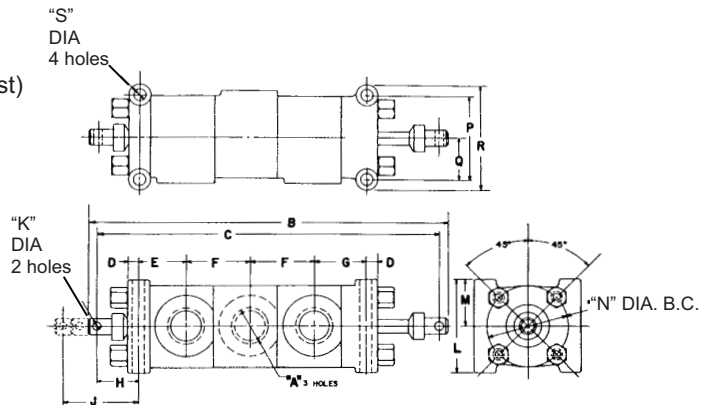

BASIC VALVE
(four-way, tapped exhaust)

A	B	C	D	E	F	G	H	J
1/4"	8 11/16	8 3/8	3/16	13/16	1	7/8	1	1 11/16
1/2"	10 31/32	10 19/32	1/4	1 1/16	1 7/16	1 3/16	1 5/16	1 11/16

K	L	M	N	P	Q	R	S
1/8	1 7/8	15/16	1 5/8	1 5/8	13/16	2	7/32
3/16	2 1/8	1 1/16	1 7/8	1 15/16	31/32	2 7/16	9/32

Net Weight: 1/4" -- 1 lb. 11 oz. (0.77 Kg);
1/2" -- 3 lb. 1 oz. (1.39 Kg)

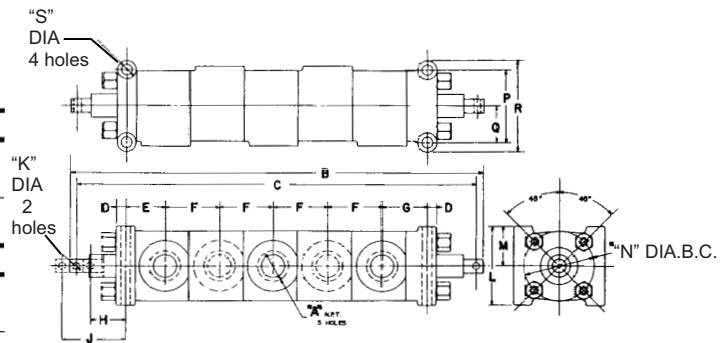

NOTE A -- The attachment holes in each end of the spool may not be in line as shown.

“D” Pilotair® Valves

Valve Operator Selections (Operator code numbers shown on page 46)
Dimensions

LEVER OPERATOR

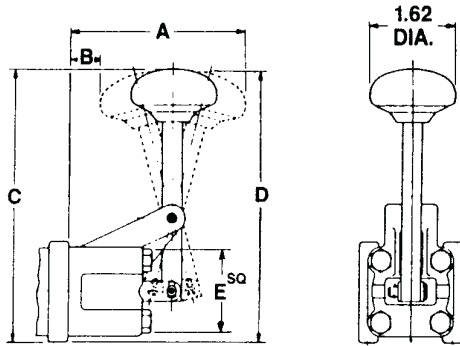

Size	A	B	C	D	E
¼"	3.38	.56	5.12	5.06	1.65

For manual operation. May be for push or pull operation on two- or three-position valves. May also be used with detent kit. Net Weight: ¼" - 9 oz. (0.26 Kg.); ½" - 14 oz. (0.40 Kg.)

BUTTON OPERATORS WITH FLANGE MOUNTING

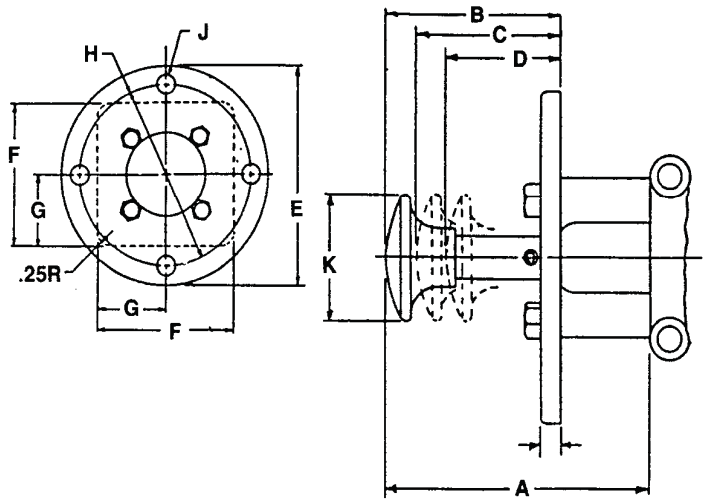

Size	A	B	C	D	E	F	G	H	J	K
¼"	3.62	2.47	2.12	1.78	3.38	2.19	1.09	2.75	.28	1.50
½"	3.56	2.50	2.12	1.75	3.94	2.56	1.28	3.25	.34	1.50

Same as button operator except it contains a mounting flange for panel installation. Net Weight: ¼" - 7 oz. (0.20 Kg.); ½" - 9 oz. (0.26 Kg.)

BUTTON OPERATOR

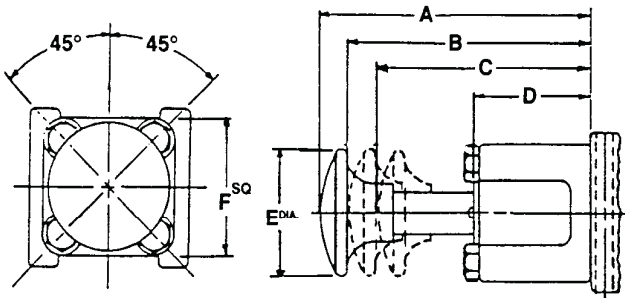

Size	A	B	C	D	E	F
¼"	3.62	3.28	2.94	1.47	1.50	1.65
½"	3.56	3.19	2.81	1.41	1.50	1.95

Finger operation. Generally used on two-position valves with full return spring. May also be used on three-position valves with or without return springs for push or pull operation. May also be used with detent kit. Net Weight: ¼" - 5 oz. (0.14 Kg.); ½" - 7 oz. (0.20 Kg.)

NOSE MOUNT OPERATOR

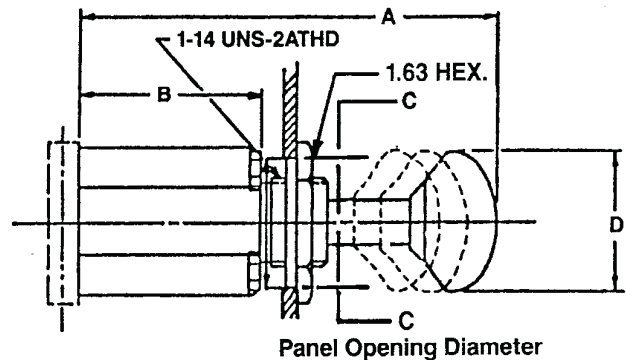

Mounts in control panel hole (1½" DIA). Two and three position integral detents, no additional detent kits required. ¼" valve size only. ¼" - 10 oz. (0.28 Kg.)

“D” Pilotair[®] Valves

Valve Operator Selections (Operator code numbers shown on page 46)
Dimensions

FOOT PEDAL OPERATOR

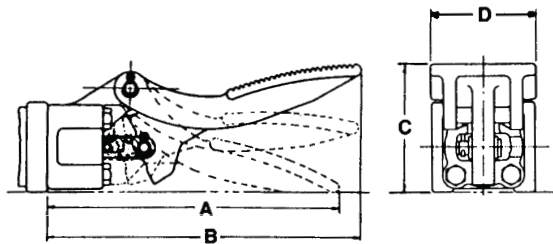

Size	A	B	C	D
1/4"	7.00	7.47	2.81	2.50
1/2"	7.00	7.47	3.06	2.50

Toe-operated. Must have return spring when used as only operator. When used with another operator it should have no return spring. Net Weight: 1/4" - 1 lb. 2 oz. (0.51 Kg.); 1/2" - 1 lb. 4 oz. (0.57 Kg.)

CAM OPERATOR

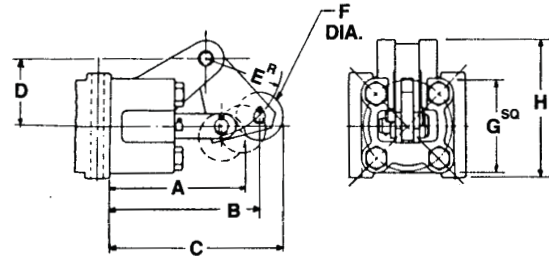

Size	A	B	C	D	E	F	G	H
1/4"	2.69	3.12	3.38	1.38	1.63	.50	1.65	2.56
1/2"	2.81	3.22	3.56	1.38	1.69	1.00	1.95	2.81

Mechanically-operated. Must be used with full return spring or operator on opposite end to return spool. Net Weight: 1/4" - 6 oz. (0.17 Kg.); 1/2" - 8 oz. (0.23 Kg.)

FOOT TREADLE OPERATOR

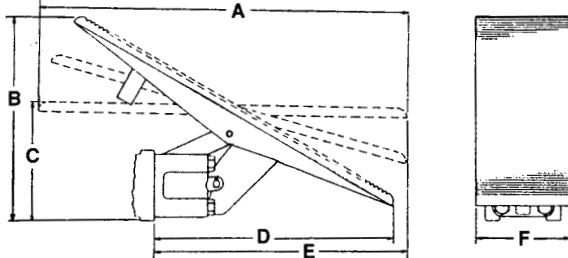

Size	A	B	C	D	E	F
1/4"	9.75	5.47	3.19	6.25	6.69	2.50
1/2"	9.75	5.75	3.44	6.25	6.69	2.50

Foot-operated. May be used with no return spring or with centering springs. Ordinarily would not be used with another operator. Net Weight: 1/4" - 1 lb. 4 oz. (0.57 Kg.); 1/2" - 1 lb. 11 oz. (0.77 Kg.)

PILOT CYLINDER OPERATOR

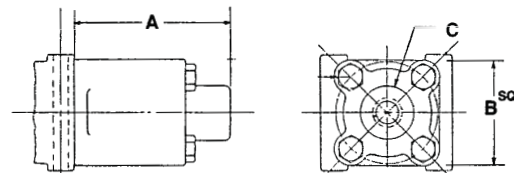

Size	A	B	C
1/4"	3.00	1.65	1/4-18 N.P.T.
1/2"	2.94	1.95	1/4-18 N.P.T.

45 psi (3.1 bar) minimum with spring, 12 psi (0.83 bar) minimum without spring.

Remote pneumatic operation. Must have return spring when used as only operator. When used with another operator it may be used with no return spring or with centering springs. Net Weight: 1/4" - 8 oz. (0.23 Kg.); 1/2" - 8 oz. (0.23 Kg.)

AUTOMATIC DRAIN VALVE - The Pilot Cylinder Operated Type "D" PILOTAIR Valve has been utilized to operate as an automatic drain valve.

1/4" NPT valve = R431003036
1/2" NPT valve = R431007133

“D” Pilotair® Valves

Valve Operator Selections (Operator code numbers shown on page 46)

Dimensions

LOW PRESSURE PILOT CYLINDER

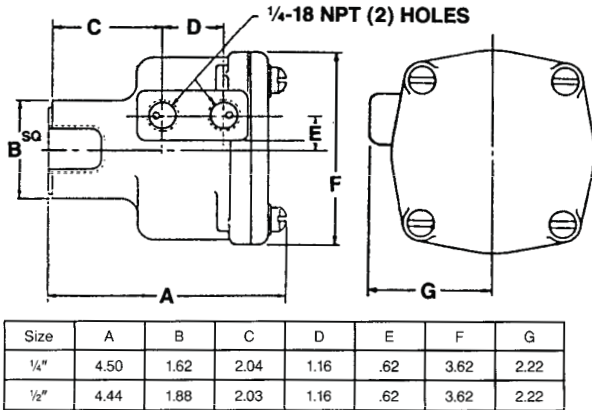

120 psi (8.3 bar) maximum, 9 psi (0.62 bar) minimum with spring, 3 psi (0.21 bar) minimum without spring.

Pneumatically-operated by low control pressure. May have full spring return or be dual-piloted. Either side of pilot piston diaphragm is pressurized to position spool when dual-piloted. May also be used with another operator with no return spring or with centering springs. Net Weight: 1/4" - 1 lb. 13 oz. (0.82 Kg.); 1/2" - 1 lb. 14 oz. (0.85 bar)

RELAY VALVE - The Low Pressure Pilot Cylinder Operated Type “D” PILOTAIR Valve has been utilized as a pressure relay valve. By piping the outlet pressure to the underside of the diaphragm, control air pressure is duplicated in the outlet line. Relay Valves repeat large quantities of air at pressures corresponding with the control pressure applied to them. They are used to increase speed of operation by reducing transmission time and flow requirements in long control lines. For more information see “Accessory Valve” Section, Catalog SC-400.

SOLENOID CONTROLLED OPERATOR*

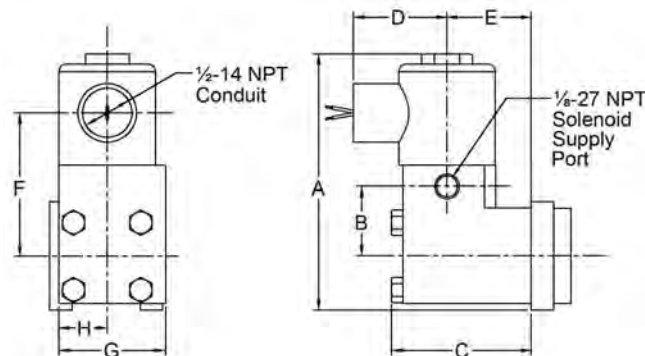

Size	A	B	C	D	E	F	G	H
1/4"	4.36	1.19	2.38	1.58	1.44	2.42	1.83	0.83
1/2"	4.56	1.19	2.31	1.58	1.38	2.50	2.05	0.98

150 psi (6.3 bar) maximum, 45 psi (3.1 bar) minimum with spring, 12 psi (0.83 bar) minimum without spring.

Solenoid controlled air pilot operated uses an external pilot pressure to operate its piston. Pilot port tapped 1/8" NPT and is either connected to the supply port of the valve or to an independent supply pressure. Must have return spring when used as only operator. When used with another operator it may be used with no return spring or with centering springs. Molded weatherproof coils standard. Tabulations on pages 35 thru 41 list 120V and 240V models. Other coil voltages and explosion-proof models available (see pg. 44) Net Weight: 1/4" - 1 lb. 4 oz. (0.57 Kg.); 1/2" - 1 lb. 7 oz. (0.65 Kg.)

END COVER KIT

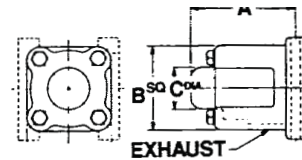

Size	A	B	C
1/4"	1.84	1.65	.81
1/2"	1.81	1.95	.94

Used to protect the open end of a valve from foreign matter or damage and to house return springs when used. Net Weight: 1/4" - 5 oz. (0.14 Kg.); 1/2" - 6 oz. (0.17 Kg.)

DETENT KIT

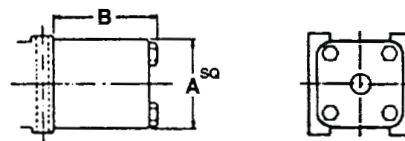

Size	A	B
1/4"	1.75	2.38
1/2"	2.00	2.28

Available for lever and button operators with no return spring. Holds the spook in position in severe vibration application or provides “position-feel”. Available in two - and three-position. Net Weight: 1/4" - 10 oz. (0.28 Kg), 1/2" - 12 oz. (0.34 Kg.)

*Drawing reflects design change effective during 2015, earlier die cast version dimensions are slightly different. Stock of earlier version operators from the factory and distributors will be used for a period of time. For those dimensions, contact factory.

“D” Pilotair[®] Valves
Two-Way Valves-Complete Assembly Model Numbers

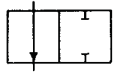

PD2 = 1/4" Valve
 PD4 = 1/2" Valve

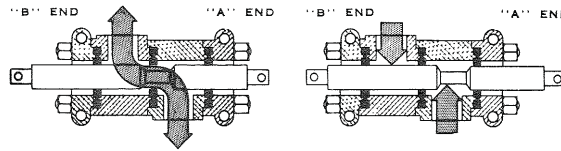

OPERATOR		OPERATOR WITH						
		NO SPRING RETURN			FULL SPRING RETURN			
		No End Cover	With End Cover	With Detent	Normally Open	Normally Closed	No End Cover	With End Cover
LEVER	Push To Open Pull To Close	PD2-20-0001 PD4-20-0001	PD2-20-9801 PD4-20-9801	PD2-20-9001 PD4-20-9001				
LEVER	Pull To Open Push To Close	PD2-20-0100 PD4-20-0100	PD2-20-0198 PD4-20-0198	PD2-20-0190 PD4-20-0190				
LEVER	Push To Operate					PD2-20-0155 PD4-20-0155		PD2-20-5501 PD4-20-5501
LEVER	Pull To Operate				PD2-20-0002 PD4-20-0002	PD2-20-9802 PD4-20-9802	PD2-20-0200 PD4-20-0200	PD2-20-0298 PD4-20-0298
BUTTON	Push To Open Pull To Close	PD2-20-0400 PD4-20-0400	PD2-20-0498 PD4-20-0498	PD2-20-0490 PD4-20-0490				
BUTTON	Pull To Open Push To Close	PD2-20-0004 PD4-20-0004	PD2-20-9804 PD4-20-9804	PD2-20-9004 PD4-20-9004				
BUTTON	Push To Operate				PD2-20-0005 PD4-20-0005	PD2-20-9805 PD4-20-9805	PD2-20-0500 PD4-20-0500	PD2-20-0598 PD4-20-0598
BUTTON	Pull To Operate					PD2-20-0455 PD4-20-0455		PD2-20-5504 PD4-20-5504
BUTTON	Push To Open Pull To Close	PD2-20-8700 PD4-20-8700	PD2-20-8798 PD4-20-8798	PD2-20-8790 PD4-20-8790				
BUTTON	Pull To Open Push To Close	PD2-20-0087 PD4-20-0087	PD2-20-9887 PD4-20-9887	PD2-20-9087 PD4-20-9087				
BUTTON	Push To Operate W/FLANGE				PD2-20-0088 PD4-20-0088	PD2-20-9888 PD4-20-9888	PD2-20-8800 PD4-20-8800	PD2-20-8898 PD4-20-8898
BUTTON	Pull To Operate W/FLANGE					PD2-20-8755 PD4-20-8755		PD2-20-5587 PD4-20-5587
CAM					PD2-20-0008 PD4-20-0008	PD2-20-9808 PD4-20-9808	PD2-20-0800 PD4-20-0800	PD2-20-0898 PD4-20-0898
PILOT CYLINDER					PD2-20-0011 PD4-20-0011	PD2-20-9811 PD4-20-9811	PD2-20-1100 PD4-20-1100	PD2-20-1198 PD4-20-1198
SOLENOID* (120V, 60C)					PD2-20-0014 PD4-20-0014	PD2-20-9814 PD4-20-9814	PD2-20-1400 PD4-20-1400	PD2-20-1498 PD4-20-1498
SOLENOID* (240V, 60C)					PD2-20-0017 PD4-20-0017	PD2-20-9817 PD4-20-9817	PD2-20-1700 PD4-20-1700	PD2-20-1798 PD4-20-1798
FOOT PEDAL					PD2-20-0023 PD4-20-0023	PD2-20-9823 PD4-20-9823	PD2-20-2300 PD4-20-2300	PD2-20-2398 PD4-20-2398
FOOT TREADLE		PD2-20-5200 PD4-20-5200	PD2-20-5298 PD4-20-5298					
LOW PRESSURE PILOT CYLINDER		PD2-20-1900 PD4-20-1900	PD2-20-1998 PD4-20-1998		PD2-20-0020 PD4-20-0020	PD2-20-9820 PD4-20-9820	PD2-20-2000 PD4-20-2000	PD2-20-2098 PD4-20-2098

OPERATOR ON "B" END:	OPERATOR ON "A" END:								
	Lever	Button	Button (with flange mtg.)	Cam	Pilot Cylinder	Solenoid* (115V, 60C.)	Solenoid* (220V, 60C.)	Pedal	Low Pressure Pilot Cylinder
Cam	PD2-20-0107 PD4-20-0107	PD2-20-0407 PD4-20-0407	PD2-20-8707 PD4-20-8707	PD2-20-0707 PD4-20-0707	PD2-20-1007 PD4-20-1007	PD2-20-1307 PD4-20-1307	PD2-20-1607 PD4-20-1607	PD2-20-2207 PD4-20-2207	PD2-20-1907 PD4-20-1907
Pilot Cylinder	PD2-20-0110 PD4-20-0110	PD2-20-0410 PD4-20-0410	PD2-20-8710 PD4-20-8710	PD2-20-0710 PD4-20-0710	PD2-20-1010 PD4-20-1010	PD2-20-1310 PD4-20-1310	PD2-20-1610 PD4-20-1610	PD2-20-2210 PD4-20-2210	PD2-20-1910 PD4-20-1910
Solenoid* (120V, 60C)	PD2-20-0113 PD4-20-0113	PD2-20-0413 PD4-20-0413	PD2-20-8713 PD4-20-8713	PD2-20-0713 PD4-20-0713	PD2-20-1013 PD4-20-1013	PD2-20-1313 PD4-20-1313		PD2-20-2213 PD4-20-2213	PD2-20-1913 PD4-20-1913
Solenoid* (240V, 60C)	PD2-20-0116 PD4-20-0116	PD2-20-0416 PD4-20-0416	PD2-20-8716 PD4-20-8716	PD2-20-0716 PD4-20-0716	PD2-20-1016 PD4-20-1016		PD2-20-1616 PD4-20-1616	PD2-20-2216 PD4-20-2216	PD2-20-1916 PD4-20-1916

*Solenoid controlled, air pilot operated
 †Operator on "A" end, when effective, opens the valve
 ‡Operator on "B" end, when effective, closes the valve

Note: see pages 49-51 for model number cross reference to current part number.

“D” Pilotair® Valves
Three-Way Valves - Open Exhaust - Complete Assembly Model Numbers

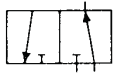

PD2 = 1/4" Valve
 PD4 = 1/2" Valve

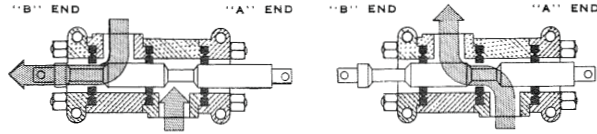

SINGLE OPERATOR

OPERATOR	OPERATOR WITH							
	NO SPRING RETURN			FULL SPRING RETURN				
	No End Cover	With End Cover	With Detent	NORMALLY OPEN		NORMALLY CLOSED		
				No End Cover	With End Cover	No End Cover	With End Cover	
LEVER Push To Open Pull To Close	PD2-31-0001 PD4-31-0001	PD2-31-9801 PD4-31-9801	PD2-31-9001 PD4-31-9001					
LEVER Pull To Open Push To Close	PD2-31-0100 PD4-31-0100	PD2-31-0198 PD4-31-0198	PD2-31-0190 PD4-31-0190					
LEVER Push To Operate					PD2-31-0155 PD4-31-0155		PD2-31-5501 PD4-31-5501	
LEVER Pull To Operate				PD2-31-0002 PD4-31-0002	PD2-31-9802 PD4-31-9802	PD2-31-0200 PD4-31-0200	PD2-31-0298 PD4-31-0298	
BUTTON Push To Open Pull To Close	PD2-31-0400 PD4-31-0400	PD2-31-0498 PD4-31-0498	PD2-31-0490 PD4-31-0490					
BUTTON Pull To Open Push To Close	PD2-31-0004 PD4-31-0004	PD2-31-9804 PD4-31-9804	PD2-31-9004 PD4-31-9004					
BUTTON Push To Operate				PD2-31-0005 PD4-31-0005	PD2-31-9805 PD4-31-9805	PD2-31-0500 PD4-31-0500	PD2-31-0598 PD4-31-0598	
BUTTON Pull To Operate					PD2-31-0455 PD4-31-0455		PD2-31-5504 PD4-31-5504	
BUTTON W FLANGE Push To Open Pull To Close	PD2-31-8700 PD4-31-8700	PD2-31-8798 PD4-31-8798	PD2-31-8790 PD4-31-8790					
BUTTON W FLANGE Pull To Open Push To Close	PD2-31-0087 PD4-31-0087	PD2-31-9887 PD4-31-9887	PD2-31-9087 PD4-31-9087					
BUTTON W FLANGE Push To Operate				PD2-31-0088 PD4-31-0088	PD2-31-9888 PD4-31-9888	PD2-31-8800 PD4-31-8800	PD2-31-8898 PD4-31-8898	
BUTTON W FLANGE Pull To Operate					PD2-31-8755 PD4-31-8755		PD2-31-5587 PD4-31-5587	
CAM				PD2-31-0008 PD4-31-0008	PD2-31-9808 PD4-31-9808	PD2-31-0800 PD4-31-0800	PD2-31-0898 PD4-31-0898	
PILOT CYLINDER				PD2-31-0011 PD4-31-0011	PD2-31-9811 PD4-31-9811	PD2-31-1100 PD4-31-1100	PD2-31-1198 PD4-31-1198	
SOLENOID* (120V, 60C)				PD2-31-0014 PD4-31-0014	PD2-31-9814 PD4-31-9814	PD2-31-1400 PD4-31-1400	PD2-31-1498 PD4-31-1498	
SOLENOID* (240V, 60C)				PD2-31-0017 PD4-31-0017	PD2-31-9817 PD4-31-9817	PD2-31-1700 PD4-31-1700	PD2-31-1798 PD4-31-1798	
FOOT PEDAL				PD2-31-0023 PD4-31-0023	PD2-31-9823 PD4-31-9823	PD2-31-2300 PD4-31-2300	PD2-31-2398 PD4-31-2398	
FOOT TREADLE	PD2-31-5200 PD4-31-5200	PD2-31-5298 PD4-31-5298						
LOW PRESSURE PILOT CYLINDER	PD2-31-1900 PD4-31-1900	PD2-31-1998 PD4-31-1998		PD2-31-0020 PD4-31-0020	PD2-31-9820 PD4-31-9820	PD2-31-2000 PD4-31-2000	PD2-31-2098 PD4-31-2098	

TWO OPERATORS WITH NO SPRING RETURN

OPERATOR ON "B" END:	OPERATOR ON "A" END:								
	Lever	Button	Button (with flange mtg.)	Cam	Pilot Cylinder	Solenoid* (115V., 60C.)	Solenoid* (220V., 60C.)	Pedal	Low Pressure Pilot Cylinder
Cam	PD2-31-0107 PD4-31-0107	PD2-31-0407 PD4-31-0407	PD2-31-8707 PD4-31-8707	PD2-31-0707 PD4-31-0707	PD2-31-1007 PD4-31-1007	PD2-31-1307 PD4-31-1307	PD2-31-1607 PD4-31-1607	PD2-31-2207 PD4-31-2207	PD2-31-1907 PD4-31-1907
Pilot Cylinder	PD2-31-0110 PD4-31-0110	PD2-31-0410 PD4-31-0410	PD2-31-8710 PD4-31-8710	PD2-31-0710 PD4-31-0710	PD2-31-1010 PD4-31-1010	PD2-31-1310 PD4-31-1310	PD2-31-1610 PD4-31-1610	PD2-31-2210 PD4-31-2210	PD2-31-1910 PD4-31-1910
Solenoid* (120V., 60C)	PD2-31-0113 PD4-31-0113	PD2-31-0413 PD4-31-0413	PD2-31-8713 PD4-31-8713	PD2-31-0713 PD4-31-0713	PD2-31-1013 PD4-31-1013	PD2-31-1313 PD4-31-1313		PD2-31-2213 PD4-31-2213	PD2-31-1913 PD4-31-1913
Solenoid* (240V., 60C)	PD2-31-0116 PD4-31-0116	PD2-31-0416 PD4-31-0416	PD2-31-8716 PD4-31-8716	PD2-31-0716 PD4-31-0716	PD2-31-1016 PD4-31-1016		PD2-31-1616 PD4-31-1616	PD2-31-2216 PD4-31-2216	PD2-31-1916 PD4-31-1916

Solenoid controlled, air pilot operated
 †Operator on "A" end, when effective, opens the valve
 ‡Operator on "B" end, when effective, closes the valve and vents outlet

Note: see pages 49-51 for model number cross reference to current part number.

“D” Pilotair[®] Valves
Three-Way Valves - Tapped Exhaust - Complete Assembly Model Numbers

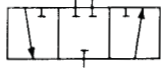

CLOSED CENTER POSITION

PD2 = 1/4" Valve
 PD4 = 1/2" Valve

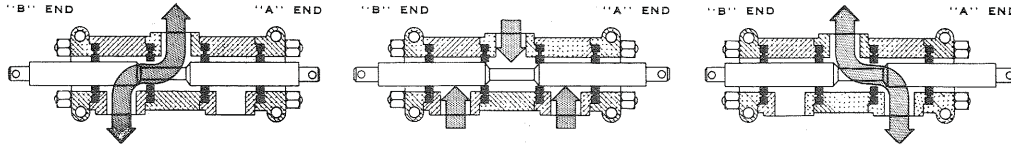

SINGLE OPERATOR

OPERATOR	OPERATOR WITH					CENTERING SPRINGS
	NO SPRING RETURN			FULL SPRING RETURN		
	No End Cover	With End Cover	With Detent †	No End Cover	With End Cover	
Lever	PD2 32-0100 PD4 32-0100	PD2 32-0198 PD4 32-0198	PD2 32-0191 PD4 32-0191	PD2 32-0002 PD4 32-0002	PD2 32-9802 PD4 32-9802	PD2 32-0354 PD4 32-0354
Button	PD2 32-0400 PD4 32-0400	PD2 32-0498 PD4 32-0498	PD2 32-0491 PD4 32-0491	PD2 32-0500 PD4 32-0500	PD2 32-0598 PD4 32-0598	PD2 32-0654 PD4 32-0654
Button (with flange mounting)	PD2 32-8700 PD4 32-8700	PD2 32-8798 PD4 32-8798	PD2 32-8791 PD4 32-8791	PD2 32-8800 PD4 32-8800	PD2 32-8898 PD4 32-8898	PD2 32-8954 PD4 32-8954
Cam				PD2 32-0800 PD4 32-0800	PD2 32-0898 PD4 32-0898	
Pilot Cylinder				PD2 32-1100 PD4 32-1100	PD2 32-1198 PD4 32-1198	
Solenoid* (120V., 60C)				PD2 32-1400 PD4 32-1400	PD2 32-1498 PD4 32-1498	
Solenoid* (240V., 60C)				PD2 32-1700 PD4 32-1700	PD2 32-1798 PD4 32-1798	
Foot Pedal				PD2 32-2300 PD4 32-2300	PD2 32-2398 PD4 32-2398	
Foot Treadle	PD2 32-5200 PD4 32-5200	PD2 32-5298 PD4 32-5298				PD2 32-5354 PD4 32-5354
Low Pressure Pilot Cylinder	PD2 32-1900 PD4 32-1900	PD2 32-1998 PD4 32-1998		PD2 32-2000 PD4 32-2000	PD2 32-2098 PD4 32-2098	PD2 32-2154 PD4 32-2154

TWO OPERATORS WITH CENTERING SPRINGS

OPERATOR ON "B" END	OPERATOR ON "A" END							
	Lever	Button	Button (with flange mtg.)	Cam	Pilot Cylinder	Solenoid* (115V., 60C)	Solenoid* (220V., 60C)	Low Pressure Pilot Cylinder
Cam	PD2 32-0309 PD4 32-0309	PD2 32-0609 PD4 32-0609	PD2 32-8909 PD4 32-8909	PD2 32-0909 PD4 32-0909	PD2 32-1209 PD4 32-1209	PD2 32-1509 PD4 32-1509	PD2 32-1809 PD4 32-1809	PD2 32-2109 PD4 32-2109
Pilot Cylinder	PD2 32-0312 PD4 32-0312	PD2 32-0612 PD4 32-0612	PD2 32-8912 PD4 32-8912	PD2 32-0912 PD4 32-0912	PD2 32-1212 PD4 32-1212	PD2 32-1512 PD4 32-1512	PD2 32-1812 PD4 32-1812	PD2 32-2112 PD4 32-2112
Solenoid* (120V., 60C)	PD2 32-0315 PD4 32-0315	PD2 32-0615 PD4 32-0615	PD2 32-8915 PD4 32-8915	PD2 32-0915 PD4 32-0915	PD2 32-1215 PD4 32-1215	PD2 32-1515 PD4 32-1515		PD2 32-2115 PD4 32-2115
Solenoid* (240V., 60C)	PD2 32-0318 PD4 32-0318	PD2 32-0618 PD4 32-0618	PD2 32-8918 PD4 32-8918	PD2 32-0918 PD4 32-0918	PD2 32-1218 PD4 32-1218		PD2 32-1818 PD4 32-1818	PD2 32-2118 PD4 32-2118

TWO OPERATORS WITH NO SPRING RETURN

OPERATOR ON "B" END	OPERATOR ON "A" END								
	Lever	Button	Button (with flange mtg.)	Cam	Pilot Cylinder	Solenoid* (115V., 60C)	Solenoid* (220V., 60C)	Pedal	Low Pressure Pilot Cylinder
Cam	PD2 32-0107 PD4 32-0107	PD2 32-0407 PD4 32-0407	PD2 32-8707 PD4 32-8707	PD2 32-0707 PD4 32-0707	PD2 32-1007 PD4 32-1007	PD2 32-1307 PD4 32-1307	PD2 32-1607 PD4 32-1607	PD2 32-2207 PD4 32-2207	PD2 32-1907 PD4 32-1907
Pilot Cylinder	PD2 32-0110 PD4 32-0110	PD2 32-0410 PD4 32-0410	PD2 32-8710 PD4 32-8710	PD2 32-0710 PD4 32-0710	PD2 32-1010 PD4 32-1010	PD2 32-1310 PD4 32-1310	PD2 32-1610 PD4 32-1610	PD2 32-2210 PD4 32-2210	PD2 32-1910 PD4 32-1910
Solenoid* (120V., 60C)	PD2 32-0113 PD4 32-0113	PD2 32-0413 PD4 32-0413	PD2 32-8713 PD4 32-8713	PD2 32-0713 PD4 32-0713	PD2 32-1013 PD4 32-1013	PD2 32-1313 PD4 32-1313		PD2 32-2213 PD4 32-2213	PD2 32-1913 PD4 32-1913
Solenoid* (240V., 60C)	PD2 32-0116 PD4 32-0116	PD2 32-0416 PD4 32-0416	PD2 32-8716 PD4 32-8716	PD2 32-0716 PD4 32-0716	PD2 32-1016 PD4 32-1016		PD2 32-1616 PD4 32-1616	PD2 32-2216 PD4 32-2216	PD2 32-1916 PD4 32-1916

*Solenoid controlled, air pilot operated
 †Three-position detent

Note: see pages 49-51 for model number cross reference to current part number.

“D” Pilotair® Valves
Four-Way Valves - Open Exhaust - Closed Center
Complete Assembly Model Numbers

PD2 = 1/4" Valve
 PD4 = 1/2" Valve

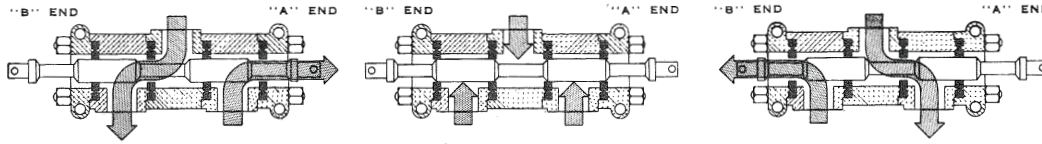

SINGLE OPERATOR

OPERATOR	OPERATOR WITH					
	NO SPRING RETURN			FULL SPRING RETURN		CENTERING SPRINGS
	No End Cover	With End Cover	With Detent†	No End Cover	With End Cover	
Lever	PD2-41-0100 PD4-41-0100	PD2-41-0198 PD4-41-0198	PD2-41-0191 PD4-41-0191	PD2-41-0002 PD4-41-0002	PD2-41-9802 PD4-41-9802	PD2-41-0354 PD4-41-0354
Button	PD2-41-0400 PD4-41-0400	PD2-41-0498 PD4-41-0498	PD2-41-0491 PD4-41-0491	PD2-41-0500 PD4-41-0500	PD2-41-0598 PD4-41-0598	PD2-41-0654 PD4-41-0654
Button (with flange mounting)	PD2-41-8700 PD4-41-8700	PD2-41-8798 PD4-41-8798	PD2-41-8791 PD4-41-8791	PD2-41-8800 PD4-41-8800	PD2-41-8898 PD4-41-8898	PD2-41-8954 PD4-41-8954
Cam				PD2-41-0800 PD4-41-0800	PD2-41-0898 PD4-41-0898	
Pilot Cylinder				PD2-41-1100 PD4-41-1100	PD2-41-1198 PD4-41-1198	
Solenoid* (120V, 60C)				PD2-41-1400 PD4-41-1400	PD2-41-1498 PD4-41-1498	
Solenoid* (240V, 60C)				PD2-41-1700 PD4-41-1700	PD2-41-1798 PD4-41-1798	
Foot Pedal				PD2-41-2300 PD4-41-2300	PD2-41-2398 PD4-41-2398	
Foot Treadle	PD2-41-5200 PD4-41-5200	PD2-41-5298 PD4-41-5298				PD2-41-5354 PD4-41-5354
Low Pressure Pilot Cylinder	PD2-41-1900 PD4-41-1900	PD2-41-1998 PD4-41-1998		PD2-41-2000 PD4-41-2000	PD2-41-2098 PD4-41-2098	PD2-41-2154 PD4-41-2154

TWO OPERATORS WITH CENTERING SPRINGS

OPERATOR ON "B" END	OPERATOR ON "A" END							
	Lever	Button	Button (with flange mtg.)	Cam	Pilot Cylinder	Solenoid* (115V, 60C.)	Solenoid* (220V, 60C.)	Low Pressure Pilot Cylinder
Cam	PD2-41-0309 PD4-41-0309	PD2-41-0609 PD4-41-0609	PD2-41-8909 PD4-41-8909	PD2-41-0909 PD4-41-0909	PD2-41-1209 PD4-41-1209	PD2-41-1509 PD4-41-1509	PD2-41-1809 PD4-41-1809	PD2-41-2109 PD4-41-2109
Pilot Cylinder	PD2-41-0312 PD4-41-0312	PD2-41-0612 PD4-41-0612	PD2-41-8912 PD4-41-8912	PD2-41-0912 PD4-41-0912	PD2-41-1212 PD4-41-1212	PD2-41-1512 PD4-41-1512	PD2-41-1812 PD4-41-1812	PD2-41-2112 PD4-41-2112
Solenoid* (120V, 60C)	PD2-41-0315 PD4-41-0315	PD2-41-0615 PD4-41-0615	PD2-41-8915 PD4-41-8915	PD2-41-0915 PD4-41-0915	PD2-41-1215 PD4-41-1215	PD2-41-1515 PD4-41-1515		PD2-41-2115 PD4-41-2115
Solenoid* (240V, 60C)	PD2-41-0318 PD4-41-0318	PD2-41-0618 PD4-41-0618	PD2-41-8918 PD4-41-8918	PD2-41-0918 PD4-41-0918	PD2-41-1218 PD4-41-1218		PD2-41-1818 PD4-41-1818	PD2-41-2118 PD4-41-2118

TWO OPERATORS WITH NO SPRING RETURN

OPERATOR ON "B" END	OPERATOR ON "A" END								
	Lever	Button	Button (with flange mtg.)	Cam	Pilot Cylinder	Solenoid* (115V, 60C.)	Solenoid* (220V, 60C.)	Pedal	Low Pressure Pilot Cylinder
Cam	PD2-41-0107 PD4-41-0107	PD2-41-0407 PD4-41-0407	PD2-41-8707 PD4-41-8707	PD2-41-0707 PD4-41-0707	PD2-41-1007 PD4-41-1007	PD2-41-1307 PD4-41-1307	PD2-41-1607 PD4-41-1607	PD2-41-2207 PD4-41-2207	PD2-41-1907 PD4-41-1907
Pilot Cylinder	PD2-41-0110 PD4-41-0110	PD2-41-0410 PD4-41-0410	PD2-41-8710 PD4-41-8710	PD2-41-0710 PD4-41-0710	PD2-41-1010 PD4-41-1010	PD2-41-1310 PD4-41-1310	PD2-41-1610 PD4-41-1610	PD2-41-2210 PD4-41-2210	PD2-41-1910 PD4-41-1910
Solenoid* (120V, 60C)	PD2-41-0113 PD4-41-0113	PD2-41-0413 PD4-41-0413	PD2-41-8713 PD4-41-8713	PD2-41-0713 PD4-41-0713	PD2-41-1013 PD4-41-1013	PD2-41-1313 PD4-41-1313		PD2-41-2213 PD4-41-2213	PD2-41-1913 PD4-41-1913
Solenoid* (240V, 60C)	PD2-41-0116 PD4-41-0116	PD2-41-0416 PD4-41-0416	PD2-41-8716 PD4-41-8716	PD2-41-0716 PD4-41-0716	PD2-41-1016 PD4-41-1016		PD2-41-1616 PD4-41-1616	PD2-41-2216 PD4-41-2216	PD2-41-1916 PD4-41-1916

*Solenoid controlled, air pilot operated
 †Three-position detent

Note: see pages 49-51 for model number cross reference to current part number.

“D” Pilotair[®] Valves
Four-Way Valves - Tapped Exhaust - Closed Center
Complete Assembly Model Numbers

PD2 = 1/4" Valve
 PD4 = 1/2" Valve

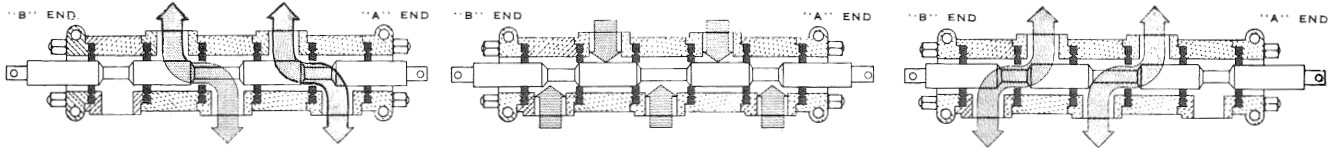

SINGLE OPERATOR

OPERATOR	OPERATOR WITH					
	NO SPRING RETURN			FULL SPRING RETURN		CENTERING SPRINGS
	No End Cover	With End Cover	With Detent †	No End Cover	With End Cover	
Lever	PD2-42-0100 PD4-42-0100	PD2-42-0198 PD4-42-0198	PD2-42-0191 PD4-42-0191	PD2-42-0002 PD4-42-0002	PD2-42-9802 PD4-42-9802	PD2-42-0354 PD4-42-0354
Button	PD2-42-0400 PD4-42-0400	PD2-42-0498 PD4-42-0498	PD2-42-0491 PD4-42-0491	PD2-42-0500 PD4-42-0500	PD2-42-0598 PD4-42-0598	PD2-42-0654 PD4-42-0654
Button (with flange mounting)	PD2-42-8700 PD4-42-8700	PD2-42-8798 PD4-42-8798	PD2-42-8791 PD4-42-8791	PD2-42-8800 PD4-42-8800	PD2-42-8898 PD4-42-8898	PD2-42-8954 PD4-42-8954
Cam				PD2-42-0800 PD4-42-0800	PD2-42-0898 PD4-42-0898	
Pilot Cylinder				PD2-42-1100 PD4-42-1100	PD2-42-1198 PD4-42-1198	
Solenoid* (120V.,60C)				PD2-42-1400 PD4-42-1400	PD2-42-1498 PD4-42-1498	
Solenoid* (240V.,60C)				PD2-42-1700 PD4-42-1700	PD2-42-1798 PD4-42-1798	
Foot Pedal				PD2-42-2300 PD4-42-2300	PD2-42-2398 PD4-42-2398	
Foot Treadle	PD2-42-5200 PD4-42-5200	PD2-42-5298 PD4-42-5298				PD2-42-5354 PD4-42-5354
Low Pressure Pilot Cylinder	PD2-42-1900 PD4-42-1900	PD2-42-1998 PD4-42-1998		PD2-42-2000 PD4-42-2000	PD2-42-2098 PD4-42-2098	PD2-42-2154 PD4-42-2154

TWO OPERATORS WITH CENTERING SPRINGS

OPERATOR ON "B" END	OPERATOR ON "A" END							
	Lever	Button	Button (with flange mtg.)	Cam	Pilot Cylinder	Solenoid* (115V., 60C.)	Solenoid* (220V., 60C.)	Low Pressure Pilot Cylinder
Cam	PD2-42-0309 PD4-42-0309	PD2-42-0609 PD4-42-0609	PD2-42-8909 PD4-42-8909	PD2-42-0909 PD4-42-0909	PD2-42-1209 PD4-42-1209	PD2-42-1509 PD4-42-1509	PD2-42-1809 PD4-42-1809	PD2-42-2109 PD4-42-2109
Pilot Cylinder	PD2-42-0312 PD4-42-0312	PD2-42-0612 PD4-42-0612	PD2-42-8912 PD4-42-8912	PD2-42-0912 PD4-42-0912	PD2-42-1212 PD4-42-1212	PD2-42-1512 PD4-42-1512	PD2-42-1812 PD4-42-1812	PD2-42-2112 PD4-42-2112
Solenoid* (120V.,60C)	PD2-42-0315 PD4-42-0315	PD2-42-0615 PD4-42-0615	PD2-42-8915 PD4-42-8915	PD2-42-0915 PD4-42-0915	PD2-42-1215 PD4-42-1215	PD2-42-1515 PD4-42-1515		PD2-42-2115 PD4-42-2115
Solenoid* (240V.,60C)	PD2-42-0318 PD4-42-0318	PD2-42-0618 PD4-42-0618	PD2-42-8918 PD4-42-8918	PD2-42-0918 PD4-42-0918	PD2-42-1218 PD4-42-1218		PD2-42-1818 PD4-42-1818	PD2-42-2118 PD4-42-2118

TWO OPERATORS WITH NO SPRING RETURN

OPERATOR ON "B" END	OPERATOR ON "A" END								
	Lever	Button	Button (with flange mtg.)	Cam	Pilot Cylinder	Solenoid* (115V., 60C.)	Solenoid* (220V., 60C.)	Pedal	Low Pressure Pilot Cylinder
Cam	PD2-42-0107 PD4-42-0107	PD2-42-0407 PD4-42-0407	PD2-42-8707 PD4-42-8707	PD2-42-0707 PD4-42-0707	PD2-42-1007 PD4-42-1007	PD2-42-1307 PD4-42-1307	PD2-42-1607 PD4-42-1607	PD2-42-2207 PD4-42-2207	PD2-42-1907 PD4-42-1907
Pilot Cylinder	PD2-42-0110 PD4-42-0110	PD2-42-0410 PD4-42-0410	PD2-42-8710 PD4-42-8710	PD2-42-0710 PD4-42-0710	PD2-42-1010 PD4-42-1010	PD2-42-1310 PD4-42-1310	PD2-42-1610 PD4-42-1610	PD2-42-2210 PD4-42-2210	PD2-42-1910 PD4-42-1910
Solenoid* (120V.,60C)	PD2-42-0113 PD4-42-0113	PD2-42-0413 PD4-42-0413	PD2-42-8713 PD4-42-8713	PD2-42-0713 PD4-42-0713	PD2-42-1013 PD4-42-1013	PD2-42-1313 PD4-42-1313		PD2-42-2213 PD4-42-2213	PD2-42-1913 PD4-42-1913
Solenoid* (240V.,60C)	PD2-42-0116 PD4-42-0116	PD2-42-0416 PD4-42-0416	PD2-42-8716 PD4-42-8716	PD2-42-0716 PD4-42-0716	PD2-42-1016 PD4-42-1016		PD2-42-1616 PD4-42-1616	PD2-42-2216 PD4-42-2216	PD2-42-1916 PD4-42-1916

*Solenoid controlled, air pilot operated
 †Three-position detent

Note: see pages 49-51 for model number cross reference to current part number.

“D” Pilotair® Valves
Four-Way Valves - Open Exhaust - Exhaust Center
Complete Assembly Model Numbers

PD2 = 1/4" Valve
 PD4 = 1/2" Valve

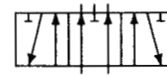

EXHAUST CENTER POSITION

SINGLE OPERATOR

OPERATOR	OPERATOR WITH	
	No Spring Return	Centering Springs
	With Detent†	
Lever	PD2 43 0191 PD4 43 0191	PD2 43 0354 PD4 43 0354
Button	PD2 43 0491 PD4 43 0491	PD2 43 0654 PD4 43 0654
Button (with flange mounting)	PD2 43 8791 PD4 43 8791	PD2 43 8954 PD4 43 8954
Foot Treadle		PD2 43 5354 PD4 43 5354
Low Pressure Pilot Cylinder		PD2 43 2154 PD4 43 2154

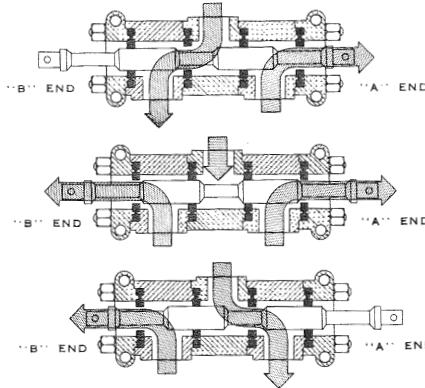

TWO OPERATORS WITH CENTERING SPRINGS

OPERATOR ON "B" END	OPERATOR ON "A" END							
	Lever	Button	Button (with flange mtg.)	Cam	Pilot Cylinder	Solenoid* (115V., 60C.)	Solenoid* (220V., 60C.)	Low Pressure Pilot Cylinder
Cam	PD2 43 0309 PD4 43 0309	PD2 43 0609 PD4 43 0609	PD2 43 8909 PD4 43 8909	PD2 43 0909 PD4 43 0909	PD2 43 1209 PD4 43 1209	PD2 43 1509 PD4 43 1509	PD2 43 1809 PD4 43 1809	PD2 43 2109 PD4 43 2109
Pilot Cylinder	PD2 43 0312 PD4 43 0312	PD2 43 0612 PD4 43 0612	PD2 43 8912 PD4 43 8912	PD2 43 0912 PD4 43 0912	PD2 43 1212 PD4 43 1212	PD2 43 1512 PD4 43 1512	PD2 43 1812 PD4 43 1812	PD2 43 2112 PD4 43 2112
Solenoid* (120V., 60C.)	PD2 43 0315 PD4 43 0315	PD2 43 0615 PD4 43 0615	PD2 43 8915 PD4 43 8915	PD2 43 0915 PD4 43 0915	PD2 43 1215 PD4 43 1215	PD2 43 1515 PD4 43 1515		PD2 43 2115 PD4 43 2115
Solenoid* (240V., 60C.)	PD2 43 0318 PD4 43 0318	PD2 43 0618 PD4 43 0618	PD2 43 8918 PD4 43 8918	PD2 43 0918 PD4 43 0918	PD2 43 1218 PD4 43 1218		PD2 43 1818 PD4 43 1818	PD2 43 2118 PD4 43 2118

FOUR-WAY VALVES - OPEN EXHAUST - SUPPLIED CENTER
COMPLETE ASSEMBLY PIECE NUMBERS

SINGLE OPERATOR

OPERATOR	OPERATOR WITH	
	No Spring Return	Centering Springs
	With Detent†	
Lever	PD2 45 0191 PD4 45 0191	PD2 45 0354 PD4 45 0354
Button	PD2 45 0491 PD4 45 0491	PD2 45 0654 PD4 45 0654
Button (with flange mounting)	PD2 45 8791 PD4 45 8791	PD2 45 8954 PD4 45 8954
Foot Treadle		PD2 45 5354 PD4 45 5354
Low Pressure Pilot Cylinder		PD2 45 2154 PD4 45 2154

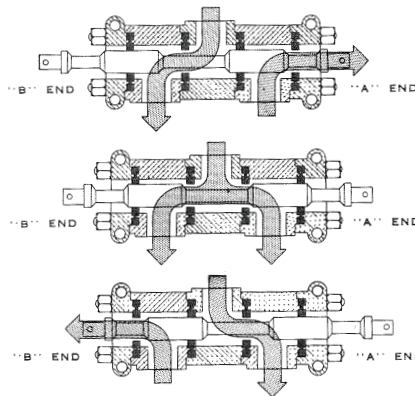

OPEN CENTER POSITION

TWO OPERATORS WITH CENTERING SPRINGS

OPERATOR ON "B" END	OPERATOR ON "A" END							
	Lever	Button	Button (with flange mtg.)	Cam	Pilot Cylinder	Solenoid* (115V., 60C.)	Solenoid* (220V., 60C.)	Low Pressure Pilot Cylinder
Cam	PD2 45 0309 PD4 45 0309	PD2 45 0609 PD4 45 0609	PD2 45 8909 PD4 45 8909	PD2 45 0909 PD4 45 0909	PD2 45 1209 PD4 45 1209	PD2 45 1509 PD4 45 1509	PD2 45 1809 PD4 45 1809	PD2 45 2109 PD4 45 2109
Pilot Cylinder	PD2 45 0312 PD4 45 0312	PD2 45 0612 PD4 45 0612	PD2 45 8912 PD4 45 8912	PD2 45 0912 PD4 45 0912	PD2 45 1212 PD4 45 1212	PD2 45 1512 PD4 45 1512	PD2 45 1812 PD4 45 1812	PD2 45 2112 PD4 45 2112
Solenoid* (120V., 60C.)	PD2 45 0315 PD4 45 0315	PD2 45 0615 PD4 45 0615	PD2 45 8915 PD4 45 8915	PD2 45 0915 PD4 45 0915	PD2 45 1215 PD4 45 1215	PD2 45 1515 PD4 45 1515		PD2 45 2115 PD4 45 2115
Solenoid* (240V., 60C.)	PD2 45 0318 PD4 45 0318	PD2 45 0618 PD4 45 0618	PD2 45 8918 PD4 45 8918	PD2 45 0918 PD4 45 0918	PD2 45 1218 PD4 45 1218		PD2 45 1818 PD4 45 1818	PD2 45 2118 PD4 45 2118

* Solenoid controlled, air pilot operated
 † Three-position detent

Note: see pages 49-51 for model number cross reference to current part number.

“D” Pilotair[®] Valves
Four-Way Valves - Tapped Exhaust - Exhaust Center
Complete Assembly Model Numbers

PD2 = 1/4" Valve
 PD4 = 1/2" Valve

EXHAUST CENTER POSITION

SINGLE OPERATOR

OPERATOR	OPERATOR WITH	
	No Spring Return With Detent†	Centering Springs
Lever	PD2-44-0191 PD4-44-0191	PD2-44-0354 PD4-44-0354
Button	PD2-44-0491 PD4-44-0491	PD2-44-0654 PD4-44-0654
Button (with flange mounting)	PD2-44-8791 PD4-44-8791	PD2-44-8954 PD4-44-8954
Foot Treadle		PD2-44-5354 PD4-44-5354
Low Pressure Pilot Cylinder		PD2-44-2154 PD4-44-2154

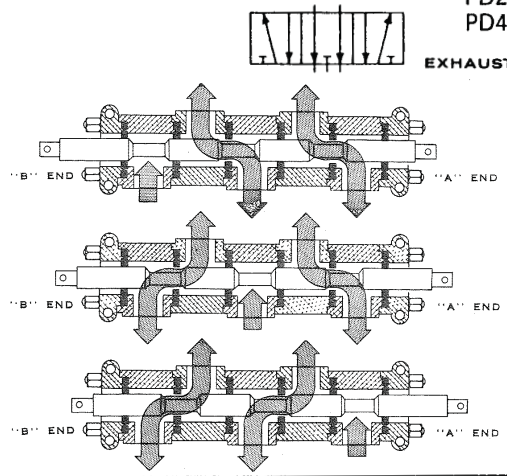

TWO OPERATORS WITH CENTERING SPRINGS

OPERATOR ON "B" END	OPERATOR ON "A" END							
	Lever	Button	Button (with flange mtg.)	Cam	Pilot Cylinder	Solenoid* (115V., 60C.)	Solenoid* (220V., 60C.)	Low Pressure Pilot Cylinder
Cam	PD2-44-0309 PD4-44-0309	PD2-44-0609 PD4-44-0609	PD2-44-8909 PD4-44-8909	PD2-44-0909 PD4-44-0909	PD2-44-1209 PD4-44-1209	PD2-44-1509 PD4-44-1509	PD2-44-1809 PD4-44-1809	PD2-44-2109 PD4-44-2109
Pilot Cylinder	PD2-44-0312 PD4-44-0312	PD2-44-0612 PD4-44-0612	PD2-44-8912 PD4-44-8912	PD2-44-0912 PD4-44-0912	PD2-44-1212 PD4-44-1212	PD2-44-1512 PD4-44-1512	PD2-44-1812 PD4-44-1812	PD2-44-2112 PD4-44-2112
Solenoid* (120V., 60C.)	PD2-44-0315 PD4-44-0315	PD2-44-0615 PD4-44-0615	PD2-44-8915 PD4-44-8915	PD2-44-0915 PD4-44-0915	PD2-44-1215 PD4-44-1215	PD2-44-1515 PD4-44-1515		PD2-44-2115 PD4-44-2115
Solenoid* (240V., 60C.)	PD2-44-0318 PD4-44-0318	PD2-44-0618 PD4-44-0618	PD2-44-8918 PD4-44-8918	PD2-44-0918 PD4-44-0918	PD2-44-1218 PD4-44-1218		PD2-44-1818 PD4-44-1818	PD2-44-2118 PD4-44-2118

FOUR-WAY VALVES - TAPPED EXHAUST - SUPPLIED CENTER
COMPLETE ASSEMBLY PIECE NUMBERS

OPEN CENTER POSITION

SINGLE OPERATOR

OPERATOR	OPERATOR WITH	
	No Spring Return With Detent†	Centering Springs
Lever	PD2-46-0191 PD4-46-0191	PD2-46-0354 PD4-46-0354
Button	PD2-46-0491 PD4-46-0491	PD2-46-0654 PD4-46-0654
Button (with flange mounting)	PD2-46-8791 PD4-46-8791	PD2-46-8954 PD4-46-8954
Foot Treadle		PD2-46-5354 PD4-46-5354
Low Pressure Pilot Cylinder		PD2-46-2154 PD4-46-2154

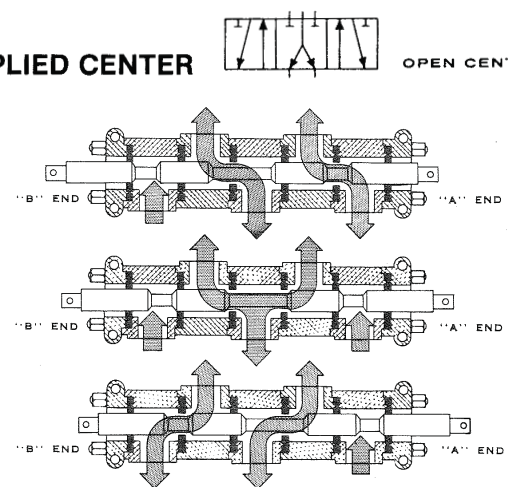

TWO OPERATORS WITH CENTERING SPRINGS

OPERATOR ON "B" END	OPERATOR ON "A" END							
	Lever	Button	Button (with flange mtg.)	Cam	Pilot Cylinder	Solenoid* (115V., 60C.)	Solenoid* (220V., 60C.)	Low Pressure Pilot Cylinder
Cam	PD2-46-0309 PD4-46-0309	PD2-46-0609 PD4-46-0609	PD2-46-8909 PD4-46-8909	PD2-46-0909 PD4-46-0909	PD2-46-1209 PD4-46-1209	PD2-46-1509 PD4-46-1509	PD2-46-1809 PD4-46-1809	PD2-46-2109 PD4-46-2109
Pilot Cylinder	PD2-46-0312 PD4-46-0312	PD2-46-0612 PD4-46-0612	PD2-46-8912 PD4-46-8912	PD2-46-0912 PD4-46-0912	PD2-46-1212 PD4-46-1212	PD2-46-1512 PD4-46-1512	PD2-46-1812 PD4-46-1812	PD2-46-2112 PD4-46-2112
Solenoid* (120V., 60C.)	PD2-46-0315 PD4-46-0315	PD2-46-0615 PD4-46-0615	PD2-46-8915 PD4-46-8915	PD2-46-0915 PD4-46-0915	PD2-46-1215 PD4-46-1215	PD2-46-1515 PD4-46-1515		PD2-46-2115 PD4-46-2115
Solenoid* (240V., 60C.)	PD2-46-0318 PD4-46-0318	PD2-46-0618 PD4-46-0618	PD2-46-8918 PD4-46-8918	PD2-46-0918 PD4-46-0918	PD2-46-1218 PD4-46-1218		PD2-46-1818 PD4-46-1818	PD2-46-2118 PD4-46-2118

*Solenoid controlled, air pilot operated
 †Three-position detent

Note: see pages 49-51 for model number cross reference to current part number.

**“D” Pilotair® Valves
Model Codes For Valves Not Tabulated**

EXAMPLE OF MODEL NUMBER SELECTION

BASIC VALVE: “PD-0” plus 5 digits (Ex: Four way, open exhaust)

“A” End Operator - 2 digit suffix (Lever with no return spring)

“B” End Operator - 2 digit suffix (Solenoid, full return spring)

Use for ordering prepped solenoid valve - see below.

“00” indicates no solenoid piping.

Porting (Ex: 1/2" NPT)
 PD-02 =1/4" NPT
 PD-04 =1/2" NPT
 PD-05 =1/4" BSPP
 PD-07 =1/2" BSPP

PD-040041-0 0114

Select the Basic Valve Portion as shown below, add the desired Operator Kits [which must be coded in the suffix (see example above) when Factory assembly is desired.]

NOTE: SAE or other special porting available by request - consult factory.



BASIC VALVES (WITH SOLENOID PIPING AS SHOWN)

VIEW	VALVE TYPE	CODE NO.	1/4" PART NO.	1/2" PART NO.
A	Two-way valve	120	PD-020120-00000	PD-040120-00000
A	Three-way, open exhaust	131	PD-020131-00000	PD-040131-00000
E	Three-way, tapped exhaust	232	PD-020232-00000	PD-040232-00000
B	Two-way valve	320	PD-020320-00000	PD-040320-00000
B	Three-way, open exhaust	331	PD-020331-00000	PD-040331-00000
F	Three-way, tapped exhaust	432	PD-020432-00000	PD-040432-00000
C	Four-way, open exhaust, closed center	541	PD-020541-00000	PD-040541-00000
C	Four-way, open exhaust, exhaust center	543	PD-020543-00000	PD-040543-00000
C	Four-way, open exhaust, supplied center	545	PD-020545-00000	PD-040545-00000
D	Four-way, open exhaust, closed center	641	PD-020641-00000	PD-040641-00000
D	Four-way, open exhaust, exhaust center	643	PD-020643-00000	PD-040643-00000
D	Four-way, open exhaust, supplied center	645	PD-020645-00000	PD-040645-00000
G	Four-way, tapped exhaust, closed center	742	PD-020742-00000	PD-040742-00000
G	Four-way tapped, exhaust, exhaust center	744	PD-020744-00000	PD-040744-00000
G	Four-way tapped, exhaust, supplied center	746	PD-020746-00000	PD-040746-00000
H	Four-way tapped, exhaust, closed center	842	PD-020842-00000	PD-040842-00000
H	Four-way tapped, exhaust, exhaust center	844	PD-020844-00000	PD-040844-00000
H	Four-way tapped, exhaust, supplied center	846	PD-020846-00000	PD-040846-00000

VIEW	DESCRIPTION	CODE NUMBER	
		1/4"	1/2"
A	Two-way valve	PD-020020	PD-040020
A	Three-way, open exhaust	PD-020031	PD-040031
B	Three-way, tapped exhaust	PD-020032	PD-040032
B	Four-way, open exhaust, closed center	PD-020041	PD-040041
C	Four-way, tapped exhaust, closed center	PD-020042	PD-040042
B	Four-way, open exhaust, exhaust center	PD-020043	PD-040043
C	Four-way, tapped exhaust, exhaust center	PD-020044	PD-040044
B	Four-way, open exhaust, supplied center	PD-020045	PD-040045
C	Four-way, tapped exhaust, supplied center	PD-020046	PD-040046

BASIC VALVE - Solenoid operators with pilot pressure piping.

Select the Basic Valve Portion as shown below, add the desired Solenoid Operator Kits (which must be coded in the suffix when Factory assembly is desired).

SINGLE SOLENOID VALVES DOUBLE SOLENOID VALVES SINGLE SOLENOID VALVES DOUBLE SOLENOID VALVES

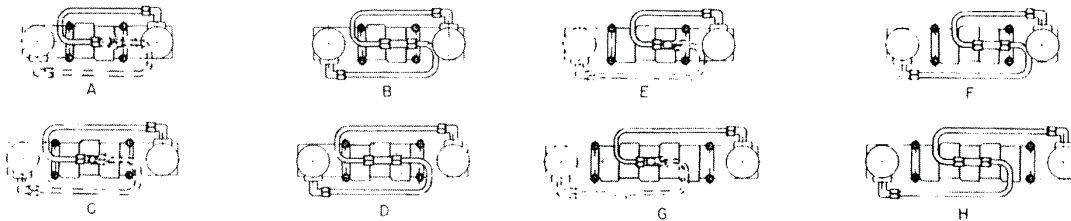

The Basic Valve for a Piped Solenoid Operator has the special tapped body segment already assembled in the valve; Shaded areas indicate material furnished. Tubing is cut to length and formed and fittings are furnished, but tubing and fittings are not assembled to the valve. Dotted lines indicate alternate piping arrangement (the alternate tube, when required, is provided), depending on the location of the solenoid operator. The Basic Valve will be furnished less operators when suffix is not coded.

Note: see pages 49-51 for model number cross reference to current part number.

“D” Pilotair® Pneumatic Directional Control Valves

Operator selection codes

DESCRIPTION	SEE NOTE NO.	CODE NO.
Lever, No Spring Return	-	01
Lever, Full Return Spring	2	02
Lever with Centering Spring	3	03
Button, No Spring Return	-	04
Button, Full Return Spring	2	05
Button with Centering Spring	3	06
Cam, No Spring Return	4	07
Cam, Full Return Spring	2	08
Cam with Centering Spring	5	09
Pilot Cylinder, No Spring Return	4	10
Pilot Cylinder, Full Return Spring	2	11
Pilot Cylinder with Centering Spring	5	12
Solenoid (120V, 60 Cycle), No Return Spring	4	13
Solenoid (120V, 60 Cycle), Full Return Spring	2	14
Solenoid (120V, 60 Cycle), with Centering Spring	5	15
Solenoid (240V, 60 Cycle), No Return Spring	4	16
Solenoid (240V, 60 Cycle), Full Return Spring	2	17
Solenoid (240V, 60 Cycle), with Centering Spring	5	18
Pilot Cylinder (Low Pressure), No Spring Return	6	19
Pilot Cylinder (Low Pressure), Full Return Spring	2	20
Pilot Cylinder (Low Pressure) with Centering Spring	5 & 6	21
Foot Pedal, No Spring Return	4	22
Foot Pedal, Full Return Spring	2	23
Nose Mount, Spring Return	2 & 7	36
Nose Mount, 2-Position Detent	7	37
Nose Mount, 3-Position Detent	7	38
Foot Treadle, No Spring Return	-	52
Foot Treadle with Centering Spring	3	53
End Cover with Centering Spring	4	54
End Cover with Return Spring	4	55
Solenoid (480V, 60 cycle) No Spring Return	1 & 4	57
Solenoid (480V, 60 cycle) Full Return Spring	1 & 2	58
Solenoid (480V, 60 cycle) with Centering Spring	1 & 5	59
Solenoid (125V DC) No Spring Return	1 & 4	63
Solenoid (125V DC) Full Spring Return	1 & 2	64
Solenoid (125V DC) with Centering Spring	1 & 5	65
Solenoid (150V DC) No Spring Return	1 & 4	66
Solenoid (150V DC) Full Spring Return	1 & 2	67
Solenoid (150V DC) with Centering Spring	1 & 5	68
Solenoid (24V DC) No Spring Return	1 & 4	69
Solenoid (24V DC) Full Return Spring	1 & 2	70
Solenoid (24V DC) with Centering Spring	1 & 5	71
Solenoid (12V DC) No Spring Return	1 & 4	72
Solenoid (12V DC) Full Return Spring	1 & 2	73
Solenoid (12V DC) with Centering Spring	1 & 5	74
Solenoid (90V DC) No Spring Return	1 & 4	75
Solenoid (90V DC) Full Return Spring	1 & 2	76
Solenoid (90V DC) with Centering Spring	1 & 5	77
Solenoid (40V DC) No Spring Return	1 & 4	78
Solenoid (40V DC) Full Return Spring	1 & 2	79
Solenoid (40V DC) with Centering Spring	1 & 5	80
Solenoid (6V DC) No Spring Return	1 & 4	81
Solenoid (6V DC) Full Return Spring	1 & 2	82
Solenoid (6V DC) with Centering Spring	1 & 5	83
Solenoid (12V DC Explosion Proof) No Spring Return	1 & 4	84
Solenoid (12V DC Explosion Proof) Full Spring Return	1 & 2	85
Solenoid (12V DC Explosion Proof) with Centering Spring	1 & 5	86
Button, Panel-Mounted, No Spring Return	-	87
Button, Panel-Mounted, Full Return Spring	2	88
Button, Panel-Mounted, with Centering Spring	3	89
Detent Kit, Two-Position	4	90
Detent Kit, Three-Position	4	91
Solenoid (120V, 60 cycle) No Spring Return (Explosion Proof)	1 & 4	92
Solenoid (120V, 60 cycle) Full Return Spring (Explosion Proof)	1 & 2	93
Solenoid (120V, 60 cycle) with Centering Spring (Explosion Proof)	1 & 5	94
Solenoid (240V, 60 cycle) No Spring Return (Explosion Proof)	1 & 4	95
Solenoid (240V, 60 cycle) Full Return Spring (Explosion Proof)	1 & 2	96
Solenoid (240V, 60 cycle) with Centering Spring (Explosion Proof)	1 & 5	97
End Cover Kit	-	98

Notes:

- Molded waterproof coils standard in all valves.
- Not normally used when valve is to have two operators. Use an operator with no spring return or one with centering spring. Installation on the "A" End of two- or three-way valve makes normally closed valve. Installation on the "B" End makes normally open valve.

- When used as only operator on valve, specify Centering Spring Kit (Code 54) for other end. When used with another operator, operator must be one with centering spring.
- To be used only on valve with another operator.
- To be used only with another operator having centering spring.
- Cannot be used with low pressure pilot operator on opposite end.
- For 1/4" valves only.

**“D” Pilotair® Valves
Basic Valve
Solenoid Operator Conversion Kits**

**BASIC VALVE
SOLENOID OPERATOR CONVERSION KITS**

To Convert Basic Valve Portion to a Piped Solenoid Operator; Select one of the following Part Numbers

VIEW	VALVE TYPE	¼" PART NO.	¼" MODEL NO.	½" PART NO.	½" MODEL NO.
A	Two-way and Three-way, Open Exhaust	R431009140	PD-020100-K0000	R431008385	PD-040100-K0000
E	Three-Way, Tapped Exhaust	R431009130	PD-020200-K0000	R431009235	PD-040200-K0000
B	Two-Way and Three-Way, Open Exhaust	R431009129	PD-020300-K0000	R431009236	PD-040300-K0000
F	Three-Way, Tapped Exhaust	R431009128	PD-020400-K0000	R431008401	PD-040400-K0000
C	Four-Way, Open Exhaust	R431009127	PD-020500-K0000	R431008407	PD-040500-K0000
D	Four-Way, Open Exhaust	R431009126	PD-020600-K0000	R431008421	PD-040600-K0000
G	Four-Way, Tapped Exhaust	R431009238	PD-020700-K0000	R431009237	PD-040700-K0000
H	Four-Way, Tapped Exhaust	R431009239	PD-020800-K0000	R431008438	PD-040800-K0000

Conversion Kits include tubing cut to length and formed required fittings, and special tapped body segment. Shaded areas indicate material furnished (when a different length is required, this tube is also in the kit.) Dotted lines indicate alternate piping arrangement, depending on the location of the solenoid operator.

Single Solenoid Valves

Double Solenoid Valves

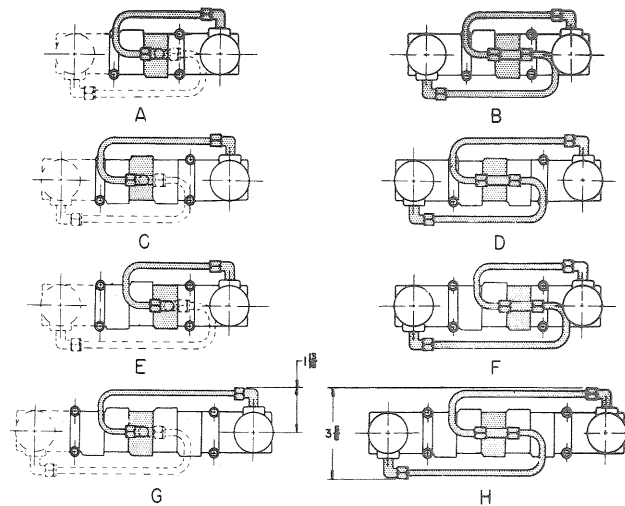

“D” Pilotair® Valves
Repair Kits

MINOR REPAIR KITS FOR “D” PILOTAIR VALVE PORTIONS

NEW KIT P/N	OLD KIT P/N	DESCRIPTION
		¼"
R431007355	P -068829-00000	Kit, Minor Repair F/PD2-20,31 Valve
R431007356	P -068830-00000	Kit, Minor Repair F/PD2-32,41,43,845 Valve
R431007357	P -068831-00000	Kit, Minor Repair F/PD2-42,44,846 Valve

NEW KIT P/N	OLD KIT P/N	DESCRIPTION
		½"
R431007363	P -068837-00000	Kit, Minor Repair F/PD4-20,31 Valve
R431007364	P -068838-00212	Kit, Minor Repair F/PD4-32,41,43, & 45 Valve
R431007365	P -068839-00215	Kit, Minor Repair F/PD4-42, 44, & 46 Valve

The above minor kits contain seal retainers, and a tube of grease for the indicated models.

MAJOR REPAIR KITS FOR “D” PILOTAIR VALVE PORTIONS

NEW KIT P/N	OLD KIT P/N	DESCRIPTION
		¼"
R431007349	P -068823-00000	Kit, Major Repair F/PD2-20 Valve
R431007350	P -068824-00000	Kit, Major Repair F/PD2-31 Valve
R431007351	P -068825-00000	Kit, Major Repair F/PD2-32 Valve
R431006513	P -064877-00000	Kit, Major Repair F/PD2-41 Valve
R431007352	P -068826-00000	Kit, Major Repair F/PD2-42 Valve
R431006514	P -064878-00000	Kit, Major Repair F/PD2-43 Valve
R431007353	P -068827-00000	Kit, Major Repair F/PD2-44 Valve
R431006515	P -064879-00000	Kit, Major Repair F/PD2-45 Valve
R431007354	P -068828-00000	Kit, Major Repair F/PD2-46 Valve

NEW KIT P/N	OLD KIT P/N	DESCRIPTION
		½"
R431007358	P -068832-00000	Kit, Major Repair F/ PD4-20 Valve
R431007319	P -068539-00000	Kit, Major Repair F/PD4-31 Valve
R431007359	P -068833-00000	Kit, Major Repair F/PD4-32 Valve
R431007320	P -068540-00000	Kit, Major Repair F/PD4-41 Valve
R431007360	P -068834-00000	Kit, Major Repair F/PD4-42 Valve
R431007321	P -068541-00000	Kit Major Repair F/PD4-43 Valve
R431007361	P -068835-00000	Kit, Major Repair F/PD4-44 Valve
R431007322	P -068542-00000	Kit, Major Repair F/PD4-45 Valve
R431007362	P -068836-00000	Kit, Major Repair F/PD4-46 Valve

The above major kits contain the minor repair kit plus a stainless steel spool.

With the above kits and parts, the elastomer seals and some common wear parts in the basic valve portion of the assemblies can be repaired. On severely worn or damaged valves, additional parts may be required.

The basic valve portion kits do not contain any parts for the mechanical operator portions of the valves. The mechanical operator portion of the valves should be repaired when necessary, with individually selected parts and tested before being put in service. Refer to Service Manual SM-700.7501 for additional part information and service instructions on the Type “D” PILOTAIR pneumatic directional valves.

OPTIONAL COILS

New Part No.	Old Part No.	Coil Voltage
R431005915	P -061920-00000	(120 Volts - 6- Hz)
R431005916	P -061920-00001	(240 Volts - 60 Hz)
R431005917	P -061920-00002	(480 Volts - 60 Hz)
R431005918	P -061920-00003	(24 Volts DC)
R431005919	P -061920-00004	(12 Volts DC)
R431009115	P -061920-00005	(90 Volts DC)
R431009107	P -061920-00007	(6 Volts DC)
R431009117	P -061920-00011	(12 Volts - 60 Hz)

REPAIR PARTS FOR SOLENOID OPERATORS

New Part No.	Old Part No.	Description
R431005645	P -060969-00000	Kit, Minor Solenoid Repair - PD2 - and PD4 - Valves (Includes Plunger, Spring Base Gasket)
R431002033	P -049708-00212	O-ring, Pilot Piston (Standard) - PD2 - Valves
R431002035	P -049708-00215	O-ring, Pilot Piston (Standard) - PD4 - Valves

NOTE: PISTON O-ring is also used in operator codes - 10, -11, -12, and all solenoid operators.

“D” Pilotair® Pneumatic Directional Control Valves Applications

TWO-WAY VALVE

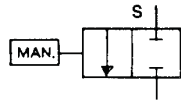

To control air flow in a line and not vent downstream pressure when the valve is closed. Segregating branches of a system is a typical application.

THREE-WAY VALVE - OPEN EXHAUST

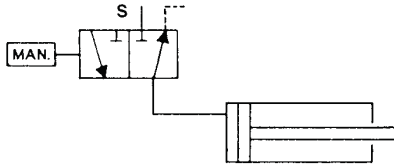

To control air flow in a line and to vent downstream pressure when the valve is closed. Operating a single-acting cylinder is a typical application.

THREE-WAY VALVE - TAPPED EXHAUST

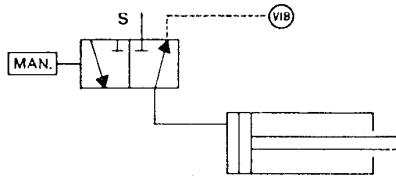

To control air flow in a line and to re-use air in the downstream line when the valve is closed. Using exhaust air to operate a vibrator or clean and eject work is a typical application.

THREE-WAY AND FOUR-WAY VALVES

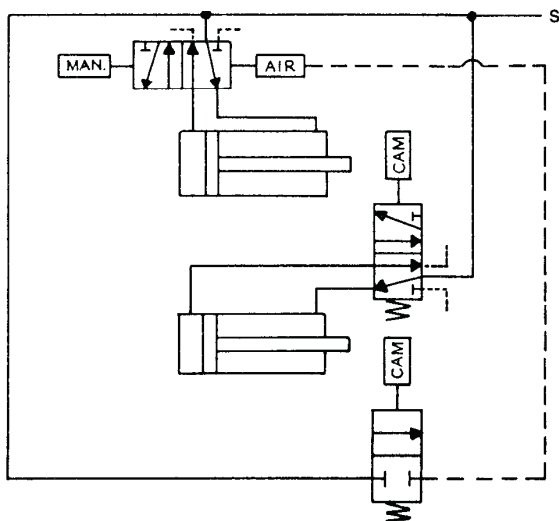

To ensure that one operation of a system is completed before the next operation begins.

FOUR-WAY VALVE - OPEN EXHAUST

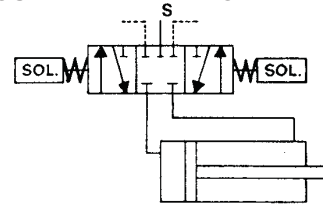

To control air flow from a common supply into one or the other of two lines allowing it to flow into one line while venting the other. Operation of double acting cylinder is a typical application.

FOUR-WAY VALVE - TAPPED EXHAUST

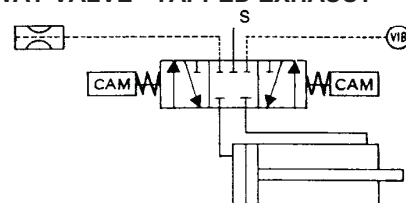

To control air flow from a common supply into one or the other of two lines. Allows air flow into one line while venting the exhaust air from the other into a separate line for reusing or remote venting.

THREE-WAY AND FOUR-WAY VALVE

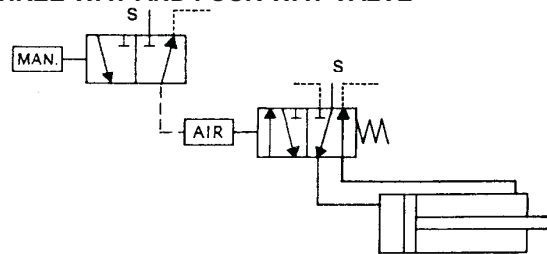

To operate a double-acting cylinder from a remote control station.

THREE-WAY VALVE - OPEN EXHAUST

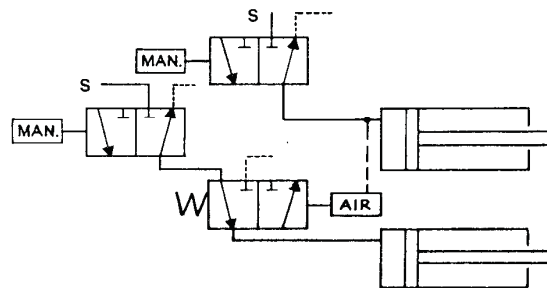

To prevent the operation of one branch of an air circuit while there is air pressure in another branch of the same system.

“D” Pilotair® Pneumatic Directional Control Valves

Model code (old part number) to current part number crossover

Model Code	Part No.	Model Code	Part No.	Model Code	Part No.	Model Code	Part No.
P-005014-00000	R431000479	P-049835-00077	R431002287	P-050861-00030	R434004510	P-063190-00000	R431006204
P-005014-00002	R431000480	P-049866-00015	R431002348	P-050861-00031	R431002790	P-064393-00000	R431006409
P-005042-00000	R431000482	P-049901-00044	R431002430	P-051363-00000	R431002905	P-064877-00000	R431006513
P-005042-00001	R431000483	P-049904-00071	R431002474	P-051364-00000	R431002906	P-064878-00000	R431006514
P-026346-00000	R431000600	P-049979-00000	R431002570	P-051500-00000	R431002910	P-064879-00000	R431006515
P-027240-00000	R431000773	P-049985-00001	R431002578	P-051635-00000	R431002933	P-065933-00000	R431006730
P-028996-00000	R431000925	P-049985-00003	R431002579	P-051636-00000	R431002934	P-065943-00000	R431006732
P-028996-00001	R431000926	P-049985-00005	R431002580	P-051677-00000	R431002936	P-066154-00000	R431009245
P-030275-00000	R431001046	P-049985-00007	R431002581	P-051732-00000	R431002943	P-066230-00000	R431006787
P-030304-00000	R431001051	P-049985-00009	R431002582	P-051838-00000	R431002944	P-066235-00000	R431006790
P-030305-00000	R431001052	P-049985-00011	R431002583	P-051925-00000	R431002954	P-066335-00000	R431006804
P-030844-00000	R434001336	P-049994-00001	R431002602	P-051958-00000	R431002955	P-066336-00000	R431006805
P-030868-00000	R434001341	P-049994-00003	R431002603	P-052028-00000	R431002957	P-066418-00000	R431006816
P-031245-00000	R434001853	P-050402-00000	R431002635	P-052033-00000	R431002961	P-066539-00000	R431006831
P-031488-00000	R434001844	P-050568-00000	R431002667	P-052046-00000	R431002966	P-066569-00000	R431006835
P-031659-00000	R434001934	P-050569-00000	R431002669	P-052075-00000	R431002968	P-066611-00001	R431006841
P-031772-00000	R434001918	P-050570-00000	R431002670	P-052079-00000	R431002969	P-066611-00002	R431006842
P-032002-00000	R431001277	P-050570-00001	R431002671	P-052081-00000	R431002970	P-066612-00000	R431006843
P-032060-00000	R431001282	P-050570-00002	R431002672	P-052124-00000	R431002972	P-066613-00000	R431006844
P-032108-00000	R434001744	P-050570-00003	R431002673	P-052617-00000	R431002986	P-066614-00000	R431006845
P-032149-00000	R434001747	P-050571-00000	R431002675	P-052901-00000	R431003036	P-066615-00000	R431006846
P-032150-00000	R434001735	P-050572-00000	R431002676	P-052928-00000	R431003037	P-066622-00001	R431006849
P-032488-00000	R431001356	P-050573-00000	R431002677	P-052995-00000	R431003072	P-066624-00000	R431006850
P-032625-00000	R431001375	P-050574-00000	R431002678	P-052996-00000	R431003073	P-066822-00000	R431006888
P-032627-00000	R431001377	P-050578-00000	R431002679	P-052996-00001	R431003074	P-066838-00000	R431006893
P-032628-00000	R431001378	P-050613-00000	R431002686	P-053001-00000	R431003080	P-066839-00000	R431006894
P-048122-00000	R431001515	P-050614-00000	R431002687	P-053071-00000	R431003095	P-066989-00000	R431006982
P-048246-00000	R431001565	P-050617-00000	R431002688	P-054592-00000	R431003390	P-066994-00000	R431006987
P-048402-00000	R431001612	P-050617-00002	R431002689	P-054592-00001	R431003391	P-067116-00000	R431007008
P-048402-00001	R431001613	P-050626-00000	R431002692	P-055448-00000	R431003735	P-067463-00000	R431007133
P-049247-00001	R431001731	P-050629-00000	R431002693	P-055517-00001	R431003796	P-067479-00000	R431007159
P-049528-00002	R431001845	P-050630-00002	R431002696	P-057566-00000	R431004178	P-067809-00001	R431007260
P-049578-00001	R431001867	P-050630-K0001	R431002700	P-057583-00001	R431004182	P-067896-00000	R431007262
P-049618-00002	R431001899	P-050633-00002	R431002702	P-057662-00002	R431004275	P-067897-00000	R431007263
P-049618-00003	R431001900	P-050719-00000	R431002731	P-058320-00000	R431004507	P-068539-00000	R431007319
P-049618-00004	R431001901	P-050721-00000	R431002732	P-058386-00000	R431004514	P-068540-00000	R431007320
P-049618-00005	R431001902	P-050722-00000	R431002733	P-059680-00000	R431005209	P-068541-00000	R431007321
P-049618-00009	R431001906	P-050723-00000	R431002734	P-059815-00000	R431005247	P-068542-00000	R431007322
P-049627-00000	R431001929	P-050724-00000	R431002735	P-060889-00000	R431005606	P-068818-00000	R431007347
P-049680-00004	R431001960	P-050726-00000	R431002737	P-060889-00004	R431005610	P-068823-00000	R431007349
P-049708-00215	R431002035	P-050727-00000	R431002739	P-060920-00000	R431005616	P-068824-00000	R431007350
P-049708-00218	R431002038	P-050728-00000	R431002740	P-061298-00001	R431005751	P-068825-00000	R431007351
P-049708-00232	R431002045	P-050729-00000	R431002741	P-061298-00002	R431005752	P-068826-00000	R431007352
P-049708-00233	R431002046	P-050731-00000	R431002742	P-061481-00000	R431005783	P-068827-00000	R431007353
P-049708-00334	R431002057	P-050734-00000	R431002744	P-061686-00000	R431005824	P-068828-00000	R431007354
P-049777-00000	R431002117	P-050736-00001	R431002748	P-061920-00000	R431005915	P-068829-00000	R431007355
P-049783-00212	R431002130	P-050736-00002	R431002749	P-061920-00001	R431005916	P-068830-00000	R431007356
P-049804-00002	R431002153	P-050740-00000	R431002750	P-061920-00002	R431005917	P-068831-00000	R431007357
P-049804-00006	R431002154	P-050860-00000	R431002776	P-061920-00003	R431005918	P-068832-00000	R431007358
P-049804-00008	R431002155	P-050861-00000	R431002779	P-061920-00004	R431005919	P-068833-00000	R431007359
P-049804-00014	R431002157	P-050861-00001	R431002780	P-061920-00028	R431005920	P-068834-00000	R431007360
P-049804-00084	R431002185	P-050861-00002	R431002781	P-062054-00000	R431005994	P-068835-00000	R431007361
P-049818-00004	R431002186	P-050861-00003	R431002782	P-062478-00000	R431006059	P-068836-00000	R431007362
P-049818-00005	R431002187	P-050861-00004	R431002783	P-062572-00000	R431006083	P-068837-00000	R431007363
P-049818-00018	R431002190	P-050861-00005	R431002784	P-062574-00000	R431006085	P-068838-00000	R431007364
P-049818-00019	R431002191	P-050861-00021	R431002787	P-062575-00000	R431006086	P-068839-00000	R431007365
P-049835-00005	R431002243	P-050861-00023	R431002788	P-062576-00000	R431006087	P-069096-00000	R431007406

“D” Pilotair® Pneumatic Directional Control Valves

Model code (old part number) to current part number crossover (cont.)

Model Code	Part No.	Model Code	Part No.	Model Code	Part No.	Model Code	Part No.
P-069290-00000	R431007438	PD-020031-00410	R431007807	PD-020032-09898	R431007893	PD-020045-05291	R431007991
P-069734-00000	R431007485	PD-020031-00490	R431009443	PD-020032-K0000	R431007894	PD-020045-K0000	R431007993
P-069738-K0000	R431007490	PD-020031-00500	R431007808	PD-020041-00011	R431009039	PD-020046-00191	R431007995
P-069753-00000	R431007499	PD-020031-00898	R431007810	PD-020041-00014	R431007898	PD-020046-00354	R431007996
P-069754-00000	R431007500	PD-020031-01010	R431007812	PD-020041-00100	R431007899	PD-020046-01212	R431007997
P-069756-00000	R431007501	PD-020031-01100	R431007813	PD-020041-00111	R431007900	PD-020046-03535	R431007998
P-069757-00000	R431007502	PD-020031-01110	R431007814	PD-020041-00191	R431007901	PD-020046-K0000	R431008001
P-069791-00000	R431007512	PD-020031-01187	R431007815	PD-020041-00198	R431007902	PD-020100-K0000	R431009140
P-069798-00000	R431007517	PD-020031-01198	R431007816	PD-020041-00312	R431007904	PD-020131-07001	R431008006
P-069804-00000	R431007518	PD-020031-01498	R431007820	PD-020041-00354	R431007905	PD-020131-07098	R431008007
P-069975-00000	R431007527	PD-020031-02098	R431007823	PD-020041-00898	R431007907	PD-020131-07301	R431008008
PD-020000-K0001	R431007748	PD-020031-02398	R431007825	PD-020041-01010	R431007908	PD-020131-K0000	R431008010
PD-020000-K0002	R431007749	PD-020031-05500	R434001062	PD-020041-01100	R431009257	PD-020200-K0000	R431009130
PD-020000-K0003	R431007750	PD-020031-05501	R431007827	PD-020041-01198	R431007910	PD-020300-K0000	R431009129
PD-020000-K0004	R431007751	PD-020031-07098	R431007829	PD-020041-01212	R431007911	PD-020400-K0000	R431009128
PD-020000-K0005	R431007752	PD-020031-07398	R431007830	PD-020041-01498	R431007914	PD-020500-K0000	R431009127
PD-020000-K0006	R431009217	PD-020031-08710	R431007832	PD-020041-01515	R431009040	PD-020541-00014	R431008018
PD-020000-K0008	R431007754	PD-020031-08790	R431007834	PD-020041-02098	R431007915	PD-020541-01400	R431008019
PD-020000-K0009	R431007755	PD-020031-08798	R431007835	PD-020041-05354	R431007919	PD-020541-07098	R431008020
PD-020000-K0010	R431007756	PD-020031-08898	R431007836	PD-020041-07098	R431007920	PD-020600-K0000	R431009126
PD-020000-K0011	R431007757	PD-020031-09087	R431007838	PD-020041-08898	R431007924	PD-020641-00000	R431008023
PD-020000-K0012	R431007758	PD-020031-09802	R431007839	PD-020041-K0000	R431007927	PD-020641-01313	R431009207
PD-020000-K0013	R431007759	PD-020031-09811	R431007840	PD-020042-00190	R431007931	PD-020643-07171	R431008029
PD-020000-K0014	R431007760	PD-020031-09814	R431007841	PD-020042-00191	R431007932	PD-020700-K0000	R431009238
PD-020000-K0015	R431007761	PD-020031-09820	R431007842	PD-020042-00354	R431007934	PD-020800-K0000	R431009239
PD-020000-K0018	R431009218	PD-020031-09870	R431007844	PD-020042-00898	R431007936	PD-040000-00078	R431008083
PD-020000-K0019	R431007762	PD-020031-09887	R431007846	PD-020042-01010	R431009357	PD-040000-K0001	R431008104
PD-020000-K0020	R431007763	PD-020031-K0000	R431007847	PD-020042-01198	R431007937	PD-040000-K0002	R431008105
PD-020000-K0021	R431007764	PD-020032-00002	R431007849	PD-020042-01313	R431007938	PD-040000-K0003	R431008106
PD-020000-K0022	R431009300	PD-020032-00011	R431007850	PD-020042-01515	R431007940	PD-040000-K0004	R431008107
PD-020000-K0023	R431007765	PD-020032-00020	R431007852	PD-020042-05298	R431007945	PD-040000-K0005	R431008108
PD-020000-K0038	R431008857	PD-020032-00191	R431007857	PD-020042-05354	R431007946	PD-040000-K0006	R431009219
PD-020000-K0052	R431007767	PD-020032-00198	R431007858	PD-020042-06969	R431007947	PD-040000-K0008	R431008109
PD-020000-K0053	R431007768	PD-020032-00354	R431007859	PD-020042-07171	R431007950	PD-040000-K0009	R431008110
PD-020000-K0054	R431007769	PD-020032-00410	R431007860	PD-020042-09292	R431007953	PD-040000-K0010	R431008111
PD-020000-K0055	R431007770	PD-020032-00598	R431007863	PD-020042-K0000	R431007955	PD-040000-K0011	R431008112
PD-020000-K0070	R431007774	PD-020032-01010	R431007867	PD-020043-00191	R431007957	PD-040000-K0012	R431008113
PD-020000-K0071	R431007775	PD-020032-01011	R431009038	PD-020043-00354	R431007960	PD-040000-K0013	R431008114
PD-020000-K0072	R431009035	PD-020032-01020	R434004531	PD-020043-01010	R431007961	PD-040000-K0014	R431008115
PD-020000-K0073	R431007776	PD-020032-01100	R431007868	PD-020043-01212	R431007963	PD-040000-K0015	R431008116
PD-020000-K0087	R431007778	PD-020032-01110	R431007869	PD-020043-01515	R431007964	PD-040000-K0018	R431008118
PD-020000-K0088	R431007779	PD-020032-01198	R431007870	PD-020043-05354	R431007965	PD-040000-K0019	R431008119
PD-020000-K0090	R431007780	PD-020032-01212	R431007871	PD-020043-05403	R431007966	PD-040000-K0020	R431008120
PD-020000-K0091	R431007781	PD-020032-01313	R431007873	PD-020043-07098	R431007967	PD-040000-K0021	R431008121
PD-020000-K0098	R431007782	PD-020032-01400	R431007874	PD-020043-07171	R431007968	PD-040000-K0023	R431008123
PD-020020-00011	R431007784	PD-020032-01498	R431007875	PD-020043-07474	R431007969	PD-040000-K0034	R431008124
PD-020020-01198	R431007789	PD-020032-01798	R431007876	PD-020043-K0000	R431007971	PD-040000-K0052	R431008125
PD-020020-01498	R431007791	PD-020032-02098	R431007878	PD-020044-00191	R431007973	PD-040000-K0053	R431008126
PD-020020-02098	R431009036	PD-020032-05354	R431007880	PD-020044-00315	R431009041	PD-040000-K0054	R431008127
PD-020020-07098	R434001002	PD-020032-07098	R431007883	PD-020044-00354	R431007974	PD-040000-K0055	R431008128
PD-020020-08898	R431009037	PD-020032-07398	R431007885	PD-020044-01212	R431007976	PD-040000-K0058	R431008129
PD-020020-09811	R431007795	PD-020032-08898	R431007887	PD-020044-01515	R431007977	PD-040000-K0070	R431008131
PD-020020-09888	R431007798	PD-020032-09398	R431009346	PD-020044-05354	R431007979	PD-040000-K0071	R431008132
PD-020020-K0000	R431007799	PD-020032-09811	R431007888	PD-020044-K0000	R431007983	PD-040000-K0072	R431008133
PD-020031-00011	R431007801	PD-020032-09814	R431007889	PD-020045-00191	R431007986	PD-040000-K0073	R431008134
PD-020031-00014	R431007802	PD-020032-09820	R431007890	PD-020045-01212	R431007989	PD-040000-K0087	R431008135
PD-020031-00298	R431007805	PD-020032-09823	R431007891	PD-020045-01515	R431007990	PD-040000-K0088	R431008136

“D” Pilotair® Pneumatic Directional Control Valves

Model code (old part number) to current part number crossover (cont.)

Model Code	Part No.	Model Code	Part No.	Model Code	Part No.	Model Code	Part No.
PD-040000-K0090	R431008137	PD-040032-00004	R431008218	PD-040041-02398	R431008289	PD-040044-01515	R431008365
PD-040000-K0091	R431008138	PD-040032-00111	R431008219	PD-040041-05354	R431008290	PD-040044-07171	R431008368
PD-040000-K0093	R431009042	PD-040032-00191	R431008220	PD-040041-06400	R431008293	PD-040044-09494	R431008369
PD-040000-K0098	R431008139	PD-040032-00198	R431008221	PD-040041-06969	R431009254	PD-040044-K0000	R431008370
PD-040020-00011	R431009464	PD-040032-00354	R431008223	PD-040041-07001	R431008294	PD-040045-00191	R431008372
PD-040020-00014	R431009043	PD-040032-00490	R431008225	PD-040041-07098	R431008295	PD-040045-01212	R431008374
PD-040020-00298	R431008145	PD-040032-00491	R434004865	PD-040041-07171	R431008296	PD-040045-02154	R431008376
PD-040020-00898	R431008148	PD-040032-00598	R431008226	PD-040041-07301	R431008297	PD-040045-05354	R431008377
PD-040020-01011	R431008150	PD-040032-00898	R431008227	PD-040041-07398	R431008298	PD-040045-K0000	R431008378
PD-040020-01100	R431008151	PD-040032-01010	R431008228	PD-040041-08790	R431008299	PD-040046-01010	R431009298
PD-040020-01198	R431008152	PD-040032-01100	R431008229	PD-040041-09494	R431008303	PD-040046-01212	R431008381
PD-040020-02098	R431009044	PD-040032-01198	R431008230	PD-040041-09820	R431009048	PD-040046-K0000	R431008383
PD-040020-07098	R431008159	PD-040032-01212	R431008231	PD-040041-09873	R431008305	PD-040100-K0000	R431008385
PD-040020-08790	R431008161	PD-040032-01313	R431008233	PD-040041-K0000	R431008306	PD-040120-01498	R431008387
PD-040020-08898	R431008163	PD-040032-01400	R431008234	PD-040042-00014	R431008308	PD-040131-01400	R431008389
PD-040020-09820	R431008166	PD-040032-01498	R431008235	PD-040042-00114	R431008310	PD-040131-01498	R431008390
PD-040020-K0000	R431008169	PD-040032-01515	R431009355	PD-040042-00173	R431008311	PD-040131-07098	R431008391
PD-040031-00001	R431009045	PD-040032-02098	R431008236	PD-040042-00190	R431008312	PD-040131-K0000	R431008392
PD-040031-00100	R431008172	PD-040032-02154	R431008858	PD-040042-00191	R431008313	PD-040200-K0000	R431009235
PD-040031-00110	R431008173	PD-040032-05290	R431008238	PD-040042-00198	R431008314	PD-040232-00000	R431008394
PD-040031-00113	R431008174	PD-040032-05354	R431008239	PD-040042-00254	R431008315	PD-040232-01798	R431008395
PD-040031-00190	R431008176	PD-040032-05501	R431008240	PD-040042-00315	R431008317	PD-040232-07301	R431008396
PD-040031-00198	R431008177	PD-040032-06401	R434004505	PD-040042-00321	R431009356	PD-040300-K0000	R431009236
PD-040031-00298	R431008178	PD-040032-07098	R431008242	PD-040042-00354	R431008318	PD-040400-K0000	R431008401
PD-040031-00490	R431008179	PD-040032-07398	R431008244	PD-040042-00410	R431008320	PD-040432-07171	R431008404
PD-040031-00598	R431008181	PD-040032-08501	R431009252	PD-040042-00490	R431008321	PD-040432-07474	R431008405
PD-040031-00898	R431008182	PD-040032-08898	R431008247	PD-040042-01010	R431008323	PD-040500-K0000	R431008407
PD-040031-01010	R431008183	PD-040032-09087	R431008248	PD-040042-01198	R431008324	PD-040541-00114	R431008409
PD-040031-01100	R431008184	PD-040032-09398	R431008249	PD-040042-01212	R431008325	PD-040541-00173	R431008410
PD-040031-01110	R431008185	PD-040032-09802	R431008250	PD-040042-01313	R431008326	PD-040541-01400	R431008411
PD-040031-01198	R431008186	PD-040032-09811	R431008251	PD-040042-01401	R431008327	PD-040541-01401	R431008412
PD-040031-01313	R431008187	PD-040032-K0000	R431008253	PD-040042-01498	R431008328	PD-040541-01498	R431008413
PD-040031-01400	R431008188	PD-040041-00001	R431008255	PD-040042-01515	R431008329	PD-040541-07098	R431008415
PD-040031-01401	R431008189	PD-040041-00014	R431008257	PD-040042-02098	R431008330	PD-040541-07301	R431008416
PD-040031-01404	R431008190	PD-040041-00098	R431008258	PD-040042-02154	R431009049	PD-040541-09873	R431008418
PD-040031-01498	R431008191	PD-040041-00110	R431008259	PD-040042-02398	R431008331	PD-040541-K0000	R431008419
PD-040031-01904	R431008194	PD-040041-00114	R431008260	PD-040042-05354	R431008334	PD-040600-K0000	R431008421
PD-040031-02098	R431008195	PD-040041-00155	R431008261	PD-040042-07098	R431008337	PD-040641-01313	R431008423
PD-040031-02398	R431008196	PD-040041-00173	R431008262	PD-040042-08790	R434004894	PD-040641-01515	R431008424
PD-040031-05501	R431009046	PD-040041-00190	R431008263	PD-040042-09802	R431008341	PD-040641-07171	R431008425
PD-040031-05804	R431008199	PD-040041-00191	R431008264	PD-040042-K0000	R431008343	PD-040641-07474	R431008426
PD-040031-07000	R431008201	PD-040041-00198	R431008265	PD-040043-00098	R434004863	PD-040643-07171	R431008428
PD-040031-07098	R431008202	PD-040041-00298	R431008266	PD-040043-00191	R431008346	PD-040643-09494	R431008429
PD-040031-07398	R431008203	PD-040041-00354	R431008269	PD-040043-00354	R431008347	PD-040700-K0000	R431009237
PD-040031-08790	R431008204	PD-040041-00374	R431008270	PD-040043-01010	R431008348	PD-040742-00114	R431008432
PD-040031-09001	R431008205	PD-040041-00490	R431008271	PD-040043-01100	R431009361	PD-040742-01401	R431008433
PD-040031-09004	R431009444	PD-040041-01010	R431008277	PD-040043-01212	R431008350	PD-040742-07098	R431008434
PD-040031-09087	R431008206	PD-040041-01100	R431008278	PD-040043-01515	R431008351	PD-040742-K0000	R431008436
PD-040031-09808	R431009367	PD-040041-01198	R431008279	PD-040043-02154	R431008352	PD-040800-K0000	R431008438
PD-040031-09811	R431008209	PD-040041-01212	R431008280	PD-040043-05354	R431008353	PD-040842-01515	R431008440
PD-040031-09814	R431008210	PD-040041-01313	R431008281	PD-040043-07171	R431008354	PD-040842-06969	R431008441
PD-040031-09820	R431008211	PD-040041-01400	R431008282	PD-040043-09494	R431008357	PD-070031-00111	R434004142
PD-040031-09870	R431008212	PD-040041-01401	R431008283	PD-040043-K0000	R431008358	PD-070032-00100	R434000882
PD-040031-09873	R431008213	PD-040041-01498	R431008284	PD-040044-00191	R431008361	PD-070032-00500	R434001131
PD-040031-09888	R434004839	PD-040041-01515	R431008285	PD-040044-00354	R431008363	PD-070043-01515	R434004942
PD-040031-09893	R434004585	PD-040041-02098	R431008287	PD-040044-01104	R434004928	PD-070232-06498	R434000885
PD-040031-K0000	R431008215	PD-040041-02154	R431009047	PD-040044-01212	R431008364		

“P” Rotair® Valves

Multiple Handle Position Three-Way Valve Combinations

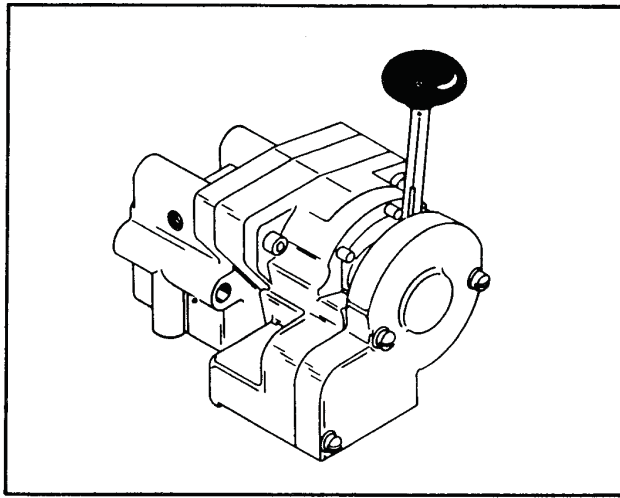

The ROTAIR Valve is a handle-operated, rotary-type, directional control valve. Air-flow patterns are selected by using up to eight distinct handle positions, and delivery air is directed through a rotary valve to the necessary number of delivery ports.

Those models with an “S” suffix (see the “Identity Schedule”) have a limit-switch which is activated in the NEUTRAL position. This electrical switch can provide a neutral starting interlock when the starting switch to the engine starting relay is wired through it.

The number of handle positions in each valve is indicated by the initial digit in the model designation (see the “Identity Schedule”).

Some models of the Rotair Valve are equipped with a “Downshift Inhibitor” (See the Identity Schedule). This safety feature prevents downshifting until the proper electrical signal is obtained from the transmission. Detented models have pins in the cover only, except between neutral & 1st.

INSTALLATION

The Rotair Valve can be installed in any position convenient for manual operation; however, an installation with the handle vertical is recommended. As assembled, each valve includes a pipe bracket, or subbase, to which all piping connections are made. Pipe connections are clearly marked by numbers on the bracket. All ports between the pipe bracket and valve assembly are sealed with tetraseals*. This arrangement permits easy removal of the valve assembly without disturbing the pipe connections.

An adequate air filter should be installed in the supply line ahead of the ROTAIR Valve. Clean air is essential to the trouble-free life of the rotary valve seat.

When the neutral start interlock is desired, the terminals marked “normally closed” and “common”, on the limit switch, should be used. The “normally open” terminal can be used for other purposes since the circuit will be made at all times other than in neutral.

OPERATION

(reference assembly views on page 54)

Maximum operating pressure for the ROTAIR Valve is 150 psi (10.3 bar), with a temperature range of -40°F to +160°F (-40°C to 71°C). The handle-positioning labyrinth is composed of two mating parts, the body (1), and cover (2). The handle shaft (3) moves, by side-to-side motion, through an arc of designated handle positions, assuring correct sequence of operation. A handle position cannot be bypassed unintentionally on those models with a labyrinth slot pattern.

Movement of the handle rotates the rotary valve (4), acting through the rotary valve key (5). The ported rotary valve is aligned with ports in the rotary valve seat (6) as determined by handle position. The aligned ports form a passage for air to flow from the IN port to the numbered OUT ports. Those OUT ports which are not aligned to supply in particular handle position are connected to exhaust.

With the handle in NEUTRAL position on those models containing a limit-switch, the handle shaft, acting on the set screw (7), positions the switch lever (8) to activate the limit-switch (9).

The solenoid portion of the inhibitor (10) is wired to the electric switch on the transmission. The inhibitor is activated by presence of current during improper conditions for shifting. The inhibitor clutches (11 & 12) engage to prevent handle movement in the downshift direction, which if done at the wrong time, could cause damage to the engine and the transmission.

ADJUSTMENT

A set screw (7) is provided to adjust the trip point of the limit-switch, if necessary. This adjustment may be made externally through a hole in the bottom of the valve body. An additional function of the hole is drainage of water or sludge.

“P” Rotair® Valves Features and Identity Schedule

P Rotair valves offer dependability and long, trouble-free service. Corrosion resistance throughout the valve is ensured by the materials used.

The valve cover (2), pipe bracket (13), and the body (1) are die-cast aluminum. Handle-guide pins in the body are hardened steel, nickel-zinc plated. To eliminate maintenance problems and the need for frequent re-lapping of the rotary valve seat and rotary valve, caused by dirt and foreign matter in the air system, seven molded nylon, 150-micron strainers (14) are installed in the pipe bracket, one in each port. The pipe bracket was re-designed to accommodate these seven strainers, the single strainer in the IN port no longer being required.

A ni-resist iron rotary valve seat (6) is used, and seven tetraseals (11) now seal the pipe bracket and seat in the place of six larger “O” rings and one small “O” ring in the older design. Although not recommended, the new seat may be used with the old pipe bracket, but only when tetraseals replace

the six large “O” rings. The old seat cannot be used with the new pipe bracket because of the slight shift in port location to accommodate the new strainers.

Longer wear results from separate, hardened steel, nickel-zinc plated switch tips (15) attached to a single handle shaft (3), to activate the limit-switch in the selected handle position. Any of the shafts may be replaced by the current shaft as long as the appropriate switch tip is used. Made from tougher, more wear-resistant steel, also nickel-zinc plated, the current shaft is designed with rounded corners for smoother operation. In addition, the pin with cotter has been replaced with a nut and handle pin.

The rotary valve key has been redesigned to contain a handle leveler and spring, which replace the spring, shim, and spring seat formerly assembled inside the valve cover on the opposite side of the handle shaft.

OPTION: Latch for P”Rotair Part No. P -026578-00000

VALVE MODEL IDENTITY SCHEDULE

Valve Model	New Part No.	Old Part No.	Handle Position Designations	Type of Handle Movement	Special Details
5P-5S	R431003921	P -055804-00001	R/N /F1/F2/F3	Labyrinth	R2 & F4 positions blocked
6P-5S	R431003982	P -057081-00001	R1/N/F1/F2/F3/F4	Labyrinth	R2 position blocked
6P-2S	R431006031	P -062255-00000	R1/N/F1/F2/F3/F4	Labyrinth	12VDC Inhibitor, R2 pos. blocked
6P-1S	R431006324	P -063984-00001	R/N/1/2/2-4/2-5	Detented	Two forward position blocked
6P-5S	R431006581	P -065235-00001	N/1/2/3/4/5	Labyrinth	R position blocked
7P-5S	R431003722	P -055421-00001	R2/R1/N/F1/F2/F3/F4	Labyrinth	
7P-2S	Obsolete	P -060984-00001	R2/R1/N/F1/F2/F3/F4	Labyrinth	24VDC Inhibitor
7P-5	R431006216	P -063348-00000	R/N/1/2/3/4/5	Labyrinth	No neutral switch
7P-5S	R431005698	P -061184-00000	R3/R2/R1/N/F1/F2/F3	Labyrinth	F4 position blocked
7P-5S	R431003701	P -055380-00001	R/N/1/2/3/4/5	Labyrinth	
7P-7S	R431004176	P -057564-00001	R2/R1/N/F1/F2/F3/F4	Labyrinth	
7P-8S	R431004018	P -057250-00004	R3/R2/R1/N/F1/F2/F3	Labyrinth	Nameplate reversed
7P-8S	R431004019	P -057250-00006	F3/F2/F1/N/R1/R2/R3	Detented	Offset handle with “Z” slot
7P-9	Obsolete	P -058914-00001	R/N/1/2/3/4/5	Labyrinth	No neutral switch
7P-9S	R431006326	P -063985-00000	R/N/1/2/2-3/2-4/2-5	Detented	
7P-9S	R431006327	P -063985-00001	R/N/1/1-2/1-3/1-4/1-5	Detented	
7P-9S	R431006328	P -063985-00002	R/N/1/2/3/4/5	Detented	
7P-9S	R431006329	P -063985-00003	R/N/1/2/3/4/5	Detented	Switch trip at position 1
8P-1S	R431003806	P -055556-00003	R/N/F1/F2/F3/F4/F5/F6	Labyrinth	
8P-1S	R431003807	P -055556-00004	R/N/F1/F2/F3/F4/F5/F6	Labyrinth	
8P-2S	R431005595	P -060867-00004	R/N/F1/F2/F3/F4/F5/F6	Labyrinth	12VDC Inhibitor
8P-2S	R431005596	P -060867-00005	R/N/F1/F2/F3/F4/F5/F6	Labyrinth	24VDC Inhibitor
8P-1S	R431009150	P -064733-00000	R/N/F1/F2/F3/F4/F5/F6	Labyrinth	
8P-1S	R431006323	P -063983-00001	R/N/F1/F2/F3/F4/F5/F6	Labyrinth	24VDC Inhibitor

“P” Rotair® Valves

ASSEMBLY VIEWS

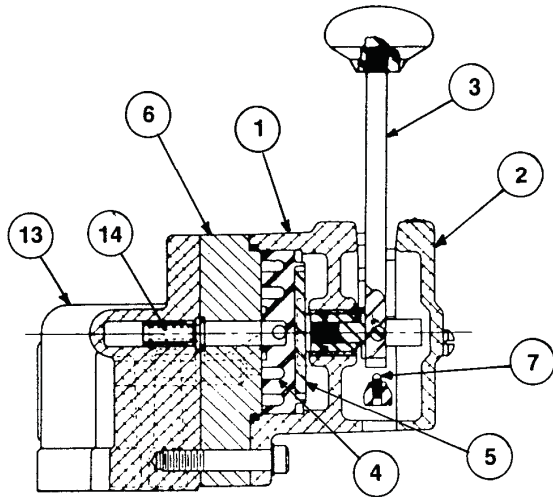

All models except those with detents or inhibitors.

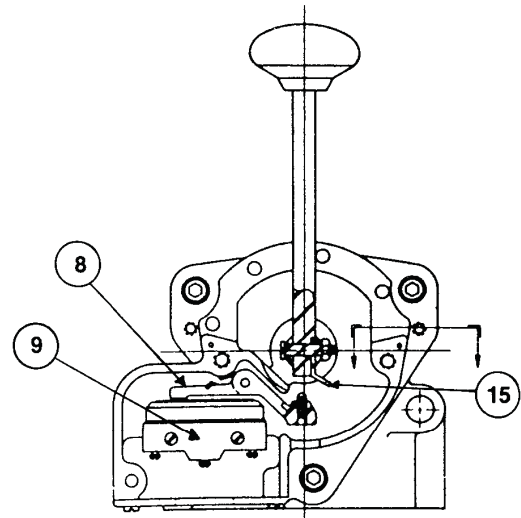
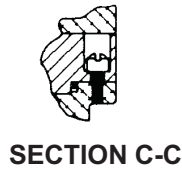

Typical operator portion all models.

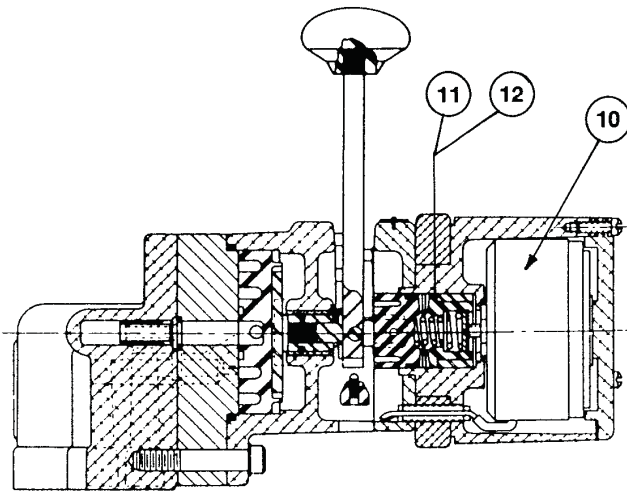

All Inhibitor Models

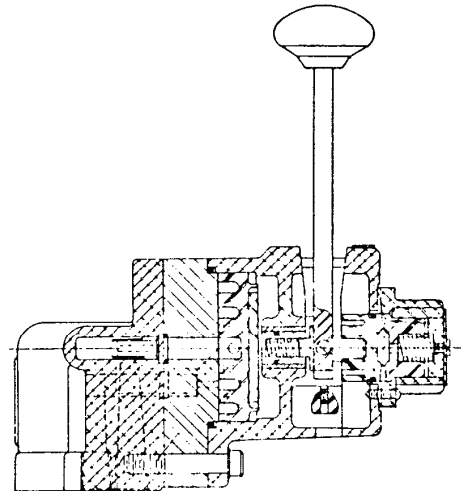

Detent Models

REPAIRING THE “P” ROTAIR VALVE

The rotary valve (polyacetal) and the rotary valve seat (nichrome cast iron) in these assemblies have their mating sealing surfaces machine lapped for sealing. When in need of repair, it is recommended that the valve be shop repaired with new parts as necessary. The valve portion can be removed from the pipe bracket without removing the piping connections. Refer to service manual SM-700.7600 for parts information and service instructions.

“P” ROTAIR® VALVES

HANDLE POSITION PORTING DIAGRAMS
(Listed counterclockwise when facing handle end of valve)

PART NO. R431003921, 5P-5S

HDL. POS.	PRESSURE SUPPLIED TO PORTS				
	1	2	3	4	5
R	X	X		X	
N	X	X			
F1	X	X	X		X
F2	X	X			X
F3	X				X

Port 6 in the “IN” Port.

PART NO. P -061325-00000, 6P-2S
R481006081, 6P-2S
R431003982, 6P-5S

HDL. POS.	PRESSURE SUPPLIED TO PORTS				
	1	2	3	4	5
R1	X	X		X	
N	X	X			
F1	X	X	X		X
F2	X	X			X
F3	X				X
F4					X

Port 6 is the “IN” Port.

PART NO. R431006325, 6P-1S

HDL. POS.	PRESSURE SUPPLIED TO PORTS			
	6	3	2	4
R			X	
N				
1	X			X
2		X		X
2-4		X		
2-5	X			

Port inside of the pipe bracket is “IN” Port. Ports #1 & 5 are plugged 1/8" exhaust port in the bracket.

PART NO. R431005698, 7P-5S

HDL. POS.	PRESSURE SUPPLIED TO PORTS				
	1	2	3	5	6
R3		X			
R2	X	X			
R1	X	X			X
N	X	X	X		X
F1	X		X	X	X
F2	X			X	X
F3	X			X	

Port 4 is in “IN” Port.

PART NO. R431003722 7P-5S
P -60984-00000, 7P-2S

HDL. POS.	PRESSURE SUPPLIED TO PORTS				
	1	2	3	4	5
R2		X	X	X	
R1	X	X		X	
N	X	X			
F1	X	X	X		X
F2	X	X			X
F3	X				X
F4					X

Port 4 is the “IN” Port.

PART NO. R4310056216, 7P-5

HDL. POS.	PRESSURE SUPPLIED TO PORTS					
	1	2	3	5	6	
R		X				
N	X	X				
1	X	X				X
2	X	X	X			X
3	X		X	X	X	
4	X			X	X	
5	X			X		

Port 4 is in “IN” Port.

PART NO. R431003701 7P-5S

HDL. POS.	PRESSURE SUPPLIED TO PORTS					
	1	3	4	5	6	
R	X					X
N	X			X	X	
1	X		X	X	X	
2		X	X	X	X	
3		X	X	X		
4		X		X		
5		X				

Port 2 is in “IN” Port.

PART NO. R431004019 7P-8S

HDL POS	PRESSURE SUPPLIED TO PORTS				
	1	2	3	4	5
R3				X	X
R2		X		X	X
R1		X	X		X
N			X		
F1	X	X	X		
F2	X	X		X	
F3	X			X	

Port 6 is the “IN” Port.

PART NO. R431004176 7P-7S

HDL. POS.	PRESSURE SUPPLIED TO PORTS				
	1	2	3	4	5
R2			X	X	X
R1				X	X
N				X	
F1		X		X	
F2		X	X	X	
F3	X	X	X		
F4	X	X			

Port 6 is the “IN” Port.

PART NO. R431009234 7P-9

HDL POS	PRESSURE SUPPLIED TO PORTS					
	1	2	3	4	5	6
5	X	X	X	X		X
4	X	X	X	X	X	
3	X	X	X		X	X
2	X	X	X	X	X	X
1	X	X	X	X	X	X
N	X	X	X	X	X	X
R	X	X		X	X	X

“IN” port located on pipe bracket

PART NO. R431006326, 7P-9S
R431006327, 7P-9S
R431006328, 7P-9S
R431006329, 7P-9S

HDL. POS.	PRESSURE SUPPLIED TO PORTS			
	6	3	2	5
R			X	
N				
1				X
2	X			X
2-3	X	X		X
2-4		X		
2-5	X			

Port in side of the pipe bracket is “IN” port. Port #4 is exhaust. #1 is plugged. See identity schedule for other handle positions designations.

PART NO. R431003806 8P-1S
R431003807, 8P-1S
R431005595, 8P-2S
R431005596, 8P-2S

HDL. POS.	PRESSURE SUPPLIED TO PORTS				
	1	2	3	5	6
R		X			
N	X	X			
F1	X				X
F2	X		X		X
F3	X		X	X	X
F4	X			X	X
F5	X			X	
F6				X	

Port 4 is the “IN” Port.

PART NO. R431009150, 8P-1S
R431006323, 8P-1S

HDL. POS.	PRESSURE SUPPLIED TO PORTS					
	1	6	3	2	5	4
R				X		
N						
F1		X				X
F2	X		X			X
F3	X		X		X	
F4	X	X			X	
F5	X				X	
F6					X	

“IN” port in the side of pipe bracket 1/8" Exhaust port is in the bracket

PART NO. R431006581, 6P-5S

HDL. POS.	PRESSURE SUPPLIED TO PORTS			
	6	3	2	5
N				
1				X
2	X			X
3	X	X		X
4		X		
5	X			

Port in side of the pipe bracket is “IN” port. Port #4 is exhaust. #1 is plugged.

PART NO. R431004019, 7P-8S

HDL. POS.	PRESSURE SUPPLIED TO PORTS				
	1	2	3	4	5
F3				X	X
F2		X		X	X
F1		X	X		X
N			X		
R1	X	X	X		
R2	X	X		X	
R3	X			X	

Port 6 is the “IN” port. 1/8" exhaust port is in the side of the pipe bracket.

NOTE:
“X” denotes port is pressurized in that position. Empty block indicates port is exhausted in that position.

“P” ROTAIR® VALVES
Outline Dimensions

OUTLINE DIMENSIONS
Models except those equipped with inhibitors or detents

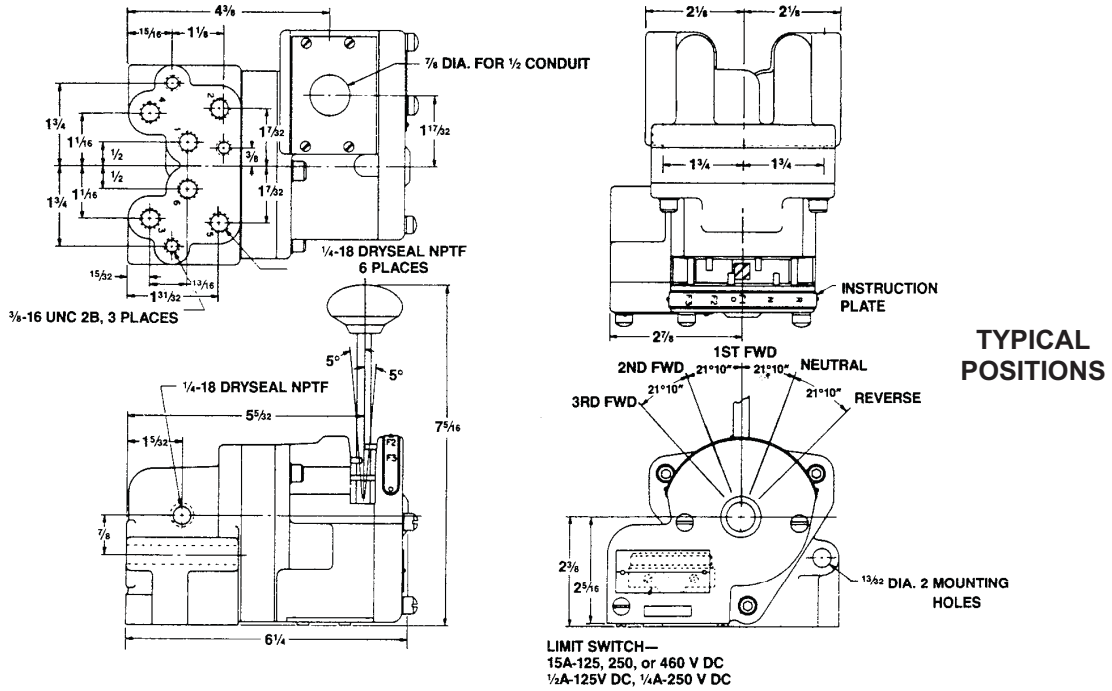

INHIBITOR MODELS

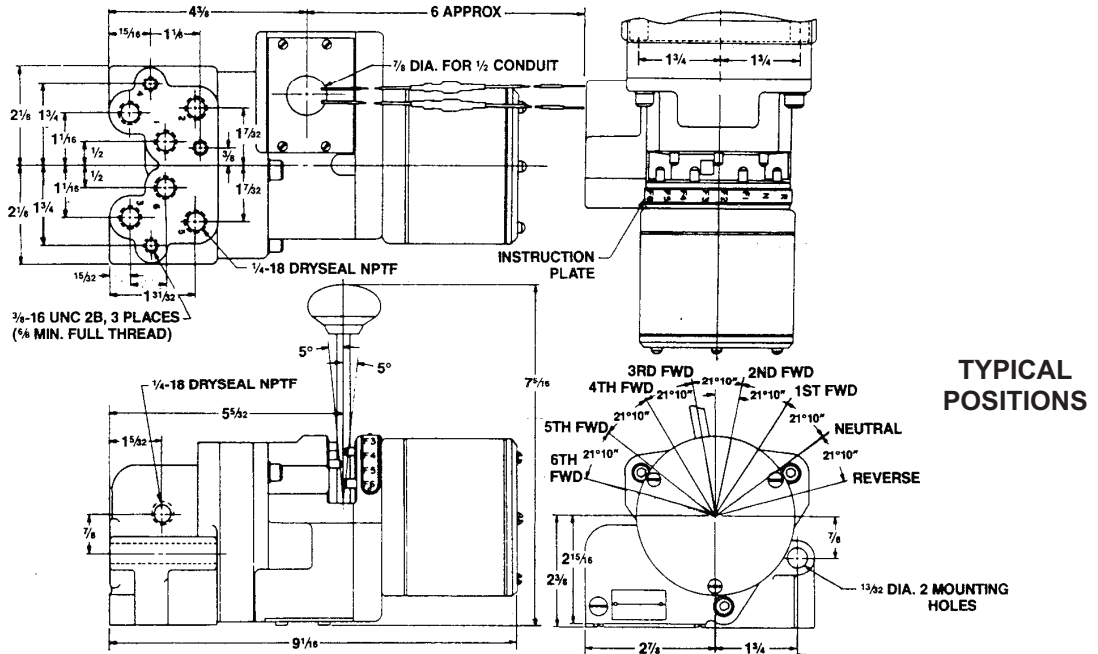

“P” ROTAIR[®] VALVES
Outline Dimensions
Models With Detents

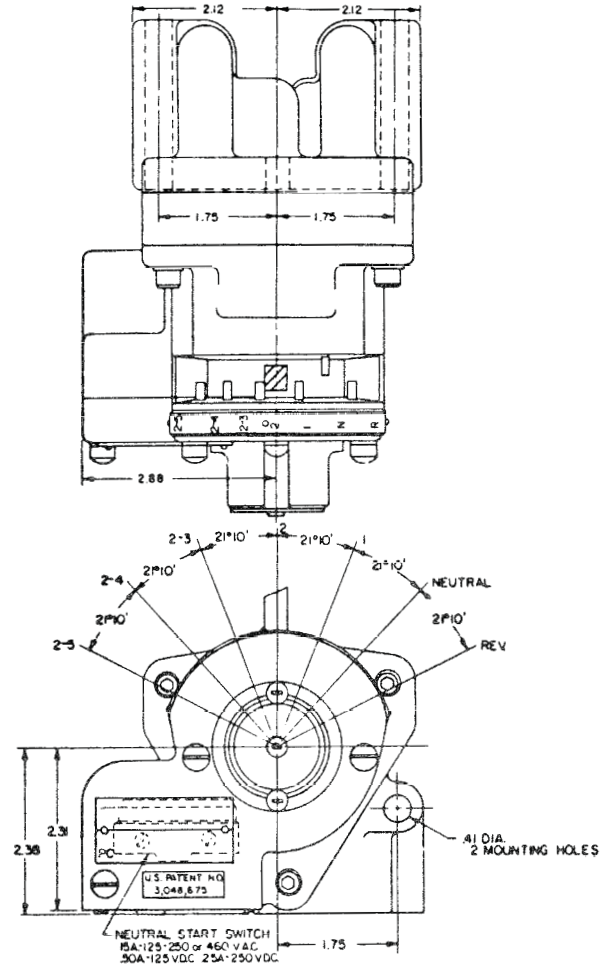
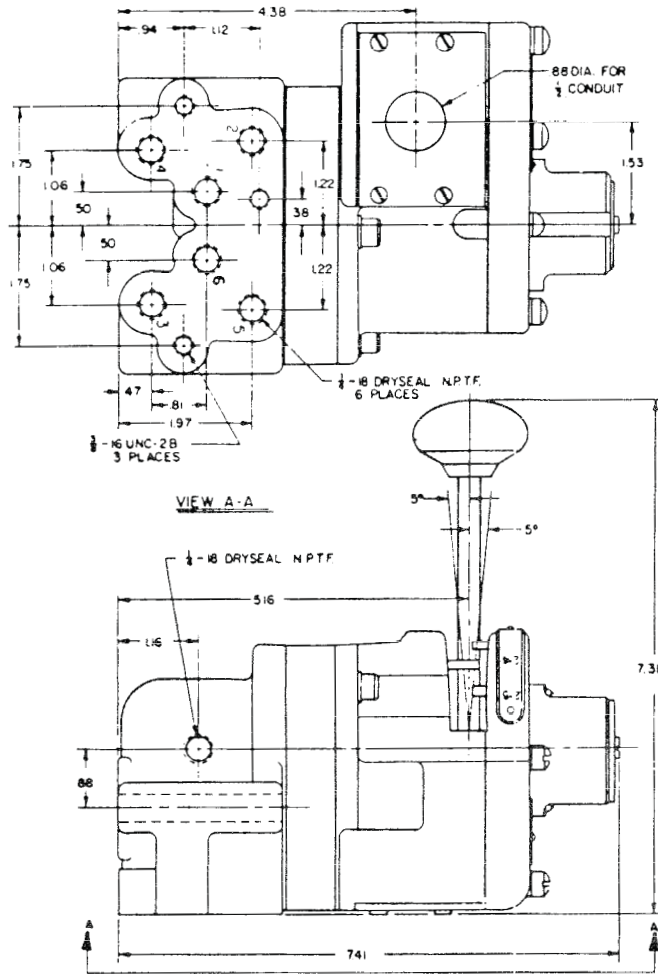

“P” ROTAIR® VALVES
Repair Kits

Repair Kit Part No.	Old Repair Kit Part No.	Description
R431004809	P -058906-K0000	Minor Repair All 7-P Rotair Valves
R431004806	P -058906-00001	Minor Repair - Spring Centered Handle Valves
R431004807	P -058906-00002	Minor Repair - Valves with Inhibitor
R431004808	P -058906-00003	Minor Repair - Valves with Detent Mechanism
R431004810	P -058907-00001	Major Repair for Valves (P -057250-00002), (P -057250-00005), R431004019 (P -057250-00004) & R431004020 (P -057250-00006)
R431005799	P -061608-00000	Rotary Valve for R431003806 & R431003807 (P -55556-3 & -4) and (P -60867-2, -3) & R431005595 (P -060867-00004) (lapped)
R431005801	P -061609-00000	Rotary Valve seat for R431003806 & R431003807 (P -055556-3 & -4) and (P -060867-2, -3) & R431005595 (P -060867-00004) lapped
R431006384	P -064210-00000	Seat for R431006326 (P -063985) & R431006581 (P -065325-00001)
R431006385	P -064212-00000	Rotary valve for R431006326 (P -063985) & R431006581 (P -065325-00001)

Repairing the “P” ROTAIR Valve

The rotary valve (polyacetal) and the rotary valve seat (nichrome cast iron) in the P Rotair have their mating sealing surfaces machine lapped for sealing. When in need of repair, it is recommended that the valve be shop repaired with new parts as necessary. The valve portion can be removed from the pipe bracket without removing the piping connections. Refer to service manual SM-700.7600 for parts information and service instructions (download from www.aventics.com/us).

Table of Contents for Section II (SC-800) Special Purpose Pneumatic Pressure Control Valves

	Page No.
TYPE "H" CONTROLAIR® VALVES	
FEATURE & SPECIFICATIONS	2-4
H-1 Models	4-5
H-2 Models	6-7
H-2-E Models	8-9
HC-2 Models	10
HD-2 Models	11
HE-2 Models	12
H-3 Models	13
H-4 Models	14
Repair Kit List	15
FLEXAIR® VALVES	
FEATURES & SPECIFICATIONS	16-18
How To Order	19
Dimensions	20-21
Repair Kit List	22
Part Number Index	23-29
TYPE "M" PLUS™ PRESSURE CONTROL VALVES	
FEATURES & SPECIFICATIONS	30-31
Repair Kit List	31
M-1 Models	32
M-2 Models	33
M-5 Models	34
MC-2 Models	35
ME-2 Models	36
Cross Reference/Identity Schedule	37
MOBILE/OILFIELD ACTUATORS AND CYLINDERS OVERVIEW	38

“H” Controlair® Valves Features and Specifications

The Type “H” CONTROLAIR Valves are a family of pneumatic pressure regulating, directional valves. They are versatile three- and four-way pressure regulating valves or a combination of pressure regulating and non-regulating three-way valves. Hand, foot or mechanically operated, these valves control both pressure and flow of air. Some control these functions in one air circuit. Others selectively control these functions in two separate and independent air circuits or in branches of the same circuit. Still others control these functions either selectively or simultaneously in three separate and independent branches of an air circuit.

With each valve, the position of the operator - lever, pedal, cam or knob - determines the air pressure delivered by the valve. Changing operator positions changes delivery pressure. Once the operator's position is set, a CONTROLAIR Valve maintains the delivery pressure for that position - automatically. It feeds more air into a circuit to compensate for leakage and operations which reduce pressure. It vents air from a circuit to compensate for operations and other conditions which would increase a circuit's pressure.

APPLICATIONS

Applications for “H” CONTROLAIR® Valves are limitless.

They operate:

Throttles	Rolling Mills	Marine Propulsion Engines
Clutches	Presses	Construction Equipment
Brakes	Shears	Oil Drilling Rigs
Clamps	Conveyors	Production Tools
Gates	Dredges	Cranes, Hoists & Draglines

and many other kinds of equipment and machines. In fact “H” CONTROLAIR Valves are used wherever it is necessary, or preferable, to have instant and convenient control of the flow of air into a pneumatic circuit and of the pressure build-up of air in that circuit.

FEATURES

Besides exceptional versatility, other CONTROLAIR Valve features are:

EASE OF OPERATION - as “H” CONTROLAIR Valves need only light operating forces, these valves increase both the efficiency and the output of operating personnel by decreasing operator fatigue and concentration required.

SENSITIVITY - the outlet pressure of “H” CONTROLAIR Valves having 60 lb. (27 Kg) graduating springs can be changed in increments of approximately 1/4 psi (0.02 bar). The outlet pressure of valves having 100 lb. (45 Kg) graduating springs can be changed in increments of approximately 1/2 psi (0.3 bar), other cataloged pressures are changed proportionately. After setting, “H” CONTROLAIR Valves maintain their outlet pressure within a range of approximately 1-1/2 psi (0.10 bar).

EASE OF MAINTENANCE - all pipe connections are made to a pipe bracket from which the CONTROLAIR Valve can be removed without disturbing the circuit's piping.

CORROSION RESISTANCE - diaphragms and seals

are made of oil-resistant synthetic rubber. All steel parts are plated. All other parts are made of anodized aluminum or bronze.

SIMPLICITY - CONTROLAIR Valves contain only a few wearing parts and these are easily replaced.

PARTS INTERCHANGEABILITY - all similar parts in the various types of CONTROLAIR Valves are interchangeable.

RUGGED, RELIABLE AND PRECISION BUILT.

TEMPERATURE RANGE -
-40°F to 160°F (-40°C to 71°C)

MAXIMUM SUPPLY PRESSURE -
200 psi (13.8 bar)

OUTLET PRESSURE -
According to model selected.

“H” Controlair® Valves

MODELS

“H” CONTROLAIR Valves are built in the following models:

H-1 - FOOT PEDAL operated for one pressure regulated circuit.

H-2 - HAND LEVER operated for one pressure regulated circuit

HC-2 - HAND LEVER operated for two pressure regulated circuits.

HD-2 - HAND LEVER operated for one pressure regulated circuit and two non-regulated circuits.

HE-2 - HAND LEVER operated for one pressure regulated circuit and one non-regulated circuit.

H-3 - CAM operated for one pressure regulated circuit.

H-4 - HAND KNOB operated for one pressure regulated circuit.

The H-2, HC-2, HD-2 and HE-2 CONTROLAIR Valves are available with any one of the following types of lever return or holding characteristics. These characteristics are indicated by the suffix added to the designation.

X - Self returning. The lever return from the extreme position to the valve’s “Neutral” or “Off” position when the operating force is removed.

LX - Self returning with latch. The lever returns to the valve’s “Neutral” or “Off” position when manually moved out of the latch position (extreme travel position).

FX - Self holding. The lever stays in any position in which it is placed. The holding friction is adjustable.

In addition to these models, other CONTROLAIR Valves are available which are not cataloged because they have modifications that limit their application.

OPERATION

The sensitive, precise pressure control of the “H” CONTROLAIR Valve and its ability to change delivery pressure in small increments are obtained through the use of a large responsive diaphragm. The ease with which an “H” CONTROLAIR Valve is operated is obtained by creating a differential between the counter-balanced air pressure and spring forces within the valve and by using this differential to open or to close valves.

When the CONTROLAIR Valve is in decreasing

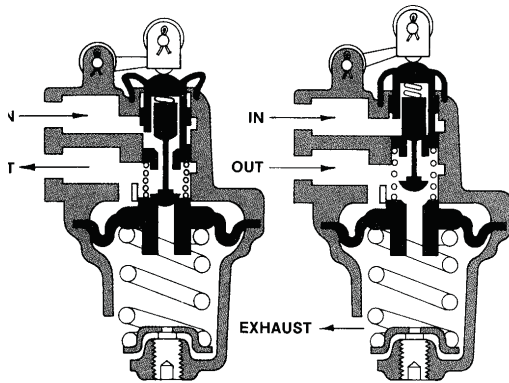

INCREASING PRESSURE DECREASING PRESSURE

pressure position, the inlet valve is closed and the exhaust valve is open to vent the OUT pressure to atmosphere, inlet pressure is on top of the closed inlet valve.

Should leakage or a temperature variation occur that would change the outlet pressure called for by the CONTROLAIR Valve’s operator position, this deviation in pressure opens either the CONTROLAIR Valve’s supply valve or its exhaust valve to restore the correct pressure.

In addition to having a pressure graduating valve, the HC-2, HD-2 and HE-2 CONTROLAIR Valves have one or two normally closed, non-graduating, three-way valves. When the lever of one of these CONTROLAIR Valves is moved 10° or more from its “Neutral” position, it opens one of the 3-way valves and holds it open. The

exhaust valves in these three-way valves are closed by initial movement from “Neutral” of the CONTROLAIR Valve lever. Further movement of the lever operates the pressure regulating portion.

A complete description of the operation for each CONTROLAIR Valve is in the Service Information publication for that valve.

Starting from decreasing pressure position, to increase the OUT pressure of an “H” CONTROLAIR Valve, its operator moves the valve assembly in contact with the exhaust valve seat. Initial movement of the valve assembly closes the passage from the CONTROLAIR Valve’s OUT line to atmosphere. Further movement of the assembly opens the passage between the CONTROLAIR Valve’s IN and OUT lines allowing inlet air to flow into the OUT line and to the upper face of the diaphragm.

As the flow of inlet air into the line raises the air pressure in the OUT line, it also increases the air pressure on top of the diaphragm. This pressure compresses the spring beneath the diaphragm and forces the diaphragm downward.

When the outlet pressure reaches the value called for by the amount of operator movement, the air pressure acting on the diaphragm has moved it enough to let the inlet valve spring close the inlet valve and stop further increase in pressure.

Further movement of the CONTROLAIR Valve operator to increase pressure moves the valve assembly and again opens the inlet valve. This allows additional air to flow into the OUT line until air pressure acting on the diaphragm depresses it enough to allow inlet valve to close.

Movement of the CONTROLAIR Valve operator to decrease outlet pressure decreases the force on the valve assembly and lets the spring beneath the valve assembly move it upward. This action lifts the exhaust valve from its seat and allows air in the OUT line to vent to atmosphere, thus decreasing air pressure in that line.

“H” Controlair® Valves

With less air pressure on top of the diaphragm, the spring beneath it raises the diaphragm, with its exhaust valve seat, toward the exhaust valve until it closes and stops the venting of air from the OUT line.

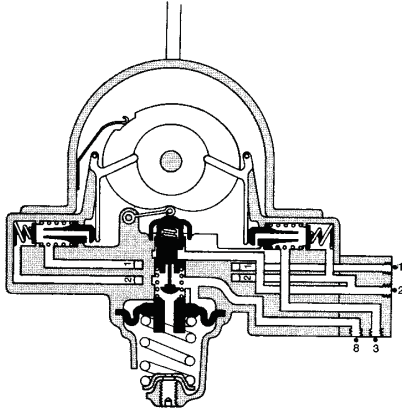

“HD” TYPE CONTROLAIR VALVE WITH NON-GRADUATING, THREE-WAY VALVES

H-1 CONTROLAIR® VALVE

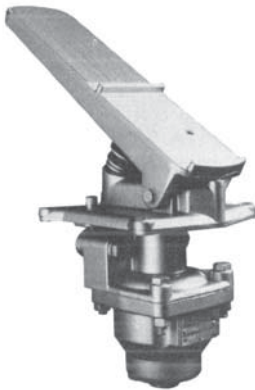

The H-1 CONTROLAIR Valve is a pedal actuated, 3-way pressure regulating valve, suitable for applications where the valve portion extends below the floor level. Depressing the pedal increases the outlet pressure. The pedal is self-returning. This valve is suitable for brake and clutch control or any use where foot operation pressure control is desired.
Approx. weight: 8½ lbs. (3.9 Kg)

PIPE CONNECTIONS:

IN Port - Supply

OUT Port - Delivers graduated pressure in direct proportion to pedal depression.

ORDERING INFORMATION

New Part No.	Old Part No.	Pressure Range psi (bar)
R431002613	P -050208-00001	0-65 (0-4.5)
R431002614	P -050208-00002	0-100 (0-6.9)
R431002615	P -050208-00003	0-125 (0-8.6)
R431002616	P -050208-00004	0-150 (0-10.3)
R431002617	P -050208-00008	0-30 (0-2.1)
R431002981*	P -052570-00001*	0-65 (0-4.5)
R431002982*	P -052570-00002*	0-100 (0-6.9)

* light pedal springs

ADJUSTMENTS

The outlet pressure of a CONTROLAIR Valve for any of its operator positions can be changed by an external adjustment. Changing the pressure for one position, however, changes the pressure for all positions since the pressure differential is fixed for given control spring.

With the operator in minimum pressure position, CONTROLAIR Valves used with brakes, clutches, etc. are adjusted to vent outlet pressure to atmosphere. This adjustment fully vents pressure to atmosphere. This adjustment fully vents pressure from these devices.

With the operator in minimum pressure position, devices are adjusted to maintain a low pressure in the circuit. This adjustment gives instant response at the start of operator movement from that position.

HOW TO ORDER CONTROLAIR® VALVES

To order a CONTROLAIR Valve, specify it by model, by part number, and by the pressure range desired. Example: HC-2-LX CONTROLAIR Valve, Part Number R431002616 with 0-65 psi (0-4.5 bar) pressure range.

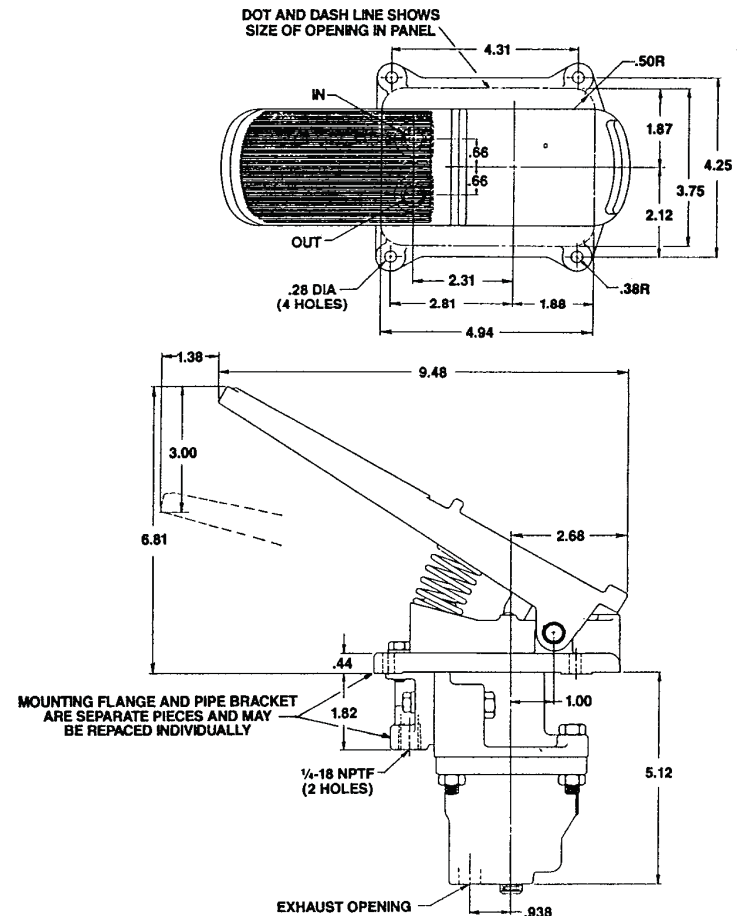

“H” Controlair[®] Valves

H-1 CONTROLAIR[®] VALVE

LIGHT PEDAL FORCE



This economical version of the H-1 operates identically to the standard H1, but has considerably lighter pedal force that makes it especially suited for throttle controls. This model also offers an alternative piping arrangement as the valve portion from the H-2 version is utilized. Formed steel pedal with a rubber tread is utilized on this model.

Approximate weight: 6 lbs. (2.7 Kg)

PIPE CONNECTIONS:

IN Port - Supply

OUT Port - Delivers graduated pressure in direct proportion to pedal depression.

ORDERING INFORMATION

New Part No.	Old Part No.	Pressure Range
R431005617	P -060921-00001	0-65 psi (0-4.5 bar)
R431005618	P -060921-00002	0-100 psi (0-6.9 bar)
R431005619	P -060921-00003	0-125 psi (0-8.6 bar)

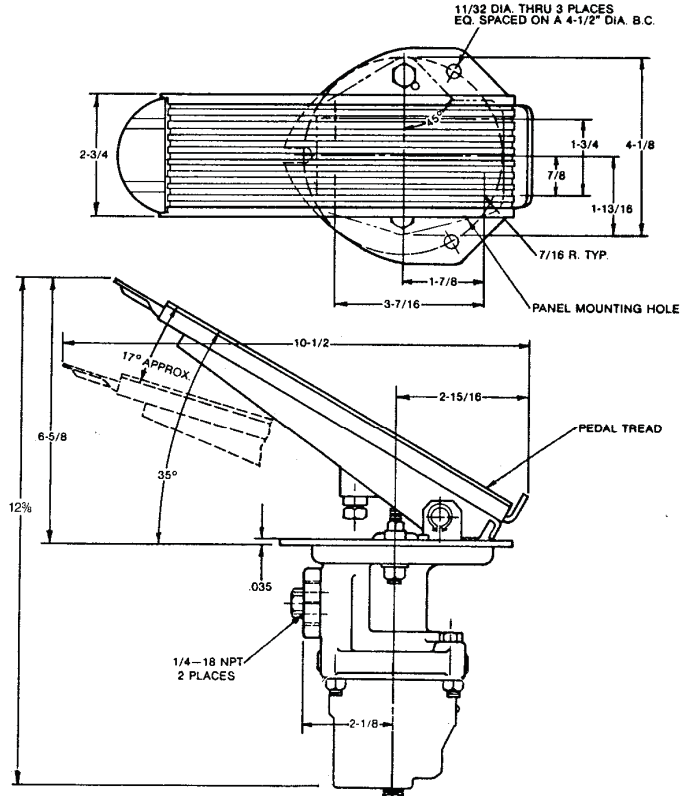

H-1-A CONTROLAIR[®] VALVE

The H-1-A CONTROLAIR Valve is a pedal actuated 3-way pressure regulating valve that is designed for installations in which its

operator is standing or in which part of the valve cannot extend below floor level.

Depressing its pedal increases the outlet pressure. Raising the pedal decreases the outlet pressure. The pedal is self-returning.

This valve is suitable for industrial control and any use where foot operated pressure control is desired.

Approximate weight: 6½ lbs. (2.9 Kg)

PIPE CONNECTIONS:

IN Port - Supply

OUT Port - Delivers graduated pressure in direct proportion to pedal depression.

ORDERING INFORMATION

New Part No.	Old Part No.	Pressure Range
R431003063	P -052971-00001	0-65 psi (0-4.5 bar)
R431003064	P -052971-00002	0-100 psi (0.6.9 bar)
R431003065	P -052971-00003	0-125 psi (0-8.6 bar)
R431003066	P -052971-00004	0-150 psi (0-10.3 bar)

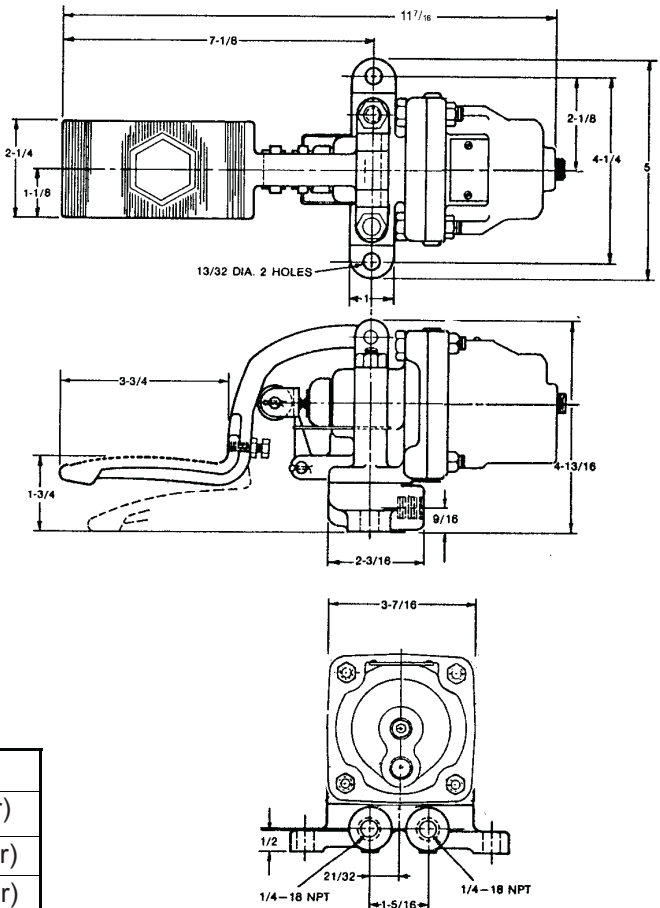

“H” Controlair® Valves

H-2 CONTROLAIR® VALVE



The H-2 CONTROLAIR Valve is a lever operated, 3-way, pressure regulating valve. Air pressure is increased, decreased or maintained at the OUT port according to lever position. Facing the lever side of the valve, clockwise lever movement increases pressure. (see diagram) When the lever remains in one position, the CONTROLAIR Valve maintains outlet pressure

for that position.

For throttle control applications, the valve is set with a pre-load of 10 psi (0.69 bar) and delivery pressure range varies with the valve chosen.

Approximate weight: 6½ lbs. (2.9 Kg)

PIPE CONNECTIONS:

IN Port - Supply

OUT Port - Delivers graduated pressure in direct proportion to clockwise lever travel from minimum pressure position (facing lever side of valve).

MODELS

H-2-X CONTROLAIR Valve - Lever returns to minimum pressure position when released.

H-2-FX CONTROLAIR Valve - Lever remains in the position where released.

H-2-LX CONTROLAIR Valve - Lever returns to minimum pressure position when released from any position except maximum pressure position.

Maximum pressure position is detented.

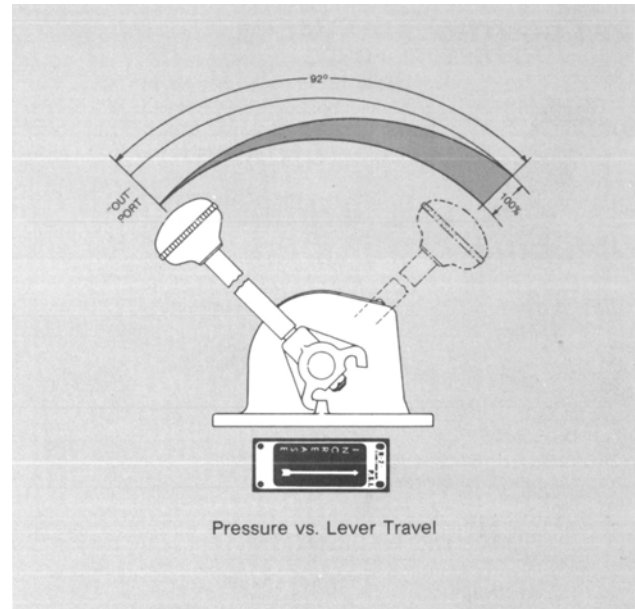

ORDERING INFORMATION

Model	New Part No.	Old Part No.	Pressure Range psi (bar)	“C” Lever Travel
H-2-X	R431002638	P -050493-00001	0-65 (0-4.5)	92°
	R431002639	P -050493-00002	0-100 (0-6.9)	92°
	R431002640	P -050493-00003	0-125 (0-8.6)	92°
	R431002641	P -050493-00004	0-150 (0-10.3)	92°
	R431002642	P -050493-00008	0-30 (0-2.1)	92°
H-2-FX	R431002643	P -050494-00001	0-65 (0-4.5)	92°
	R431002644	P -050494-00002	0-100 (0-6.9)	92°
	R431002645	P -050494-00003	0-125 (0-8.6)	92°
	R431002646	P -050494-00004	0-150 (10.3)	92°
	R431002045	P -050494-00005	0-15 (0-1.1)	92°
	R431002647	P -050494-00008	0-30 (0-2.1)	92°
	R431002648	P -050594-00010	0-80 (0-5.5)	92°
	R431002649	P -050494-00011	10-65 (0.7-4.5)	78°
	R431002650	P -050494-00012	10-90 (0.7-6.2)	78°
R431002651	P -050494-00015	0-175 (0-10.3)	92°	
H-2-LX	R431002652	P -050499-00001	0-65 (0-4.5)	92°
	R431002653	P -050499-00002	0-100 (06.9)	92°
	R431002654	P -050499-00003	0-125 (0-8.6)	92°
	R431002655	P -050499-00004	0-150 (0-10.3)	92°

See page 7 for listing of alternate handle arrangements. Full pressure feature and chrome plated cover details are available on selected models. Consult factory for requirements and part numbers not shown.

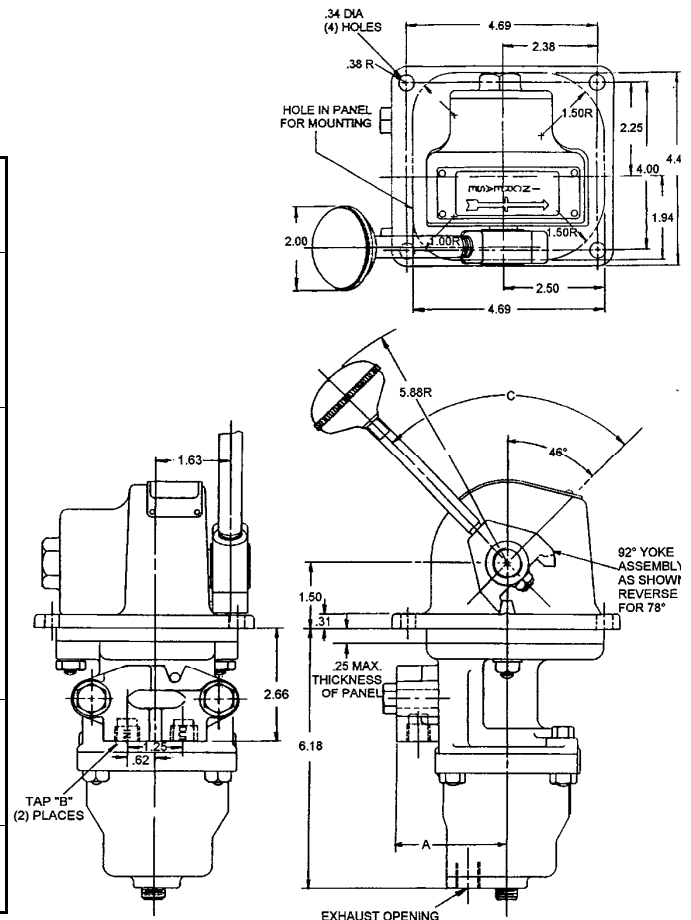

“H” Controlair[®] Valve Models
Alternate H-2 Controlair[®] Valve Models

The following list of H-2 CONTROLAIR[®] valve part numbers is provided for use in those cases where a handle location or a push/pull handle action is required by special control panel configurations. Use standard catalog whenever possible.

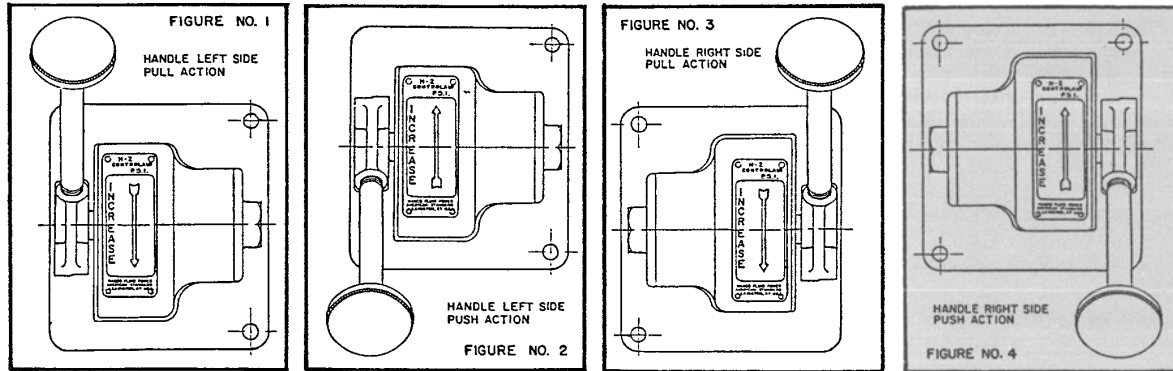

H-2-X CONTROLAIR[®] Valves (spring return)

Model	New P/N	Old P/N	Configuration	Model	New P/N	Old P/N	Configuration
H-2-X	R431007252	P -067694-00003	Figure No. 1 Rev. nameplate Std. cam	H-2-X	R431007324	P -068544-00003	Figure No. 3 Rev. nameplate cam
H-2-X	R431007323	P -068543-00003	Figure No. 2 Std. nameplate Reverse cam	H-2-X	R431002639	P -050493-00002	Figure No. 4 Std. nameplate Std. cam

H-2-X CONTROLAIR[®] Valves
(spring return with detent w/detent)

Model	New P/N	Old P/N	Configuration	Model	New P/N	Old P/N	Configuration
H-2-LX	R431007326	P -068546-00003	Figure No. 1 Rev. nameplate Std. cam	H-2-LX	R431007327	P -068547-00003	Figure No. 3 Rev. nameplate Rev. cam
H-2-LX	R431007325	P -068545-00003	Figure No. 2 Std. nameplate Reverse cam	H-2-LX	R431002653	P -050499-00002	Figure No. 4 Std. nameplate Std. cam

H-2-FX CONTROLAIR[®] Valves (friction holding handle)

Model	New P/N	Old P/N	Configuration	Model	New P/N	Old P/N	Configuration
H-2-FX	R431007308	P -068521-00002	Figure No. 1 Rev. nameplate Std. cam	H-2-FX	R431007329	P -068549-00003	Figure No. 3 Rev. nameplate Rev. cam
H-2-FX	R431007328	P -068548-00003	Figure No. 2 Std. nameplate Reverse cam	H-2-FX	R431002644	P -050494-00002	Figure No. 4 Std. nameplate Std. cam

Shaded areas (*) standard catalog combinations see page 6. Others are non-stock items.

"H" Controlair® Valves H-2-E CONTROLAIR® VALVE



The H-2-EX and H-2-EFX CONTROLAIR Valves are 3-way pressure graduating valves which increase outlet pressures from 0 to 40% of maximum value in the first 60° of lever movement from "OFF" position, and then increases outlet pressure from 40% to maximum value in the remaining 32° of lever movement.

H-2-EX and H-2-EFX CONTROLAIR Valves are used in applications that require closer pressure adjustments at the low end of the outlet pressure range than at the high pressure end of the range.

Typical applications for these valves are the operation of clutches on oil drilling rigs, the control of pressure rolls in rolling mills, and the operation of some clamping cylinders.

Approximate weight: 6½ lbs. (2.9 Kg)

PIPE CONNECTIONS

IN Port - Supply

OUT Port - Delivers graduated pressure when lever is moved clockwise from "Off" (facing lever side of valve). A slow build-up of pressure with 40% of the maximum obtained at 60° of lever travel, then rapid build-up of the remaining 60% of pressure range in the remaining 32° of lever travel.

MODELS

H-2-EX CONTROLAIR Valve - Lever automatically returns to "Off" position when released.

H-2-EFX CONTROLAIR Valve - Lever remains in the position when released.

ORDERING INFORMATION

Model	New Part No.	Old Part No.	Pressure Range psi (bar)
H-2-EX	R431002807	P -050925-00001	0-65 (0-4.5)
	R431002808	P -050925-00002	0-100 (0-6.9)
	R431002809	P -050925-00003	0-125 (08.6)
H-2-EFX	R431002946	P -051846-00001	0-65 (04.5)
	R431002947	P -051846-00002	0-100 (06.9)
	R431002948	P -051846-00003	0-125 (0-8.6)

See page 9 for listing of alternate handle arrangements. Full pressure feature and chrome plated cover details are available on selected models. Consult factory for requirements and part numbers not shown.

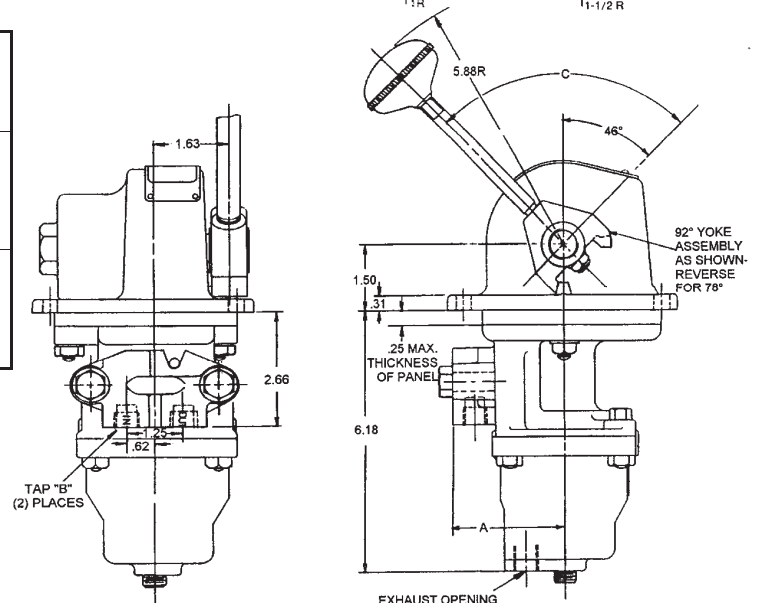
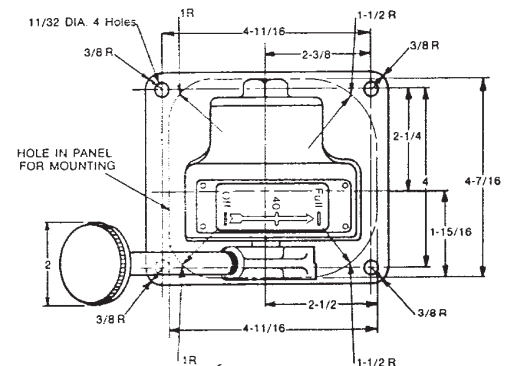
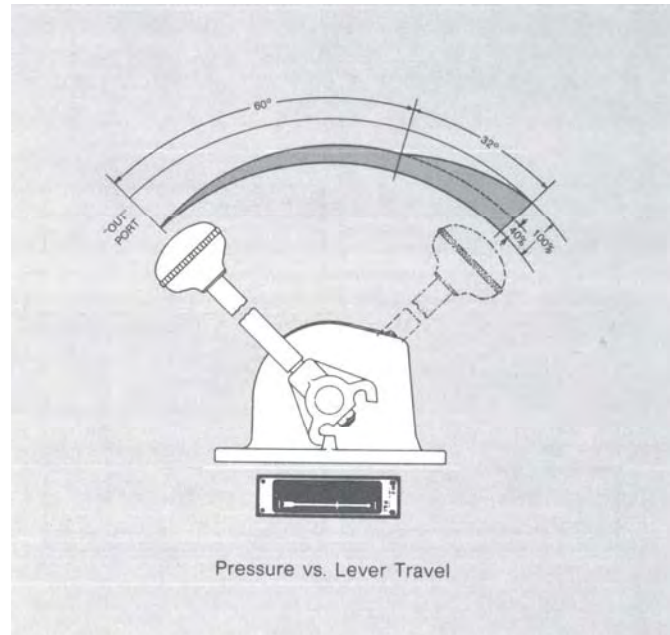

“H” Controlair[®] Valves
H-2-EX CONTROLAIR[®] VALVES Alternate Models

In order to provide maximum flexibility in control panel arrangements, the following alternate models of the H-2-EX CONTROLAIR valve have been established. In general, the four options provide either push or pull action when the valve is mounted so that the handle is on either the left or right. This is particularly attractive with the increased use of vertical control panels where the pull action is easier for the operator.

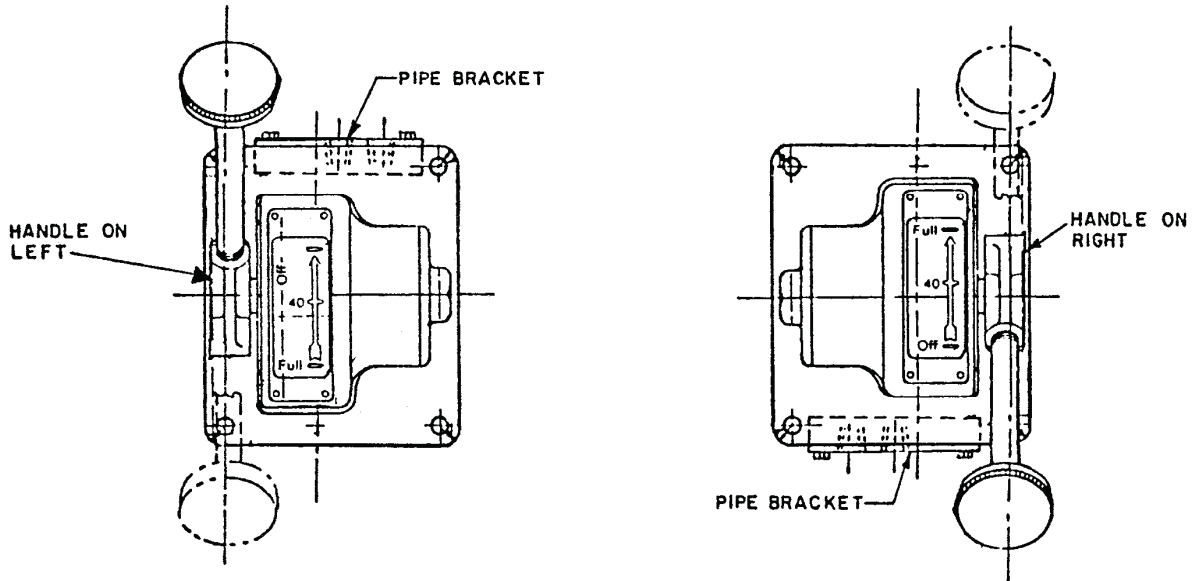

Model	New Part No.	Old Part No.	Action	Details
H-2-EX	R431007222	P -067577-00002	Pull	Reverse nameplate Standard cam
H-2-EX	R431007221	P -067576-00002	Push	Standard nameplate Reverse cam
H-2-EX	R431007033	P -067224-00002	Pull	Reverse nameplate Reverse cam
H-2-EX	R431002808	P -050925-00002	Push	Standard nameplate and cam

*shaded area is standard valve configuration

“H” Controlair® Valves
HC-2 CONTROLAIR® VALVE



The HC-2 CONTROLAIR Valve is a lever operated, pressure regulating, 4-way directional valve. It consists of two 3-way directional valves, and a 3-way pressure regulating portion. The regulating portion furnishes the inlet air for the directional valves. Each directional valve has its own OUT port.

Initial lever movement from “OFF” position selects the “OUT” port to be activated. Further lever movement in the same direction controls the outlet pressure of the air at that port. The opposite OUT port remains connected to atmosphere. (See diagram)

These valves are used to control two clutches, two brakes, a clutch and a brake, two single acting cylinders or a double acting cylinder. In fact, wherever it is desired to control, with one lever, the flow and pressure in one or the other of two separate air lines.

Approximate weight: 9 lbs. (4.1 Kg)

PIPE CONNECTIONS

Port 1 - OUT, graduated pressure when lever is moved clockwise from “Off” (facing lever side of valve).

Port 2 - IN pressure.

Port 3 - OUT, graduated pressure when lever is moved counterclockwise from “Off”.

MODELS

HC-2-X CONTROLAIR Valve - Lever automatically returns to “Off” position when released.

HC-2-FX CONTROLAIR Valve - Lever remains in the position where released. Holding friction is adjustable.

HC-2-LX CONTROLAIR Valve - Lever automatically returns to “Off” position when released from any position except maximum pressure position.

HC-2-SX CONTROLAIR Valve - Detent 10° either side of neutral. Handle latches in one maximum pressure position only. The handle self returns to the NEUTRAL position from the other position in the handle travel arc. Models with latch position in either maximum pressure position are available.

ORDERING INFORMATION

Model	New Part No. (note no.)	Old Part No.	Pressure Range psi (bar)
HC-2-X	R431002835	P -050975-00001	0-65 (0-4.5)
	R431002836	P -050975-00002	0-100 (0-6.9)
	R431002837	P -050975-00003	0-125 (08.6)
	R431002838	P -050975-00004	0-150 (0-10.3)
HC-2-FX	R431002839	P -050976-00001	0-65 (0-4.5)
	R431002840	P -050976-00002	0-100 (0-6.9)
	R431002841	P -050976-00003	0-125 (0-8.6)
	R431002842	P -050976-00004	0-150 (0-10.3)
	R431002843	P -050976-00008	0-30 (0-2.1)
HC-2-LX	R431003824	P -055582-00001	0-65 (0-4.2)
	R431003825	P -055582-00002	0-100 (0-6.9)
	R431003826	P -055582-00003	0-125 (0-8.6)
	R431003827	P -055582-00004	0-150 (0-10.3)
HC-2-SX	R431009114 (1)	P -051206-00001	0-60 (0-4.2)
	R431002892 (1)	P -051206-00002	0-100 (0-6.9)
	R431002893 (1)	P -051206-00003	0-125 (0-8.6)
	R431002894 (1)	P -051206-00004	0-150 (0-10.3)
	R431007030 (2)	P -067197-00003	0-125 (0-8.6)

NOTE:

- (1) Handle detent latches in maximum pressure position away from pipe bracket. (Position “A”)
- (2) Handle detent latches in maximum pressure position on pipe bracket side (Position “B”).
- (3) Full pressure feature, chrome plated cover details, and other special arrangements are available. Consult factory for requirements and part numbers not shown.

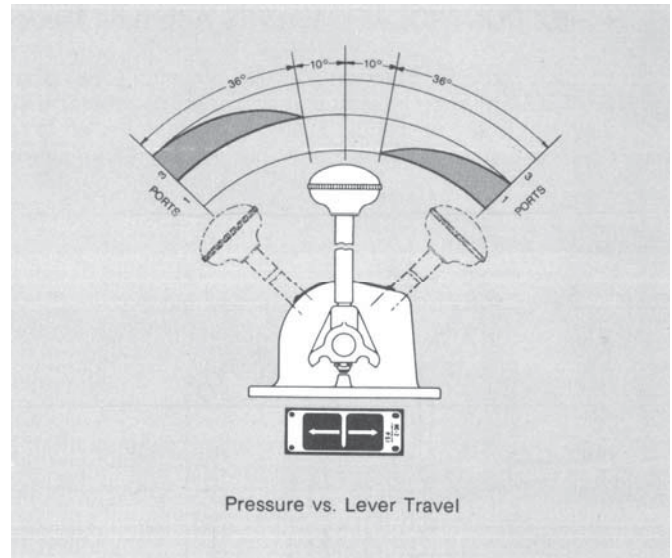

Pressure vs. Lever Travel

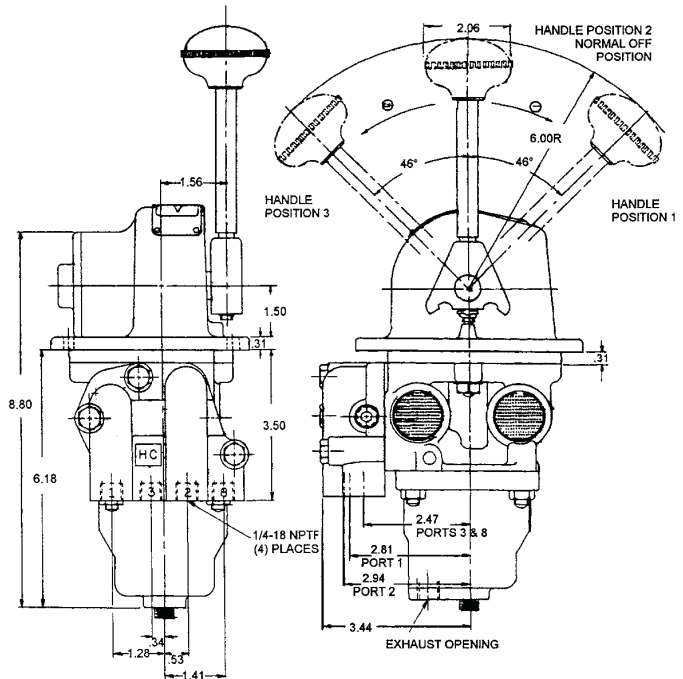
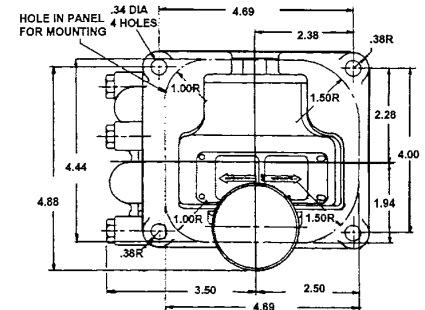

“H” Controlair[®] Valves
HD-2 CONTROLAIR[®] VALVE



The HD-2 CONTROLAIR Valve is a composite lever operated directional valve consisting of two 3-way directional valves and a 3-way pressure regulating portion. Each unit has its own OUT port.

Initial lever movement either side of “Neutral” position activates the OUT port from the pressure regulating portion and one or the other of the ports from the 3-way directional valves. The chosen directional valve port delivers full inlet pressure while the other OUT port remains connected to atmosphere. Further lever movement in the same direction controls the air pressure delivered by the pressure regulating portion. (See diagram)

These valves are used principally to control the forward and reverse clutches and the throttle of an engine. They are also suitable for applications where combined lever-operated direction control and pressure control are desired.

Approximate weight: 9 lbs. (4.1 Kg)

PIPE CONNECTIONS

Port 1 - OUT, full inlet pressure when lever is moved clockwise from “Neutral” (facing lever side of valve).

Port 2 - IN pressure.

Port 3 - OUT, full inlet pressure when lever is moved counterclockwise from “Neutral.”

Port 8 - OUT, graduated pressure when lever is moved in either direction from “Neutral.”

MODELS

HD-2-X CONTROLAIR Valve - The lever returns from the extreme position to the valve’s “Neutral” or “Off” position when the operating force is removed.

HD-2-FX CONTROLAIR Valve - Lever remains in the position where released. Holding friction is adjustable.

HD-2-LX CONTROLAIR Valve - The lever returns to the valve’s “Neutral” or “Off” position when manually moved out of the latch position (extreme travel position).

HD-2-XS CONTROLAIR Valve - Same as HD-2-X models except no graduated pressure delivery from port 8 when handle is moved away from pipe bracket.

ORDERING INFORMATION

Model	New Part No.	Old Part No.	Pressure Range
HD-2-X	R431002831	P -050973-00001	0-65 psi (0-4.5 bar)
	R431002832	P -050973-00002	0-100 psi (0-6.8 bar)
	R431002833	P -050973-00003	0-125 psi (0-8.6 bar)
	R431002834	P -050973-00004	0-150 psi (0-10.3 bar)
HD-2-FX	R431002823	P -050970-00001	0-65 psi (0-4.5 bar)
	R431002824	P -050970-00002	0-100 psi (0-6.9 bar)
	R431002825	P -050970-00003	0-125 psi (0-8.6 bar)
	R431002826	P -050970-00004	0-150 psi (0-10.3 bar)
HD-2-LX	R431002827	P -050972-00001	0-65 psi (0-4.5 bar)
	R431002828	P -050972-00002	0-100 psi (0-6.9 bar)
	R431002829	P -050972-00003	0-125 psi (0-8.6 bar)
	R431002830	P -050972-00004	0-150 psi (0-10.3 bar)
HD-2-XS	R431009025	P -067556-00001	0-65 psi (0-4.5 bar)

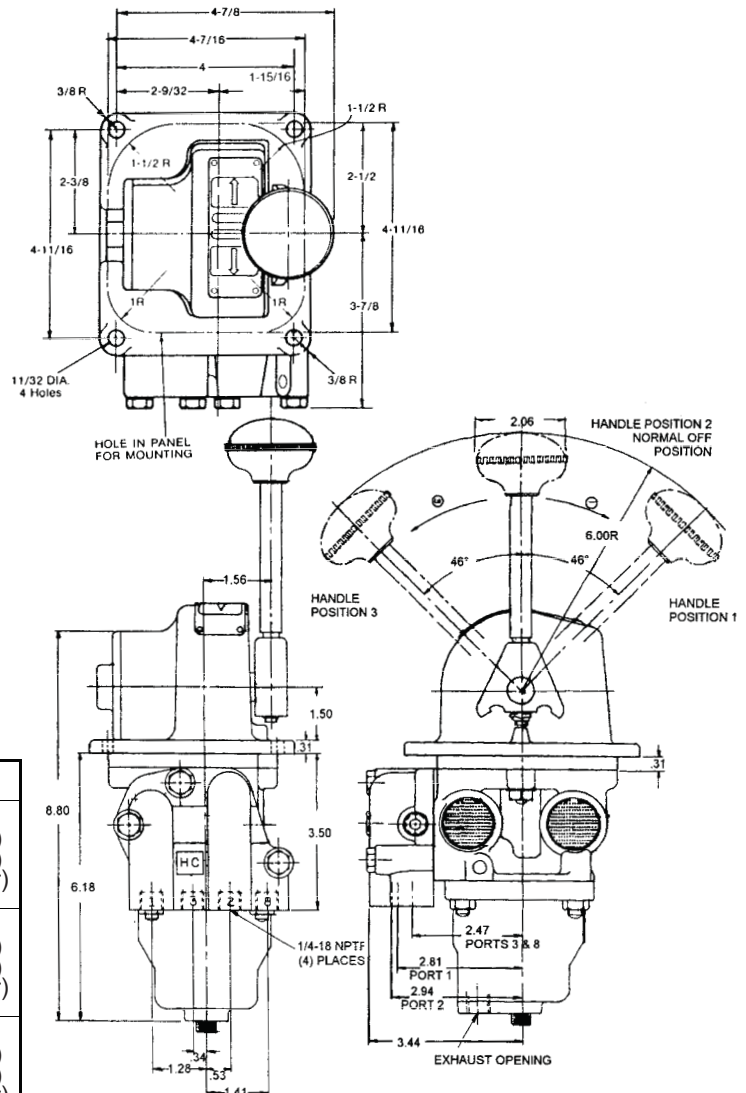
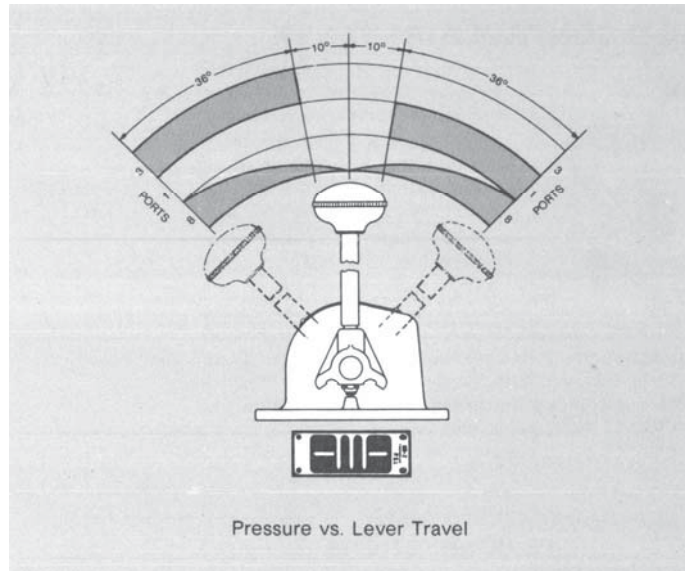

Full pressure feature, chrome plated cover details, and other special operating details are available. Consult factory for requirements and part numbers not shown.

“H” Controlair® Valves
HE-2 CONTROLAIR® VALVE



The HE-2 CONTROLAIR Valve is a composite lever operated directional valve consisting of a 3-way directional valve and a 3-way pressure regulating portion with each unit having its own OUT port.

The first 10° of lever travel from the “Off” position opens the directional valve to provide full inlet pressure for its OUT port. Further lever-travel controls the pressure of the air delivered by the pressure regulating portion. This graduated pressure varies directly with lever travel. (See diagram)

These valves are used principally in the control of a clutch and a throttle of an engine.

Approximate weight: 9 lbs. (4.1 Kg)

PIPE CONNECTIONS

Port 1 - OUT, full inlet pressure when lever is moved 10° clockwise from “Off” (facing lever side of valve).

Port 2 - IN pressure.

Port 8 - OUT, graduated pressure when lever is moved clockwise from “Off”.

MODELS

HE-2-X CONTROLAIR Valve - The lever returns from the extreme position to the valve’s “clutch” or “Off” position when the operating force is removed.

HE-2-FX CONTROLAIR Valve - Lever remains in the position where released. Holding friction is adjustable.

HE-2-LX CONTROLAIR Valve - The lever returns to the valve’s “Neutral” or “Off” position when manually moved out of the latch position (extreme travel position).

ORDERING INFORMATION

Model	New Part No.	Old Part No.	Pressure Range psi (bar)
HE-2-X	R431002937	P -051692-00001	0-65 (0-4.5)
	R431002938	P -051692-00002	0-100 (0-6.9)
	R431002939	P -051692-00003	0-125 (0-8.6)
HE-2-FX	R431002912	P -051612-00001	0-65 (0-4.5)
	R431002913	P -05161200002	0-100 (0-6.9)
	R431002914	P -051612-00003	0-125 (0-8.6)
	R431002915	P -051612-00004	0-150 (0-10.3)
HE-2-LX	R431002916	P -051614-00001	0-65 (0-4.5)
	R431002917	P -051614-00002	0-100 (0-6.9)
	R431002918	P -051614-00003	0-125 (0-8.6)

Full pressure feature, chrome plated cover details, and other special operating details are available. Consult factory for requirements and part numbers not shown.

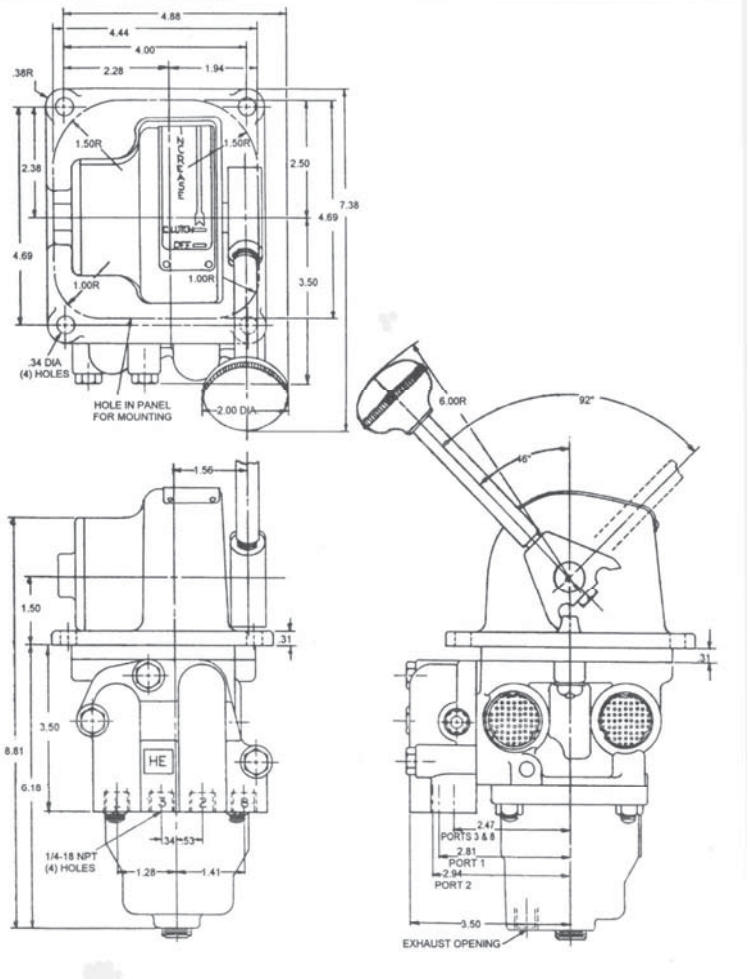
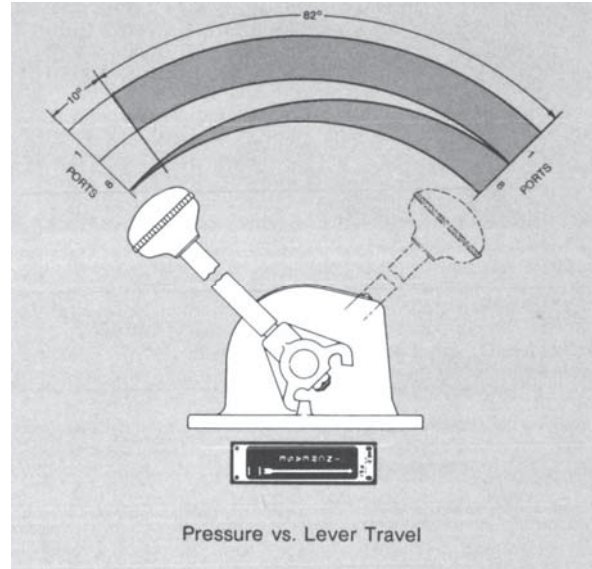

“H” Controlair[®] Valves
H-3 CONTROLAIR[®] VALVE and H-3-G CONTROLAIR[®] VALVE



H-3 CONTROLAIR[®] VALVE

The H-3 CONTROLAIR Valve is equipped with a roller for operation by a cam or a similar mechanical device. Graduated pressure is obtained from the valve's OUT line. Total movement is approximately 5/16" (8mm) with the initial 1/16" (1.6 mm) travel used to

close its exhaust valve.

Approximate weight: 4½ lbs. (2.0 Kg)

ORDERING INFORMATION

New Part No.	Old Part No.	Pressure Range psi (bar)
R431002626	P -050382-00001	0-65 (0-4.5)
R431002627	P -050382-00002	0-100 (0-6.9)
R431002628	P -050382-00003	0-125 (0-8.6)
R431002629	P -050382-00004	0-150 (0-10.3)
R431002630	P -050382-00006	0-25 (0-1.7)
R431002631	P -050382-00008	0-30 (0-2.1)
R431002632	P -050382-00009	0-75 (0-5.2)

Some special models are available. Consult factory for requirements and part numbers not shown.

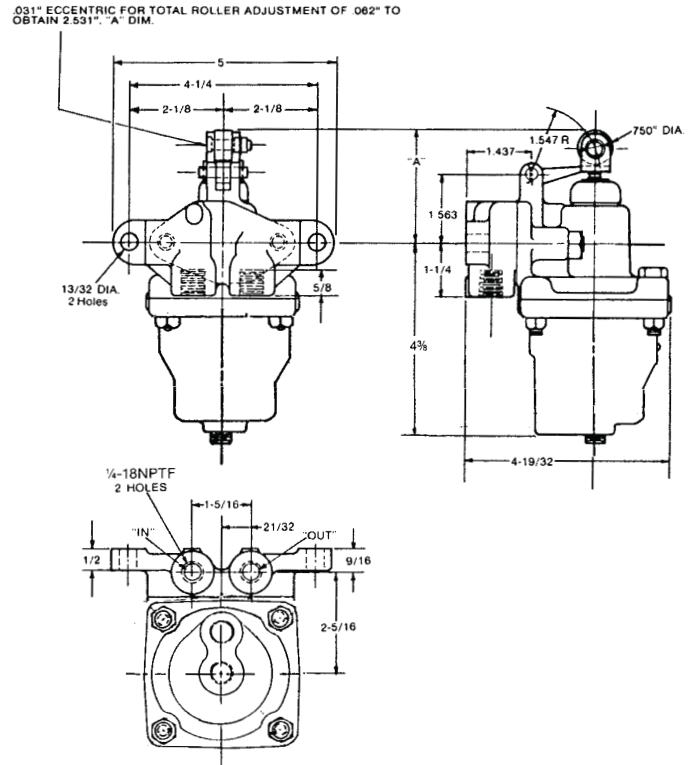

H-3-G CONTROLAIR[®] VALVE

This design is similar to the H-3 CONTROLAIR except the spring housing area is sealed and control pressure can be introduced through the tapped exhaust port to the underside of the diaphragm. By varying this signal, the output of the H-3-G CONTROLAIR can be biased or adjusted in proportions. This bias signal must be lower than the output signal.

ORDERING INFORMATION

New Part No.	Old Part No.	Pressure Range psi (bar)
R431009131	P -052550-00008	0-30 (0-2.1)

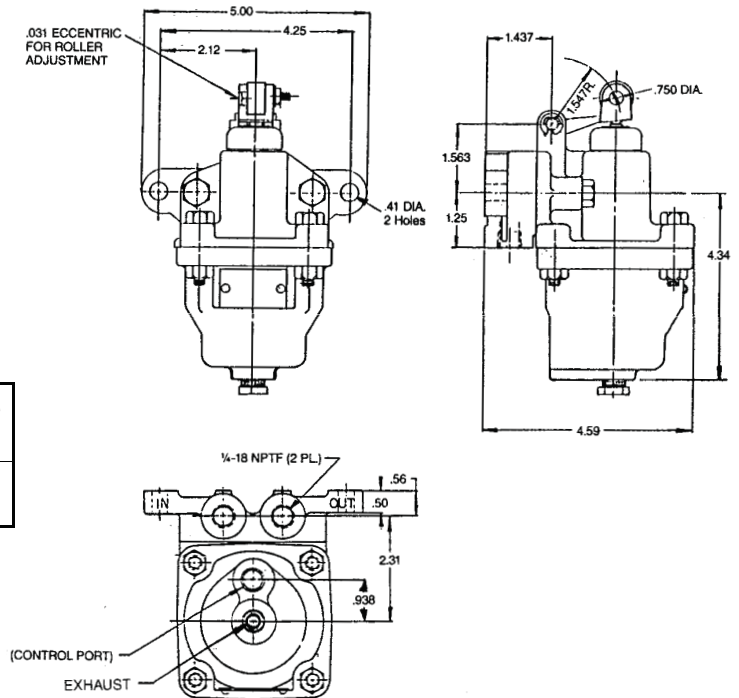

“H” Controlair® Valves
H-4 CONTROLAIR® VALVE and H-4-G CONTROLAIR® VALVE

H-4 CONTROLAIR® VALVE



The H-4 CONTROLAIR Valve is a knob operated, 3-way pressure regulating valve. Arranged for panel mounting, this valve gives fine, vernier type pressure control in one delivery line. The knob holds in all positions and has adjustable stops to limit maximum and minimum travel.

Clockwise rotation of the knob increases pressure in the standard models. Opposite knob action is available. Approximate weight: 5½ lbs. (2.5 Kg)

ORDERING INFORMATION

New Part No.	Old Part No.	Pressure Range psi (bar)
R431002818	P -050967-00001	0-65 (0-4.5)
R431002819	P -050967-00002	0-100 (0-6.9)
R431002820	P -050967-00003	0-125 (0-8.6)
R431002821	P -050967-00004	0-150 (0-10.3)
R431002822	P -050967-00008	0-30 (0-2.1)
R431002885 (1)	P -051173-00001	0-65 (0-4.5)
R431002886 (1)	P -051173-00002	0-100 (0-6.9)

- (1) Counterclockwise rotation increases pressure.
- (2) Consult factory for requirements and part numbers not shown.

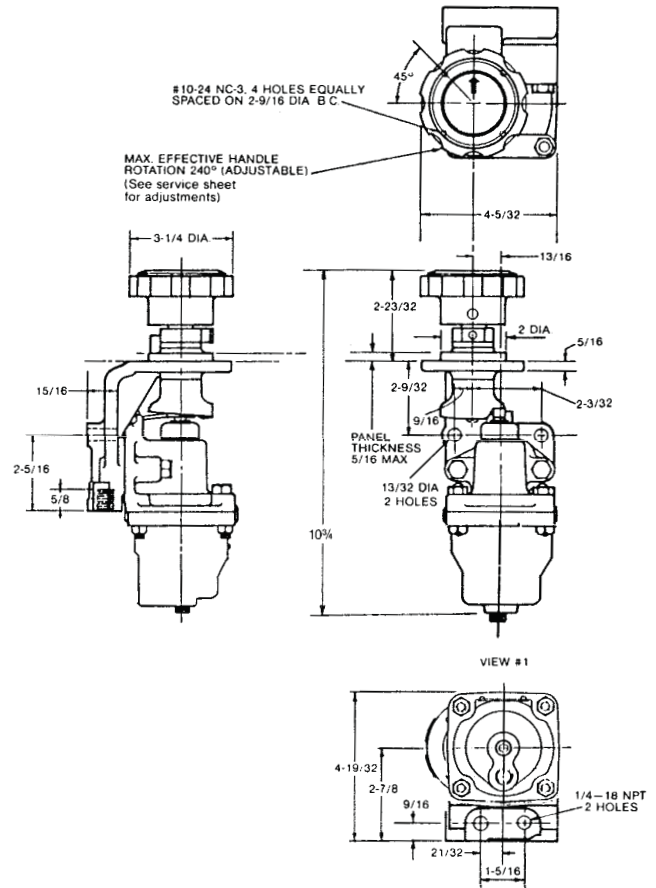

H-4-G CONTROLAIR® VALVE

This design is similar to the H-4 CONTROLAIR except the spring housing area is sealed and a control signal can be introduced under the diaphragm through the tapped exhaust port. The delivery pressure is then biased (decreased) by this signal. The bias signal must always be lower than the output signal called for by the knob travel.

ORDERING INFORMATION

New Part No.	Old Part No.	Bias Range psi (bar)
R431002962	P -052035-00001	0-65 (0-4.5)
R431002963 (1)	P -052035-00002	0-65 (0-4.5)

- (1) 9/16-18 Standard Thread Ports

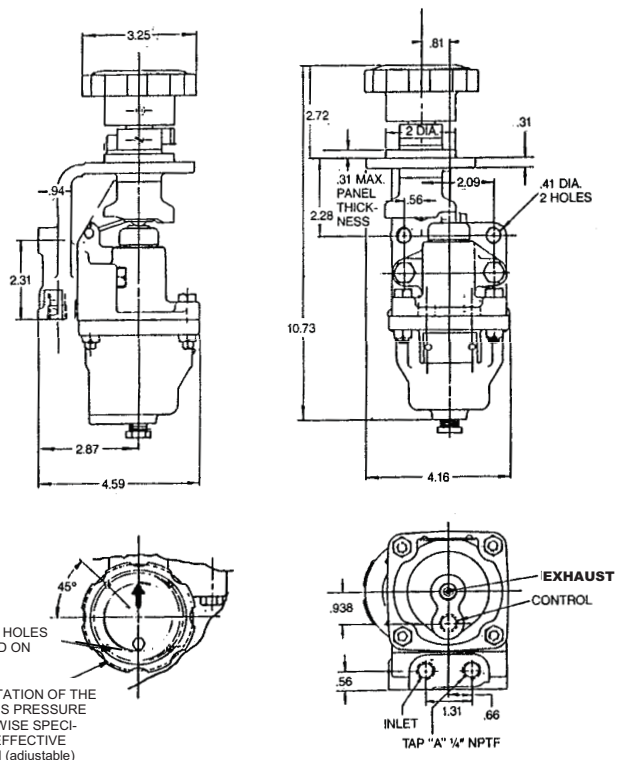

CLOCKWISE ROTATION OF THE KNOB INCREASES PRESSURE UNLESS OTHERWISE SPECIFIED 240° MAX. EFFECTIVE KNOB ROTATION (adjustable)

**“H” Controlair® Valves
REPAIR KIT LIST**

REPAIR KIT LIST

VALVE PORTION KITS

New Part No.	Old Part No.	Description
R431003895	P -055687-K0000	For All Models: Kit, graduating valve (except H-3-G and H-4-G models) (lapped set of inlet and exhaust valve unit, exhaust valve seat, diaphragm, and O rings)
R431003896	P -055687-K0002	
R431004887	P -059028-K0000	For H-1, H-1-A, H-2, H-3, and H-4 Models: (except H-3-G and H-4-G models) Kit, major, valve portion (R431003895 kit, gaskets and strainers, exh. valve spring, dirt protector, O rings, cam dog)
R431003743	P -055474-K0002	For HC-2, HD-2 and HE-2 Models: Kit, minor, side valve (inlet valve assembly and seals)
R431003985	P -057094-00001	
R431004005	P -057136-00000	Kit, major, graduating valve (R431003895 kit, gaskets and strainers, exhaust valve spring, O rings, cam dog)
R431006521	P -064894-00002	Kit, major, valve portion, HC-2 and HD-2 models (R431004005 kit and (2) R431003985 kits)
R431006522	P -064894-00003	

These kits contain some common parts to renew the valve portions only. For severely worn or damaged valve portions, select additional parts from appropriate service bulletins. All kits contain a small tube of recommended lubricant.

MECHANICAL OPERATOR KITS

New Part No.	Old Part No.	Description
R431006425	P -064421-K0000	Kit, knob (H-4) (knob, screw, escutcheon plates)
R431006415	P -064421-00001	Kit, latch springs (-LX, -LS, HD-2-FX models)
R431006418	P -064421-00004	Kit, handle and cam shaft (HC-2-X, HC-2-LX, HD-2-X, HD-2-LX models)
R431006419	P -064421-00005	Kit, handle and cam shaft (HC-2-X, HC-2-LX, HD-2-X, HD-2-LX models)
R431006420	P -064421-00006	Kit, handle and cam shaft (H-2 and HE-2 models except H-2-EX) cam shaft yoke, handle, knob, bearings, cap nut)
R431006421	P -064421-00007	Kit, knob and cam (H-4) (R431006425 kit and new cam details)
R431006422	P -064421-00008	Kit, return spring (H-2 and HE-2 models) (spring and arbor) (except H-2-EX models)
R431006423	P -064421-00009	Kit, return spring (HC-2 and HD-2 models) (spring and arbor)
R431006424	P -064421-00010	Kit, return spring (H-2-EX models) (spring and arbor)
R431006648	P -065636-00000	Kit, roller operator on H-3 model (roller lever assembly, pin and retainers)
R431000597	P -026205-00000	Kit, pedal replacement for H-1 (replaces obsoleted pedal 526474)

The above are some common kits for the repair of the mechanical operating portions of the valves. For severely worn or damaged valves, select model and parts from the appropriate service bulletins. Most service bulletins are available on line at: www.aventics.com/us

AVENTICS Flexair® Valve

Precise control of cylinders, clutches, or other pneumatic equipment is possible through the FLEXAIR Valve. The FLEXAIR Valve is especially useful to control oil drilling rigs, excavating machinery, hoists, dredges, production machines, and special purpose equipment.

As the handle is moved forward, a definite and precise outlet pressure is delivered. If downstream pressure drops, the FLEXAIR will compensate to maintain outlet pressure (without further handle movement). The handle may be moved forward, backward, to one side, or in combination of directions to control pressure in one or two of the three outlet ports. Handle movement forward or backward provides air pressure proportional to handle movements; handle movement to one side operates an on-off valve. Handle guides can be included in the valve to limit handle movement to certain areas or to control sequencing.

Although most valves operate as described above, any of the three directions can deliver a pressure proportional to handle travel (pressure control valve), control an on/off (3-way) valve, or have no valve at all. Forward movement controls valve #1, backward movement controls valve #2, and sideward movement controls valve #3. When used for pressure graduation, valves #1 and #2 deliver and maintain a more precise outlet pressure than the valve in cavity #3.

The handle is available in two lengths. Either handle length can be spring returned or detented. Short handles can include an adjustable friction option.

OPERATION

Pressure Graduating Valves: The precise pressure control of the FLEXAIR Valve, and its ability to change outlet pressure in small increments is obtained through the use of a spring balanced piston. With the handle in the center position, the inlet valve is held closed by the inlet spring. The outlet port is connected to atmosphere through the hollow plunger in the inlet valve. When the handle is moved, the exhaust valve moves down to seal off the exhaust port. Further movement unseats the inlet valve to connect the inlet port to the outlet port and the underside of the piston. Air pressure builds up in the outlet line and underneath the piston. When the air pressure (working on the piston's area) overcomes a spring on top of the piston, the inlet valve seats.

Further movement of the handle to increase pressure depresses the valve assembly, and



again opens the supply valve. Pressure is increased in the outlet line and below the piston until another balanced condition occurs at the higher pressure.

Movement of the handle to decrease pressure decreases the force on the valve assembly, and allows the air pressure and return spring to raise the piston and unseat the exhaust valve. Pressure is therefore vented from the outlet line until it is reduced to the value called for by the handle position.

Should leakage or a temperature variation occur that would change the outlet line pressure called for by the handle position, this deviation in pressure opens either the inlet valve or exhaust valve to restore the correct pressure.

3-Way Valves: With the handle in the center position, the inlet valve is held closed by the inlet spring. The outlet port is connected to atmosphere through the hollow plunger. When the handle is moved, the exhaust valve moves down to seal off the exhaust port and unseat the inlet valve. The inlet pressure then pressurizes the outlet port to full pressure.

Movement of the handle back to center posi-

**AVENTICS Flexair[®] Valve
Construction Features**

CONSTRUCTION FEATURES

MATERIALS - Packing rings and valve seats are oil resistant. Principal metal parts are anodized aluminum, stainless or plated steel.

SIZE - Weighing approximately 6 pounds (2.7 bar), the FLEXAIR Valve is easily grouped because of compact size and lend themselves to manifold supply connections. They may be used as either "right-hand" or "left-hand" valves for side motion.

INTERNAL DIRT PROTECTION - 300-micron strainers in cavities #1 and #2 keep dirt and foreign matter from entering the valving.

VALVE COMBINATIONS - The FLEXAIR Valve contains three valve cavities. Either or both of cavities #1 and #2 may be assembled with balanced 3-way pressure graduating valves with several variations. These variations are as follows:

1. Pressure Graduating - a choice of four sizes of graduating springs which provide a constant rate of pressure buildup as the handle is moved toward its maximum pressure position. (See OPERATIONAL DATA for pressure ranges).
2. Full Pressure Setting - an adjustable setting is available on all graduating valves which provides full inlet pressure to the outlet line at predetermined positions in the handle travel. (See graph below).
3. Preset Pressure - Graduating valves may have a non-retained preload to give a predetermined pressure at the beginning of handle travel. (See graph below)
4. 3-Way Valve - A non graduating valve that delivers full pressure at the beginning of handle travel.

Valve cavity #3, if desired, may contain either a 3-way non-graduating valve or a 3-way graduating valve that is less sensitive than those in cavities #1 and #2. This graduating valve can also have a full pressure setting. (See OPERATIONAL DATE for pressure ranges)

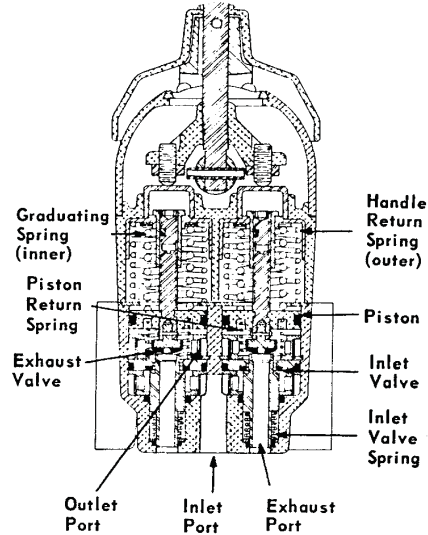

COVER COMBINATIONS - A wide range of handle guide inserts are available to limit handle travel to certain areas. (See page 18)

HANDLE TYPES - Three types of handle return or holding functions are available:

1. Detent - The handle, when released, returns to its center position from all positions except extreme travel (fully applied) for valve cavities #1 and #2. A detent holds the handle in the two fully applied positions for valve cavities #1 and #2. This detent force is adjustable.
2. Friction - The handle will remain in any applied position for valve cavities #1 and #2 when released. This friction is adjustable. (For short handle only)
3. Spring Returned - Handle returns to its center position from all positions when released.

MOUNTING - All FLEXAIR Valve bodies have two sets of 3/8" tapped mounting holes so that it can be mounted for either right-hand or left-hand operation of the side valve (cavity #3). A panel mounting kit is also available (see outline drawing, page 21). Inlet port is 1/2" NPT and the three outlet ports are 1/4" NPT.

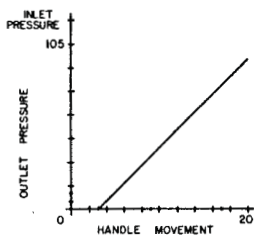

**GRADUATION WITHOUT
FULL PRESSURE**

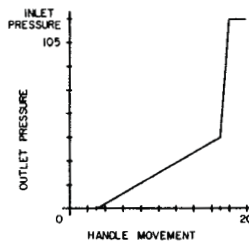

**GRADUATION WITH
FULL PRESSURE**

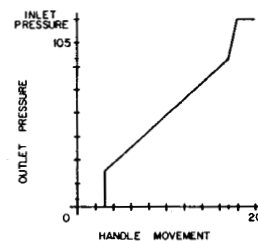

**PRESET WITH
FULL PRESSURE**

**AVENTICS Flexair® Valve
Operational Data**

**OPERATIONAL DATA
PRESSURES**

Maximum Inlet Pressure - 150 psi (10.3 bar)
Maximum Outlet Pressures:

CAPACITY (Valve Cavities #1 & #2)

As shown by the graph the FLEXAIR Valve has been designed to give maximum capacity flow to speed operations.

**GRADUATING VALVES
CAVITIES #1 & #2**

(Operation toward or away from operator)

	Short Handle	Long Handle
With Full Pressure Setting	0-40 psi (0-2.8 bar) 0-50 psi (0-3.4 bar) 0-70 psi (0-4.8 bar) 0-95 psi (0-6.6 bar)	0-45 psi (0-3.1 bar) 0-60 psi (0-4.1 bar) 0-80 psi (0-5.5 bar) 0-110 psi (0-7.6 bar)
Without Full Pressure Setting	0-50 psi (0-3.4 bar) 0-65 psi (0-4.5 bar) 0-90 psi (0-6.2 bar) 0-120 psi (0-8.3 bar)	0-55 psi (0-3.8 bar) 0-75 psi (0-5.2 bar) 0-100 psi (0-6.9 bar) 0-135 psi (0-9.3 bar)

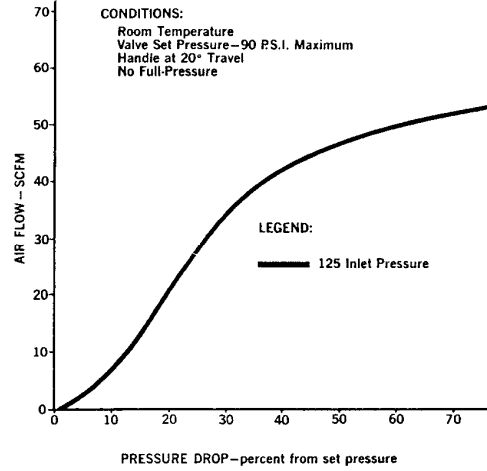

Side Graduating Valve: Cavity #3)

With full pressure setting:

0-40 or 0-70 psi (0-2.8 or 0-4.8 bar)

Without full pressure setting:

0-65 or 0-100 psi (0-4.5 or 6.9 bar)

MAXIMUM TEMPERATURE

-40° to +160°F (-40°C to +71°C)

To determine flow, project up from the PRESSURE DROP Scale (permissible difference between set pressure and outlet pressure under flow conditions) to the curve. At this intersection, project to the left for the resulting flow on the vertical scale.

HANDLE GUIDE INSERTS

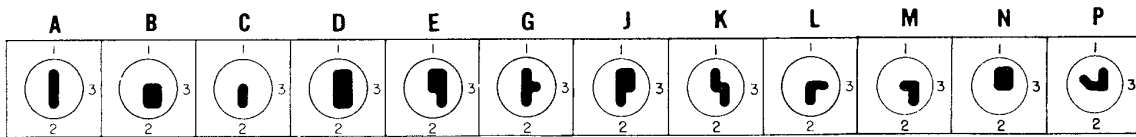

INSERT VALVE CAVITIES ACTUATED

- A #1 & #2 separately
- B #2 & #3 separately or simultaneously
- C #2 only
- D #1, #2, & #3 separately;
#1 & #3 or #2 & #3 simultaneously
- E #1 & #3 separately or simultaneously; #2 after #3
- G #1, #2, and #3 separately
- J #1, #2, and #3 separately
#1 & #3 simultaneously
- K #1 & #3 separately; #2 after #3
- L #2 & #3 separately
- M #3 separately; #2 after #3
- N #1 & #3 separately or simultaneously
- P #3 separately; #1 partially; #1 fully after #3

**AVENTICS Flexair[®] Valve
Designation Code**

DESIGNATION CODE

EXAMPLE:

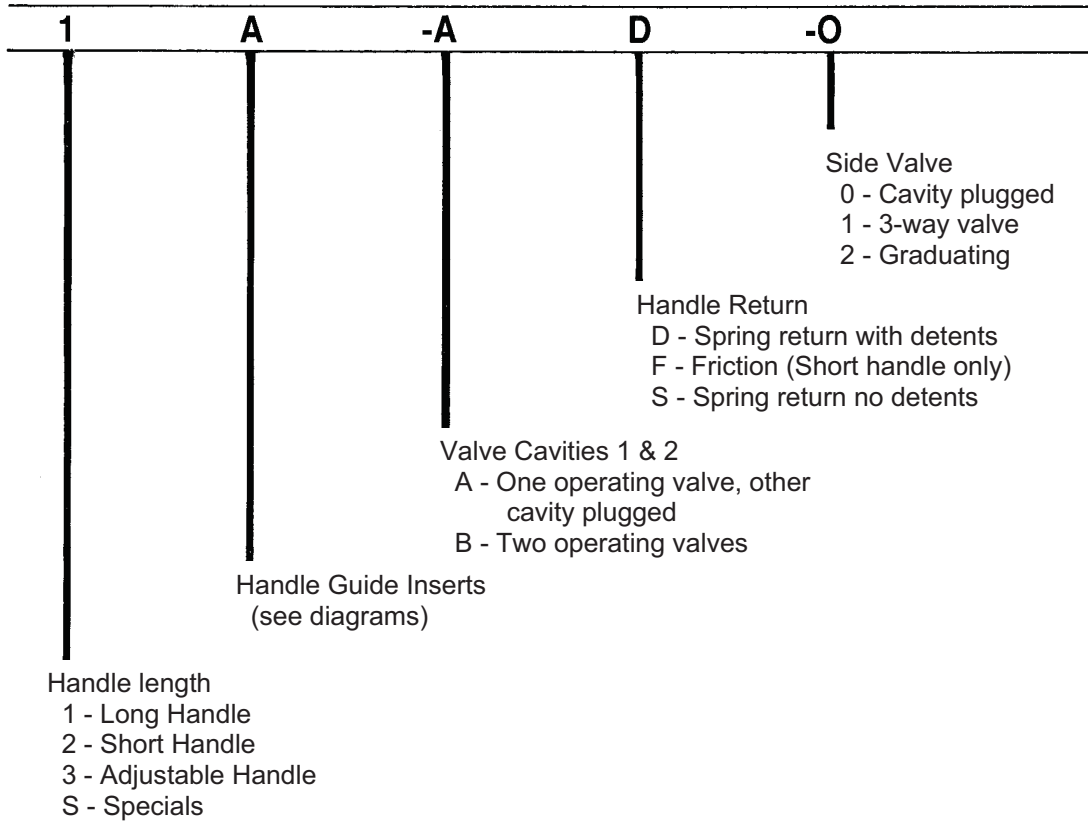

HOW TO ORDER

GIVE DESIGNATION CODE

GIVE ADDITION DESCRIPTION

By giving the proper designation code, the following items are specified:

- (a) Handle length
- (b) Handle guide insert
- (c) Number of graduating valves
- (d) Handle return function
- (e) With or without side valve and type

In addition to the designation code give description of pressures required and special settings, if any, as follows:

- (a) Specify pressure range of graduating valve No. 1 (port 1) & No. 2 (port 2)
- (b) Specify pressure range of side graduating valve, if desired
- (c) Specify preloads, and/or full pressure setting for valves in cavities #1 and #2, if desired.
- (d) Specify panel mounting kit, if required. Kit Part Number R431003027 (Old P -052875-K0000). Not factory installed.
- (e) Specify exhaust adapter kits for cavities 1 & 2 only. Kit Part Number R431005757 (Old P -061340-K0000) Not factory installed)

AVENTICS Flexair® Valve

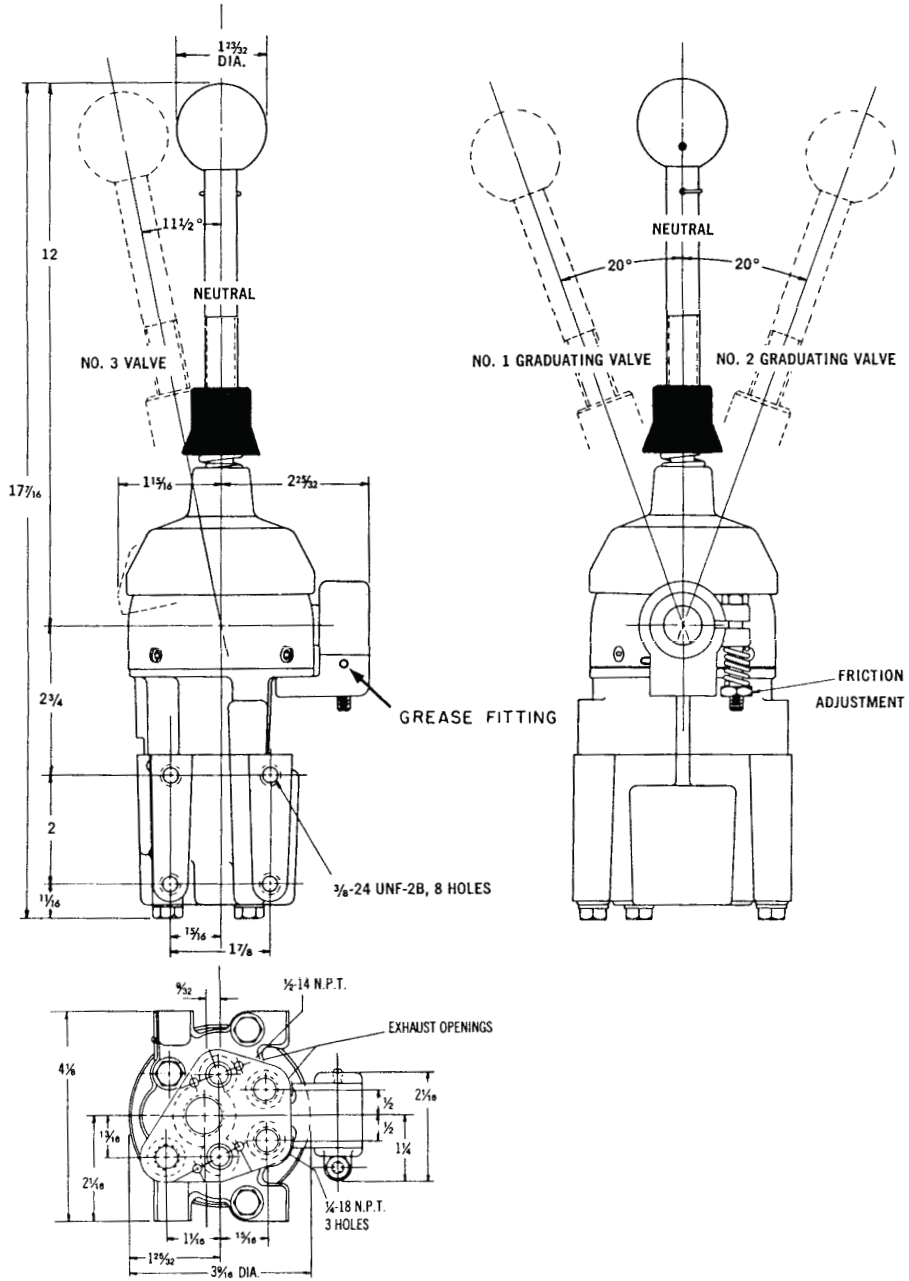

If dimensions are critical, ask for their certification.

FRICION TYPE

AVENTICS Flexair[®] Valve

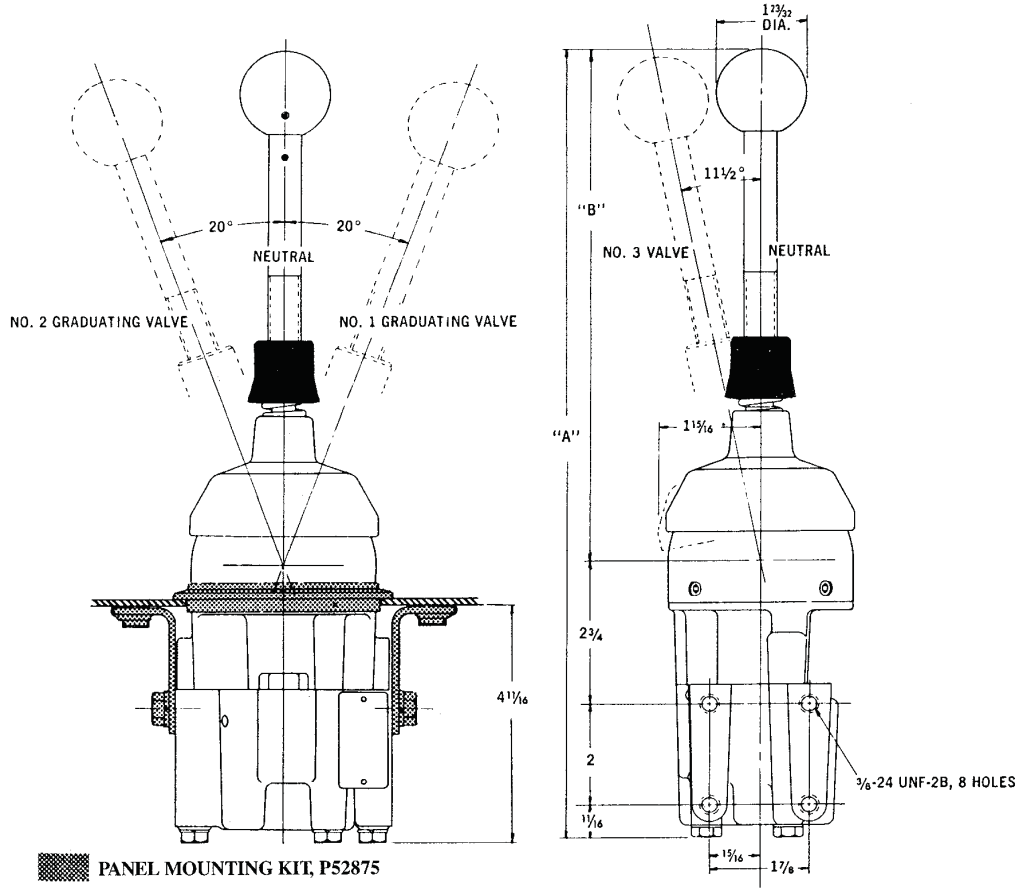

PANEL MOUNTING KIT, P52875
(optional)

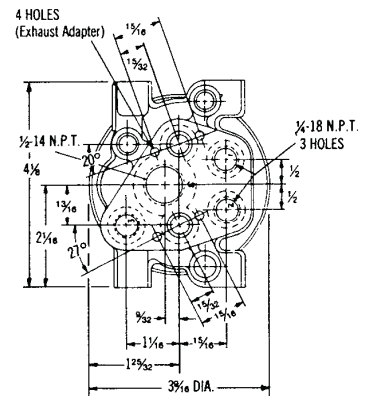
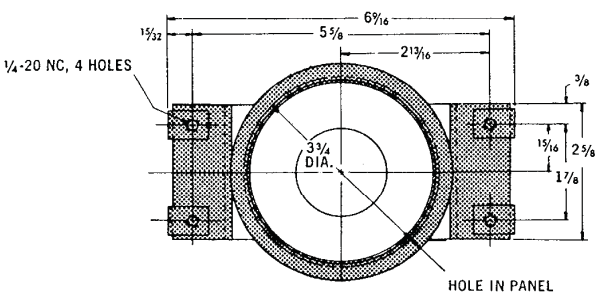

Handle	"A"	"B"
Long	26 5/16"	20 7/8"
Short	17 1/16"	12"

If dimensions are critical, ask for their certification.

SPRING RETURNED & DETENT TYPE

AVENTICS Flexair[®] Valve

REPAIR AND CONVERSION KITS

Major repair kits, which include applicable kits, are listed by the part number of each valve in the “Part Number Index.” When these kits are installed as recommended, the result is a fully rebuilt and current Flexair[®] Valve.

When partial repairs are desired, the **basic repair kits** that follow should provide adequate selection. All major kits for Flexair Valves are made up from these six basic kits. The major kits listed in the index are identified here by valve model designation and show the basic kits they include.

MAJOR REPAIR KITS

WHEN DIGITS ARE:	QTY.	DESCRIPTION	PC. NO.
D - A or - Q F	1 1 1	REPAIR KIT, Major REPAIR KIT, Common Parts REPAIR KIT, Detent REPAIR KIT, Cavities 1 & 2	R431004962
- A S - Q	1 1	REPAIR KIT, Major REPAIR KIT, Common Parts REPAIR KIT, Cavities 1 & 2	R431004963
D - B or - Q F	1 1 2	REPAIR KIT, Major REPAIR KIT, Common Parts REPAIR KIT, Detent REPAIR KIT, Cavities 1 & 2	R431004964
- B S - Q	1 1	REPAIR KIT, Major REPAIR KIT, Common Parts REPAIR KIT, Cavities 1 & 2	R431004965
D 1 - A or - or F 2	1 1 1 1	REPAIR KIT, Major Use kit P59301-0012 when cavity 3 is 3-way Use kit P59301-0012 when cavity 3 graduated REPAIR KIT, Common Parts REPAIR KIT, Detent REPAIR KIT, Cavities 1 & 2 REPAIR KIT, Cavity 3	P59301-0004 (OBS.)
1 - A S - or 2	1 1 1	REPAIR KIT, Major Use kit P59301-0014 when cavity 3 is 3-way Use kit P59301-0015 when cavity 3 graduated REPAIR KIT, Common Parts REPAIR KIT, Cavities 1 & 2 REPAIR KIT, Cavity 3	P59301-0005 (Obs.)
D 1 - B or - or F 2	1 2 1	REPAIR KIT, Major Use kit P59301-0016 when cavity 3 is 3-way Use kit P59301-0017 when cavity 3 graduated REPAIR KIT, Common Parts REPAIR KIT, Detent REPAIR KIT, Cavities 1 & 2 REPAIR KIT, Cavity 3	P59301-0006 (OBS.)
1 - B S - or 2	1 1 1	REPAIR KIT, Major Use kit P59301-0018 when cavity 3 is 3-way Use kit P59301-0019 when cavity 3 graduated REPAIR KIT, Common Parts REPAIR KIT, Cavities 1 & 2 REPAIR KIT, Cavity 3	P59301-0007 (Obs.)
D 1 - A or - or F 2	1 1 1 1	REPAIR KIT, Major Use kit P59301-0012 when cavity 3 is 3-way Use kit P59301-0013 when cavity 3 graduated REPAIR KIT, Common Parts REPAIR KIT, Detent REPAIR KIT, Cavities 1 & 2 CONVERSION KIT, Cavity 3	P59301-0008 (OBS.)

WHEN DIGITS ARE:	QTY.	DESCRIPTION	PC. NO.
1 - A S - or 2	1 1 1	REPAIR KIT, Major Use kit P59301-0014 when cavity 3 is 3-way Use kit P59301-0015 when cavity 3 graduated REPAIR KIT, Common Parts REPAIR KIT, Cavities 1 & 2 REPAIR KIT, Cavity 3	P59301-0009 (Obs.)
D 1 - B or - or F 2	1 1 2 1	REPAIR KIT, Major Use kit P59301-0016 when cavity 3 is 3-way Use kit P59301-0017 when cavity 3 graduated REPAIR KIT, Common Parts REPAIR KIT, Detent REPAIR KIT, Cavities 1 & 2 CONVERSION KIT, Cavity 3	P59301-0010 (OBS.)
1 - B S - or 2	1 1 1	REPAIR KIT, Major Use kit P59301-0018 when cavity 3 is 3-way Use kit P59301-0019 when cavity 3 graduated REPAIR KIT, Common Parts REPAIR KIT, Cavities 1 & 2 REPAIR KIT, Cavity 3	P59301-0011 (Obs.)

BASIC KITS

Repair Kit, Common Parts	R431003228
Repair Kit, Detent	R431003227
Repair Kit, Cavities 1 & 2	R431003226
Repair, Kit, Handle	R431003981
Repair, Kit, Major Cavity 3, Graduated	R431003231
Repair, Kit, Major Cavity 3, 3-Way	R431003230
Repair, Kit, Minor Cavity 3, Graduated	R431003229
Repair, Kit, Minor Cavity 3, 3-Way	R431003743

These repair kits renew the elastomer seals and some common wear parts of the components. On damaged or severely worn valves additional parts may be required. For additional parts, information and service instructions, refer to Service Bulletin SM-800.40 (available on request.)

AVENTICS Flexair[®] Valve

PART NUMBER INDEX

These repair kits renew the elastomer seals and some common wear parts of the component. On damaged or severely worn valves, additional parts may be required.

Complete part numbers of most Flexair[®] Valves in service are listed numerically in the following index. For part numbers not listed, consult the factory.

Major repair kits, which include necessary conversion kits, if applicable, are listed beside the complete part number of each valve. When these kits are installed as recommended, the result is a fully rebuilt, current Flexair Valve. If partial repairs are desired, see "Repair and Conversion Kits" page 16 for selection.

OLD PART NUMBER/MODEL CODE

NOTE: Obsolete part numbers are noted "Obs." – for service parts only – cannot be purchased. The construction of each valve is indicated by the model designation (see "Model Designation Code"). Additional information on each valve is indicated by the suffix of the complete ptn as follows:

SUFFIX:

0000 Standard valve with a current valve unit cavity 3, if filled.

The pressure range on standard valve may range from zero to any maximum delivery pressure with the design limitations of the valve. On the nameplate of a standard valve, the 4-digit suffix (replacing the 4 zeroes) of the complete part number indicates the maximum delivery pressure in psi of the graduated valve units in cavities 1 & 2. The 1st and 2nd digits apply to cavity 1, and the 3rd and 4th to cavity 2. When the digits are:

40-95 Actual maximum pressure

10-12 Multiply times 10 for actual maximum pressure

13 Maximum pressure is 135 psi. (9.3 bar)

1 digit or none Non-standard valve with obsolete details in cavity 3, if filled (a few exceptions appear, but the major repair kits listed are appropriate). Pressure ranges listed in the Index are fixed and not stamped on the valve nameplate.

000 & 4th digit Non-standard valve with a current valve unit in cavity 3. Pressure ranges listed are fixed and not stamped on the valve nameplate.

Valve		Repair Kit		Remarks	
OLD P/N	NEW P/N	OLD P/N	NEW P/N	OLD P/N	NEW P/N
P -052735-04545	R431002990	P -059301-00016	R431004970		
P -052735-06060	R431002991	P -059301-00016	R431004970		
P -052735-08080	R431002992	P -059301-00016	R431004970		
P -052735-01111	R431002989	P -059301-00016	R431004970		
P -052772-04545	R431002997	P -059301-00002	R431004964		
P -052772-06060	R431002998	P -059301-00002	R431004964		
P -052772-08080	R431002999	P -059301-00002	R431004964		
P -052772-08011	—	P -059301-00002	R431004964		
P -052772-01111	R431002996	P -059301-00002	R431004964		
P -052783-04545	—	P -059301-00016	R431004970		
P -052783-06060	—	P -059301-00016	R431004970		
P -052783-08080	R431003002	P -059301-00016	R431004970		
P -052783-01111	R431003001	P -059301-00016	R431004970		
p -052784-00000	OBSOLETE				
P -052785-00000	OBSOLETE			P -052785-00001	R431003003
P -052785-00001	R431003003	P -059301-00000	R431004962		
P -052786-00000	OBSOLETE	P -059301-00012	R431004966		
P -052809-04040	R431003007	P -059301-00002	R431004964		
P -052809-05050	—	P -059301-00002	R431004964		
P -052809-07070	R431003008	P -059301-00002	R431004964		
P -052809-09595	R431003009	P -059301-00002	R431004964		
P -052830-04040	R431003011	P -059301-00016	R431004970		
P -052830-05050	—	P -059301-00016	R431004970		
P -052830-07070	R431003012	P -059301-00016	R431004970		
P -052830-09595	R431003013	P -059301-00016	R431004970		

AVENTICS Flexair® Valve

Valve		Repair Kit		Remarks	
OLD P/N	NEW P/N	OLD P/N	NEW P/N	OLD P/N	NEW P/N
P -052867-00000	R431003020	P -059301-00002	R431004964	P -052867-00002	R431003021
P -052867-00001	OBSOLETE				
P -052867-00002	R431003021	P -059301-00002	R431004964		
P -052867-00003	R431003022	P -059301-00002	R431004964		
P -052868-00000	OBSOLETE			P -052868-00001	R431003023
P -052868-00001	R431003023	P -059301-00002	R431004964		
P -052948-00000	OBSOLETE	P -059301-00016	R431004970		
P -053082-04040	—	P -059301-00017	R431004971		
P -053082-05050	R431003097	P -059301-00017	R431004971		
P -053082-07070	—	P -059301-00017	R431004971		
P -053082-09595	—	P -059301-00017	R431004971		
P -053087-00000	OBSOLETE	P -059301-00002	R431004964	P -052772-00000	—
P -053127-05050	R431003110	P -059301-00002	R431004964		
P -053127-06565	R431003111	P -059301-00002	R431004964		
P -053127-09090	R431003112	P -059301-00002	R431004964		
P -053127-01212	R431003109	P -059301-00002	R431004964		
P -053266-00000	OBSOLETE	P -059301-00017	R431004971		
P -053268-04040	—	P -059301-00017	R431004971		
P -053268-05050	—	P -059301-00017	R431004971		
P -053268-07070	R431003146	P -059301-00017	R431004971		
P -053268-09595	R431003147	P -059301-00017	R431004971		
P -053485-04040	—	P -059301-00003	R431004965		
P -053485-05050	R431003239	P -059301-00003	R431004965		
P -053485-07070	—	P -059301-00003	R431004965		
P -053485-09595	R431003240	P -059301-00003	R431004965		
P -053488-00000	OBSOLETE	P -059301-00001	R431004963		
P -053791-00050	R431003250	P -059301-00000	R431004962		
P -053791-00065	—	P -059301-00000	R431004962		
P -053791-00090	R431003251	P -059301-00000	R431004962		
P -053791-00012	R431003249	P -059301-00000	R431004962		
P -054089-00000	OBSOLETE	P -059301-00012	R431004966	P -054173-00009	—
P -054092-05050	—	P -059301-00017			
P -054092-06565	—	P -059301-00017	R431004971		
P -054092-09090	R431003304	P -059301-00017	R431004971		
P -054092-01212	—	P -059301-00017	R431004971		
P -054157-05050	R431003308	P -059301-00002	R431004964		
P -054157-06565	R431003309	P -059301-00002	R431004964		
P -054157-09090	R431003310	P -059301-00002	R431004964		
P -054157-01212	R431003307	P -059301-00002	R431004964		
P -054177-00000	OBSOLETE	P -059301-00001	R431004963	P -054589-00001	—
P -054589-00000	OBSOLETE				
P -054589-00001	OBSOLETE	P -059301-00002	R431004964		
P -054589-00002	R431003388	P -059301-00003	R431004965		
P -054649-05555	—	P -059301-00002	R431004964		
P -054649-07575	—	P -059301-00002	R431004964		
P -054649-01010	R431003410	P -059301-00002	R431004964		
P -054649-01313	R431003411	P -059301-00002	R431004964		
P -054656-00000	R431003415	P -059301-00002	R431004964		
P -054657-05050	R431003417	P -059301-00003	R431004965		
P -054657-06565	R431003418	P -059301-00003	R431004965		
P -054657-09090	R431003419	P -059301-00003	R431004965		
P -054657-01212	R431003416	P -059301-00003	R431004965		

AVENTICS Flexair[®] Valve

Valve		Repair Kit		Remarks	
OLD P/N	NEW P/N	OLD P/N	NEW P/N	OLD P/N	NEW P/N
P -054658-00050	---	P -059301-00001	R431004963		
P -054658-00065	---	P -059301-00001	R431004963		
P -054658-00090	R431003422	P -059301-00001	R431004963		
P -054658-00012	R431003420	P -059301-00001	R431004963		
P -054699-00000	OBSOLETE	P -059301-00002	R431004964		
P -054700-00000	OBSOLETE	P -059301-00016	R431004970		
P -054701-00000	OBSOLETE	P -059301-00001	R431004963		
P -054707-00000	R431003446	P -059301-00002	R431004964		
P -054725-04040	---	P -059301-00002	R431004964		
P -054725-05050	---	P -059301-00002	R431004964		
P -054725-07070	R431003447	P -059301-00002	R431004964		
P -054725-09595	R431003448	P -059301-00002	R431004964		
P -054726-00050	---	P -059301-00013	R431004967		
P -054726-00065	---	P -059301-00013	R431004967		
P -054726-00090	---	P -059301-00013	R431004967		
P -054726-00012	---	P -059301-00013	R431004967		
P -054727-00040	---	P -059301-00013	R431004967		
P -054727-00050	---	P -059301-00013	R431004967		
P -054727-00070	---	P -059301-00013	R431004967		
P -054727-00095	---	P -059301-00013	R431004967		
P -054728-04040	---	P -059301-00013	R431004967		
P -054728-05050	---	P -059301-00017	R431004971		
P -054728-07070	---	P -059301-00017	R431004971		
P -054728-09595	R431003449	P -059301-00017	R431004971		
P -054729-00000	OBSOLETE	P -059301-00016	R431004970		
P -054730-00000	OBSOLETE	P -059301-00016	R431004970		
P -054731-00000	OBSOLETE	P -059301-00016	R431004970		
P -054732-00000	OBSOLETE	P -059301-00017	R431004971		
P -054733-00000	OBSOLETE	P -059301-00016	R431004970		
P -054734-00000	OBSOLETE	P -059301-00017	R431004971		
P -054735-00000	OBSOLETE	P -059301-00017	R431004971		
P -054736-00050	R431003450	P -059301-00000	R431004962		
P -054736-00065	R431003451	P -059301-00000	R431004962		
P -054736-00090	R431003452	P -059301-00000	R431004962		
P -054736-00012	---	P -059301-00000	R431004962		
P -054737-05050	---	P -059301-00002	R431004964		
P -054737-06565	R431009109	P -059301-00002	R431004964		
P -054737-09090	---	P -059301-00002	R431004964		
P -054737-01212	---	P -059301-00002	R431004964		
P -054738-04040	---	P -059301-00002	R431004964		
P -054738-05050	---	P -059301-00002	R431004964		
P -054738-07070	---	P -059301-00002	R431004964		
P -054738-09595	---	P -059301-00002	R431004964		
P -054766-00000	R431003454	P -059301-00002	R431004964	P -054656-00000	R431003415
P -054770-00000	---	P -059301-00000	R431004962		
P -054775-00001	OBSOLETE	P -059301-00016	R431004970		
P -054775-00002	R431003455	P -059301-00016	R431004970		
P -054776-00000	---	P -059301-00017	R431004971		
P -054776-00002	R431003456	P -059301-00017	R431004971		
P -054777-00000	OBSOLETE	P -059301-00017	R431004971		
P -054777-00001	OBSOLETE	P -059301-00017	R431004971		
P -054777-00002	---	P -059301-00017	R431004971		
P -054785-00040	---	P -059301-00000	R431004962		

AVENTICS Flexair® Valve

Valve		Repair Kit		Remarks	
OLD P/N	NEW P/N	OLD P/N	NEW P/N	OLD P/N	NEW P/N
P -054785-00050	—	P -059301-00000	R431004962		
P -054785-00070	R431003457	P -059301-00000	R431004962		
P -054785-00095	R431003458	P -059301-00000	R431004962		
P -054790-00045	—	P -059301-00000	R431004962		
P -054790-00060	R431003460	P -059301-00000	R431004962		
P -054790-00080	R431003461	P -059301-00000	R431004962		
P -054790-00011	R431003459	P -059301-00000	R431004962		
P -054830-00000	R431003464	P -059301-00002	R431004964		
P -054831-00000	R431003465	P -059301-00000	R431004962		
P -054868-00000	OBSOLETE	P -059301-00017	R431004971	P -054868-00001	R431003466
P -054868-00001	R431003466	P -059301-00017	R431004971		
P -054872-00000	OBSOLETE	P -059301-00012	R431004966		
P -055082-00000	OBSOLETE	P -059301-00002	R431004964		
P -055082-00001	OBSOLETE	P -059301-00002	R431004964	P -052809-00000	—
P -055083-00000	OBSOLETE	P -059301-00017	R431004971		
P -055264-00000	R431003685	P -059301-00002	R431004964		
P -055309-00000	OBSOLETE	P -059301-00000	R431004962		
P -055311-00000	R431003687	P -059301-00002	R431004964		
P -055323-04545	R431003689	P -059301-00017	R431004971		
P -055323-06060	R431003690	P -059301-00017	R431004971		
P -055323-08080	R431003691	P -059301-00017	R431004971		
P -055323-01111	R431003688	P -059301-00017	R431004971		
P -055415-00000	OBSOLETE	P -059301-00012	R431004966		
P -055416-00040	—	P -059301-00001	R431004963		
P -055416-00050	—	P -059301-00001	R431004963		
P -055416-00070	—	P -059301-00001	R431004963		
P -055416-00095	R431003721	P -059301-00001	R431004963		
P -055435-04040	—	P -059301-00017	R431004971		
P -055435-05050	—	P -059301-00017	R431004971		
P -055435-07070	R431003725	P -059301-00017	R431004971		
P -055435-09595	R431003726	P -059301-00017	R431004971		
P -055436-04040	—	P -059301-00017	R431004971		
P -055436-05050	—	P -059301-00017	R431004971		
P -055436-07070	R431003727	P -059301-00017	R431004971		
P -055436-09595	R431003728	P -059301-00017	R431004971	P -055459-00001	—
P -055459-00000	OBSOLETE	P -059301-00015	R431004969		
P -055459-00001	OBSOLETE	P -059301-00015	R431004969	P -055480-00001	R431003748
P -055480-00000	OBSOLETE	P -059301-00014	R431004968	P -055478-00000	R431003747
P -055480-00001	R431003748	P -059301-00014	R431004968		
P -055494-04545	R431003758	P -059301-00003	R431004965		
P -055494-06060	R431003759	P -059301-00003	R431004965		
P -055494-08080	R431003760	P -059301-00003	R431004965		
P -055494-01111	R431003757	P -059301-00003	R431004965		
P -055601-00000	—	P -059301-00017	R431004971		
P -055601-00001	R431003856	P -059301-00017	R431004971		
P -055602-00000	OBSOLETE	P -059301-00002	R431004964		
P -055603-00000	OBSOLETE	P -059301-00013	R431004967		
P -055603-00001	R431003857	P -059301-00013	R431004967	P -055603-00001	R431003857
P -055604-00001	R431003858	P -059301-00016	R431004970		
P -055613-00001	R431003859	P -059301-00013	R431004967		
P -055613-00002	—	P -059301-00013	R431004967		
P -055631-00001	R431003862	P -059301-00017	R431004971		
P -055631-00002	R431003863	P -059301-00017	R431004971		

AVENTICS Flexair[®] Valve

Valve		Repair Kit		Remarks	
OLD P/N	NEW P/N	OLD P/N	NEW P/N	OLD P/N	NEW P/N
P -055929-00000	OBSOLETE	P -059301-00017	R431004971		
P -055929-00001	OBSOLETE	P -059301-00017	R431004971		
P -055943-00000	OBSOLETE	P -059301-00002	R431004964	P -055943-00002	R431003939
P -055943-00001	OBSOLETE	P -059301-00002	R431004964	P -055943-00002	R431003939
P -055943-00002	R431003939	P -059301-00002	R431004964		
P -055944-00000	OBSOLETE	P -059301-00016	R431004970		
P -055964-00000	OBSOLETE	P -059301-00003	R431004965		
P -056171-00040	R431003962	P -059301-00000	R431004962		
P -056171-00050	—	P -059301-00000	R431004962		
P -056171-00070	—	P -059301-00000	R431004962		
P -056171-00095	R431003963	P -059301-00000	R431004962		
P -056191-00000	OBSOLETE	P -059301-00018	R431004972		
P -056249-04040	—	P -059301-00018	R431004972		
P -056249-05050	—	P -059301-00018	R431004972		
P -056249-07070	—	P -059301-00018	R431004972		
P -056249-09595	—	P -059301-00018	R431004972		
P -056278-00000	OBSOLETE	P -059301-00018	R431004972		
P -056315-00000	OBSOLETE	P -059301-00019	R431004973		
P -056425-04040	R431003966	P -059301-00016	R431004970		
P -056425-05050	—	P -059301-00016	R431004970		
P -056425-07070	—	P -059301-00016	R431004970		
P -056425-09595	—	P -059301-00016	R431004970		
P -057000-00000	OBSOLETE	P -059301-00003	R431004965		
P -057004-00000	OBSOLETE	P -059301-00019	R431004973		
P -057011-00000	OBSOLETE	P -059301-00000	R431004962		
P -057042-00000	OBSOLETE	P -059301-00017	R431004971		
P -057046-00000	OBSOLETE	P -059301-00000	R431004962		
P -057051-00000	OBSOLETE	P -059301-00017	R431004971		
P -057055-00000	OBSOLETE	P -059301-00015	R431004969		
P -057101-00000	OBSOLETE	P -059301-00012	R431004966	P -057101-00001	—
P -057101-00001	—	P -059301-00012	R431004966	P -053147-00000	R431003122
P -057116-00000	OBSOLETE	P -059301-00002	R431004964		
P -057142-00000	OBSOLETE	P -059301-00003	R431004965		
P -057143-00000	OBSOLETE	P -059301-00001	R431004963		
P -057154-00000	OBSOLETE	P -059301-00019	R431004973		
P -057158-00000	OBSOLETE	P -059301-00013	R431004967	P -057158-00002	—
P -057158-00001	OBSOLETE	P -059301-00013	R431004967	P -057158-00002	—
P -057158-00002	—	P -059301-00013	R431004967		
P -057160-00000	OBSOLETE	P -059301-00017	R431004971	P -057160-00001	R431004012
P -057160-00001	R431004012	P -059301-00017	R431004971		
P -057175-00000	OBSOLETE	P -059301-00018	R431004972	P -053153-00000	R431003128
P -057177-00000	OBSOLETE	P -059301-00013	R431004967		
P -057178-00000	OBSOLETE	P -059301-00013	R431004967		
P -057248-04040	OBSOLETE	P -059301-00016	R431004970		
P -057249-00000	OBSOLETE	P -059301-00003	R431004965		
P -057260-00000	OBSOLETE	P -059301-00016	R431004970		
P -057475-00000	OBSOLETE	P -059301-00002	R431004964		
P -057478-00000	OBSOLETE	P -059301-00015	R431004969		
P -057485-00000	OBSOLETE	P -059301-00013	R431004967		

AVENTICS Flexair® Valve

Valve		Repair Kit		Remarks	
OLD P/N	NEW P/N	OLD P/N	NEW P/N	OLD P/N	NEW P/N
P -055631-00003	R431003864	P -059301-00017	R431004971		
P -055636-00001	R431003866	P -059301-00017	R431004971	P -055435-00000	—
P -055660-00000	R431003869	P -059301-00002	R431004964		
P -055684-00000	OBSOLETE	P -059301-00016	R431004970	P -054113-00014	—
P -055693-04545	R431003898	P -059301-00002	R431004964		
P -055693-06060	R431003899	P -059301-00002	R431004964		
P -055693-08080	R431003900	P -059301-00002	R431004964		
P -055693-01111	R431003897	P -059301-00002	R431004964		
P -055694-04545	R431003901	P -059301-00016	R431004970		
P -055694-06060	—	P -059301-00016	R431004970		
P -055694-08080	R431003902	P -059301-00016	R431004970		
P -055694-01111	R431009012	P -059301-00016	R431004970		
P -055695-04545	R431003904	P -059301-00016	R431004970		
P -055695-04545	R431003904	P -059301-00016	R431004970		
P -055695-06060	—	P -059301-00016	R431004970		
P -055695-08080	R431003905	P -059301-00016	R431004970		
P -055695-01111	R431003903	P -059301-00016	R431004970		
P -055718-00000	OBSOLETE	P -059301-00002	R431004964		
P -055718-00001	OBSOLETE	P -059301-00002	R431004964		
P -055718-00002	R431003912	P -059301-00002	R431004964		
P -055718-00003	OBSOLETE	P -059301-00002	R431004964		
P -055724-00000	OBSOLETE	P -059301-00002	R431004964		
P -055724-00001	OBSOLETE	P -059301-00002	R431004964		
P -055724-00002	OBSOLETE	P -059301-00002	R431004964		
P -055725-00000	OBSOLETE	P -059301-00016	R431004970		
P -055725-00001	OBSOLETE	P -059301-00016	R431004970		
P -055725-00003	OBSOLETE	P -059301-00016	R431004970		
P -055764-00000	OBSOLETE	P -059301-00017	R431004971		
P -055765-00000	OBSOLETE	P -059301-00002	R431004964		
P -055766-00000	OBSOLETE	P -059301-00000	R431004962		
P -055784-00000	OBSOLETE	P -059301-00017	R431004971		
P -055784-00001	OBSOLETE	P -059301-00017	R431004971		
P -055784-00002	OBSOLETE	P -059301-00017	R431004971		
P -055794-00000	OBSOLETE	P -059301-00017	R431004971		
P -055794-00001	OBSOLETE	P -059301-00017	R431004971		
P -055801-00000	R431003920	P -059301-00002	R431004964		
P -055807-00000	OBSOLETE	P -059301-00012	R431004966		
P -055808-00000	OBSOLETE	P -059301-00016	R431004970		
P -055809-00000	OBSOLETE	P -059301-00002	R431004964		
P -055816-00000	OBSOLETE	P -059301-00017	R431004971		
P -055816-00002	OBSOLETE	P -059301-00017	R431004971		
P -055816-00003	OBSOLETE	P -059301-00017	R431004971		
P -055817-00000	R431003923	P -059301-00003	R431004965		
P -055845-00000	OBSOLETE	P -059301-00000	R431004962		
P -055850-00000	OBSOLETE	P -059301-00013	R431004967		
P -055855-00000	OBSOLETE	P -059301-00014	R431004968		
P -055856-00000	OBSOLETE	P -059301-00002	R431004964		
P -055871-00000	OBSOLETE	P -059301-00003	R431004965		
P -055911-00000	OBSOLETE	P -059301-00019	R431004973		

AVENTICS Flexair[®] Valve

Valve		Repair Kit		Remarks	
OLD P/N	NEW P/N	OLD P/N	NEW P/N	OLD P/N	NEW P/N
P -057526-00000	OBSOLETE	P -059301-00017	R431004971	P -058489-00001	R431004547
P -057548-00000	OBSOLETE	P -059301-00013	R431004967		
P -057594-00000	OBSOLETE	P -059301-00001	R431004963		
P -057597-00000	OBSOLETE	P -059301-00014	R431004968	P -057597-00001	R431004183
P -057597-00001	R431004183	P -059301-00014	R431004968		
P -058388-00000	OBSOLETE	P -059301-00000	R431004962		
P -058440-00000	OBSOLETE	P -059301-00019	R431004973		
P -058489-00000	OBSOLETE	P -059301-00013			
P -058489-00001	R431004547	P -059301-00017	R431004971	P -058489-00001	R431004547
P -058543-00000	R431004604	P -059301-00002	R431004964		
P -058544-00000	OBSOLETE	P -059301-00000	R431004962		
P -058545-00000	OBSOLETE	P -059301-00002	R431004964		
P -058550-00000	OBSOLETE	P -059301-00000	R431004962		
P -058626-00000	OBSOLETE	P -059301-00015	R431004969		
P -058631-00000	OBSOLETE	P -059301-00002	R431004964		
P -058631-00001	—	P -059301-00002	R431004964		
P -058899-00000	OBSOLETE	P -059301-00019	R431004973		
P -058904-00000	OBSOLETE	P -059301-00019	R431004973		
P -058925-00000	R431004815	P -059301-00017	R431004971		
P -058970-00000	OBSOLETE	P -059301-00000	R431004962		
P -058992-00001	—	P -059301-00017	R431004971		
P -059057-00001	R431004891	P -059301-00019	R431004973		
P -059057-00002	OBSOLETE	P -059301-00018	R431004972		
P -059170-00000	OBSOLETE	P -059301-00017	R431004971		
P -059175-00000	OBSOLETE	P -059301-00019	R431004973		
P -059214-00000	OBSOLETE	P -059301-00019	R431004973	P -063044-00000	—
P -059294-00050	R431004950	P -059301-00015	R431004969		
P -059294-00065	—	P -059301-00015	R431004969		
P -059294-00090	—	P -059301-00015	R431004969		
P -059294-00012	R431004949	P -059301-00015	R431004969		
p -059512-00050	—	P -059301-00012	R431004966		
p -059512-00065	—	P -059301-00012	R431004966		
p -059512-00090	—	P -059301-00012	R431004966		
p -059512-00012	—	P -059301-00012	R431004966		
P -059652-00000	OBSOLETE	P -059301-00018	R431004972		
P -059653-00000	OBSOLETE	P -059301-00019	R431004973		
P -059676-04040	—	P -059301-00018	R431004972	P -056249-04040	—
P -059676-05050	—	P -059301-00018	R431004972	P -056249-05050	—
P -059676-07070	—	P -059301-00018	R431004972	P -056249-07070	—
P -059676-09595	R431005208	P -059301-00018	R431004972	P -056249-09595	—
P -059793-00001	—	P -059301-00003	R431004965		
P -059825-00000	OBSOLETE	P -059301-00000	R431004962		
P -059836-00001	R431005264	P -059301-00016	R431004970		
P -060038-00001	OBSOLETE	P -059301-00017	R431004971		
P -060071-00000	OBSOLETE	P -059301-00016	R431004970		
P -060072-00000	OBSOLETE	P -059301-00016	R431004970		
P -060074-00000	OBSOLETE	P -059301-00003	R431004965		
P -060143-04545	R431005399	P -059301-00017	R431004971		
P -060143-06060	R431005400	P -059301-00017	R431004971		
P -060143-08080	R431005401	P -059301-00017	R431004971		
P -060143-01212	—	P -059301-00017	R431004971		
P -060314-04545	—	P -059301-00017	R431004971		

Type M Plus™ Pressure Control Valve



M-1: Foot Pedal operated for one pressure regulated circuit



M-2: Hand Lever operated for one pressure regulated circuit

FEATURES

Compact Design - Reduced size of the Type M Plus Pressure Control Valve makes it possible to group an increased number of valves in a limited area.

Sensitivity - The output pressure setting can be adjusted in increments of approximately $\frac{1}{2}$ psi (0.03 bar) with movement of the operating mechanism. When set, the outlet pressure will be maintained within plus or minus 1 psi.

Operating Ease - only light operating force is required which increases both the efficiency and output of operating personnel by decreasing operator fatigue and concentration.

Corrosion-Resistant Construction - All seals are oil-resistant synthetic rubber, and all steel parts are plated. Other parts are made of anodized aluminum or bronze - designed for even outdoor applications.

Easy Maintenance - Minimum number of moving parts and simple construction allow for easy repair.

Adjustable Handle Holding Force - Easily accessible nut on "F" suffix valves, allows for simple wrench adjustment to suit operator need.

MODELS

Type M Plus Pressure Control Valves are available in the following models:

- M-1:** FOOT PEDAL operated for one pressure regulated circuit.
- M-2:** HAND LEVER operated for one pressure regulated circuit.
- MC-2:** HAND LEVER operated for two pressure regulated circuits.
- ME-2:** HAND LEVER operated for one pressure regulated circuit and one non-regulated circuit.
- M-5:** DIRECT PUSH operated for one pressure regulated circuit.

The M-2, MC-2 and ME-2 Type M Plus Pressure Control Valves are available with the following types of lever return or holding characteristics. These characteristics are indicated by the suffix added to the designation.

NO SUFFIX - self-returning. The lever automatically returns to the "Neutral" or "Off" position when the operating force is removed.

F SUFFIX - self-holding. The lever stays in any position in which it is placed. The holding friction is adjustable.

Type M Plus™ Pressure Control Valve

DESCRIPTION

When an application dictates low cost, medium-flow capacity and accurate control of pressure, the Type M Plus Pressure Control Valve answers the need. The Type M Plus Pressure Control Valve is designed for short-distance (up to 50 feet or 15.2 meters), low-force pressure control applications. Installed with the proper positioner it replaces mechanical linkage, push-pull cable and master slave hydraulic positioning systems.

Delivery pressure is controlled by the position of the operating lever or pedal. Any increase or decrease in the system pressure is automatically compensated for by the valve once the desired output pressure is established.

STANDARD SPECIFICATIONS

Operators: Hand lever, foot pedal, and mechanical plunger.

Sensitivity: 2% of range.

Temperature Range: -40° to +160°F (-40° to +71°C)

Maximum Supply Pressure: 150 psi (10.3 bar)

Outlet Pressure: Two controllable output pressure ranges available, either 0-60 psi or 0-100 psi (0-4.2 or 0-6.9 bar)

Materials: Anodized die cast aluminum body and cover, steel handle and shaft, Buna-N-Seals, sintered iron cam shaft.

Service Manual SM-800.11 is available online at: www.aventics.com/us

CONTROL OUTPUT COMBINATIONS

The Type M Plus Pressure Control Valve is available in several combinations of graduated pressure output:

1. **Standard Pressure Graduation** - two different ranges of graduating springs are available to provide a constant rate of pressure buildup as the handle is moved toward the 60 or 100 psi (4.2 or 6.9 bar) maximum pressure position.
2. **Full Pressure Setting** - An adjustable setting can be made available on all graduating valves to provide full inlet pressure to the outlet line at predetermined positions (near the end) of the handle travel.
3. **Non-retained preload** - Graduating valves may have a non-retained preload to give a predetermined pressure in the outlet line at the beginning of handle travel.
4. **Retained preload** - This pressure maintains a predetermined pressure in the outlet line with the handle in the off position.

ADJUSTMENT

The outlet pressure of the Type M Plus Pressure Control Valve can be changed by an external adjustment. Changing the pressure for one position changes the pressure for all positions since the pressure range is fixed by the control spring characteristics.

With the operator in minimum pressure position, the valve is adjusted to vent outlet pressure to the atmosphere. When used with throttles or similar devices the valve is set to provide a preset low pressure (non-retained preload) in the circuit when the operator is moved just out of "off" position. This adjustment gives quicker response at the start of the operator movement.

REPAIR KITS:
R431000679 (P -026784-00000) - NEW Type "M" PLUS™ - includes supply valve spring, O-rings & grease tube.
R431005822 (P-061666-00000) - obsolete Type M Pressure Control - includes supply valve assembly, exhaust valve spring, O-rings & grease tube.

CONTROL OUTPUTS

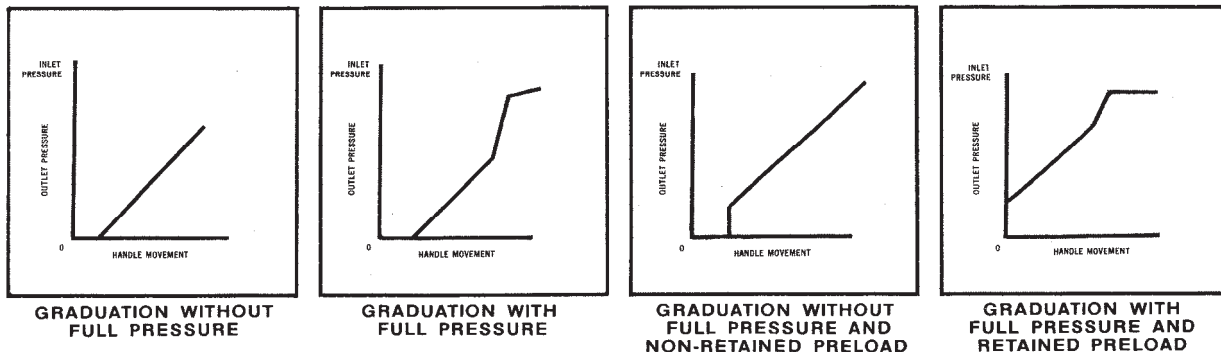

Other combinations of the above outputs can also be made available.

M-1 Pressure Control Valve

The M-1 Valve is a pedal-actuated 3 way pressure regulating valve that is designed for installations where the operator is seated. Depressing the pedal increases the outlet pressure; releasing the pedal decreases outlet pressure. The pedal is self-returning. Adjustable stops are provided to control initial pressure and final pressure over the range of pedal travel.

This valve is suitable for throttle, brake or clutch control, or wherever foot operation of pressure control is desired.

PIPE CONNECTIONS

“P” port - supply
 “A” port - delivers graduated pressure in direct proportion to pedal depression.

MODELS

0-60 psi (0 to 4.1 bar) with pedal tread part no. R431000662 (P -026716-00001)
 0-100 psi (0 to 6.9 bar) with pedal tread part no. R431000663 (P -026716-00002)

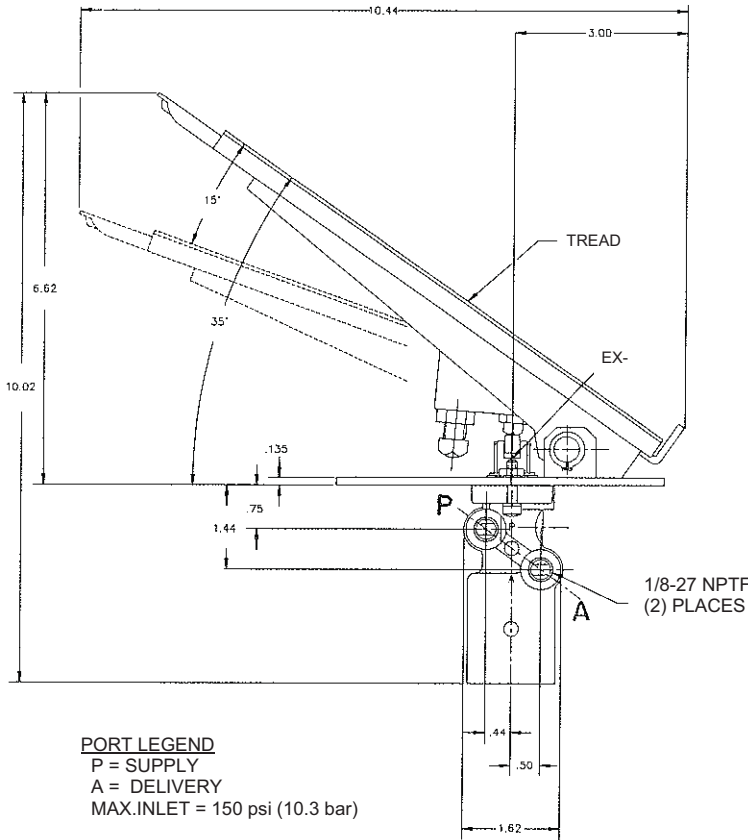

PORT LEGEND
 P = SUPPLY
 A = DELIVERY
 MAX. INLET = 150 psi (10.3 bar)

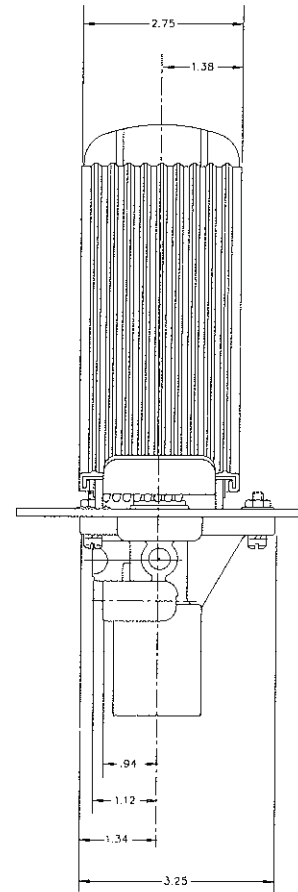

0.34 DIA. THRU (3) PL'S
 EQUALLY SPACED ON
 A 4.50 DIA. B.C.

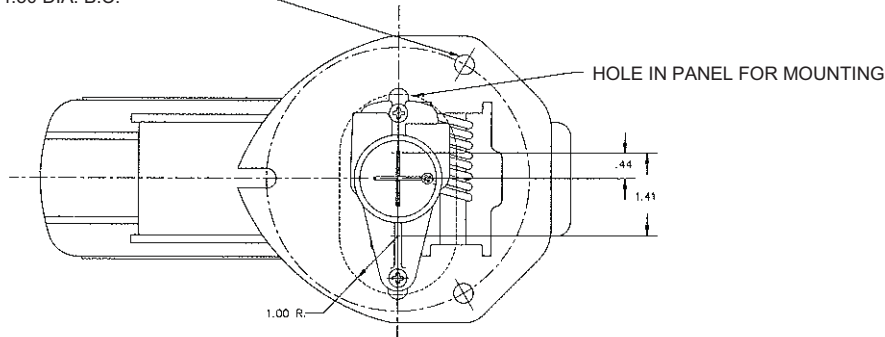

M-2 Pressure Control Valve

The M-2 Valve is a lever-operated, 3-way pressure regulating valve. Output pressure is increased, decreased or maintained at the out port according to lever position. Facing the lever side of the valve, clockwise lever movement increases pressure. Outlet pressure is maintained for the position in which the lever remains.

For throttle control applications, the valve is set with a non-retained preload of 10 psi (0.69 bar) and has a 10-60 psi (0.69 to 4.1 bar) delivery pressure range.

PIPE CONNECTIONS 1/8" NPTF

“P” port supply
 “A” port delivers graduated pressure in direct proportion to clockwise lever travel from minimum pressure position (facing lever side of valve).

MODELS

- M-2** Lever returns to minimum pressure position when released
 0-60 psi (0-4.1 bar) part no. R431000656 (P -026714-00001)
 0-100 psi (0-6.9 bar) part no. R431000657 (P -026714-00002)
 0-125 psi (0-8.6 bar) part no. R434003201 (P -026714-00003)
- M-2-F** Lever remains in position where released
 0-60 psi (0-4.1 bar) part no. R431000659 (P -026715-00001)
 0-100 psi (0-6.9 bar) part no. R431000660 (P -026715-00002)
 0-125 psi (0-8.6 bar) part no. R434003192 (P -026715-00003)
 10-60 psi (0.69 - 4.1 bar) p. n. R431000661 (P -026715-00011)

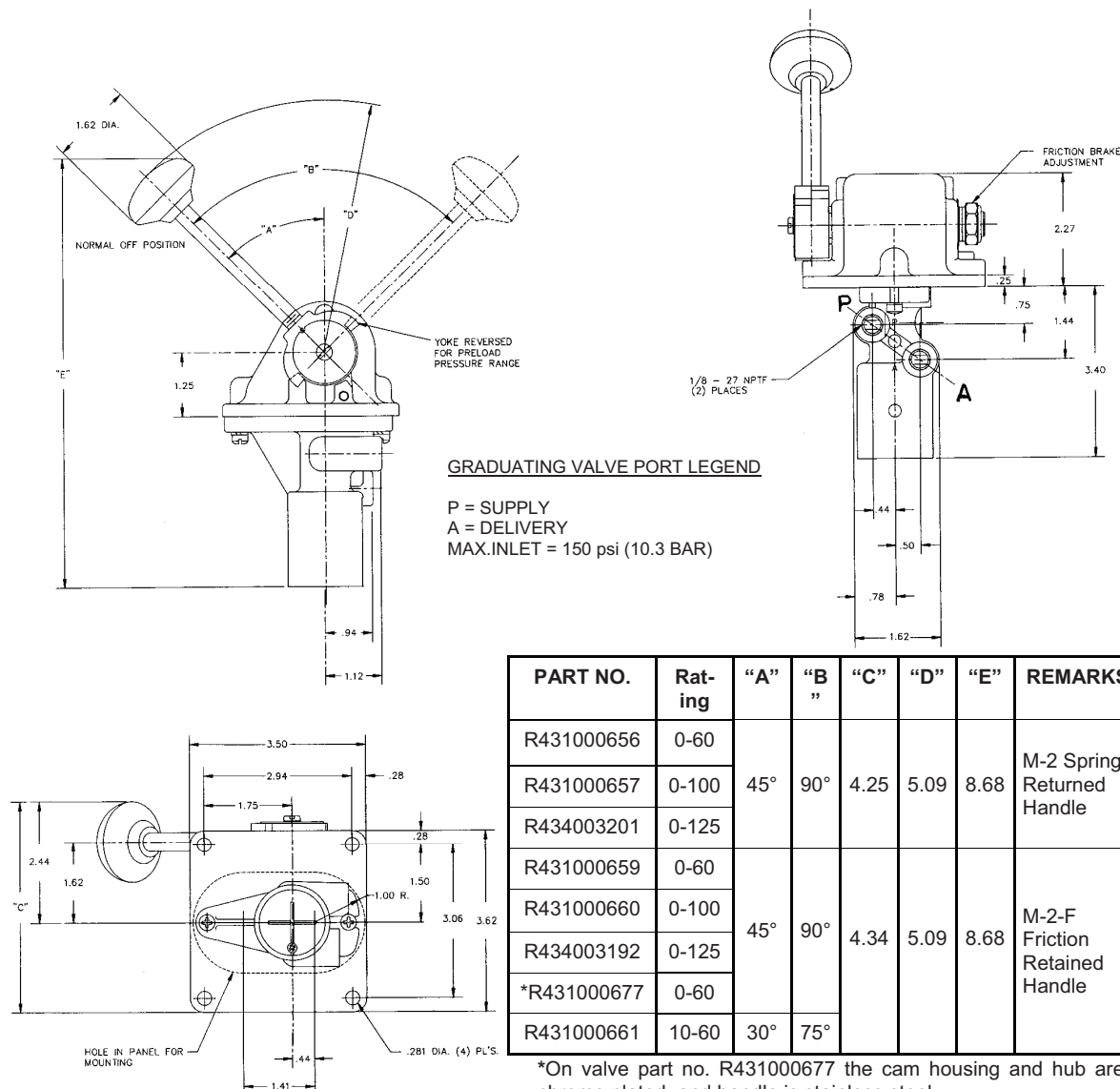

PART NO.	Rating	“A”	“B”	“C”	“D”	“E”	REMARKS
R431000656	0-60						M-2 Spring Returned Handle
R431000657	0-100	45°	90°	4.25	5.09	8.68	
R434003201	0-125						
R431000659	0-60						M-2-F Friction Retained Handle
R431000660	0-100	45°	90°	4.34	5.09	8.68	
R434003192	0-125						
*R431000677	0-60						
R431000661	10-60	30°	75°				

*On valve part no. R431000677 the cam housing and hub are chrome plated, and handle is stainless steel.

M-5 Pressure Control Valve

The M-5 Valve is a mechanically operated 3-way pressure regulating valve which can be operated by direct push, or by a cam or similar mechanical device. Total movement is approximately 1/4" (6.35 mm) with the initial 1/16" (1.6 mm) travel used to close its exhaust.

for the other models. Service Manual SM-800.11 is available online at: www.aventics.com/us

MODELS

0-60 psi (0-4.1 bar) part no. R431000666
(P -026718-00001)

0-100 psi (0-6.9 bar) part no. R431000667
(P -026718-00002)

The M-5 Valve can be used as a replacement kit

PORT LEGEND

P = SUPPLY
A = DELIVERY
MAX. INLET = 150 psi (10.3 bar)

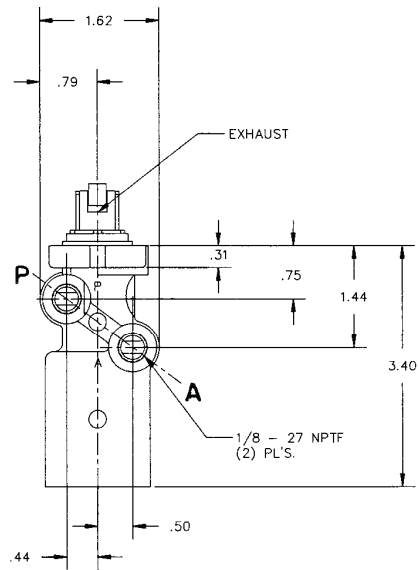
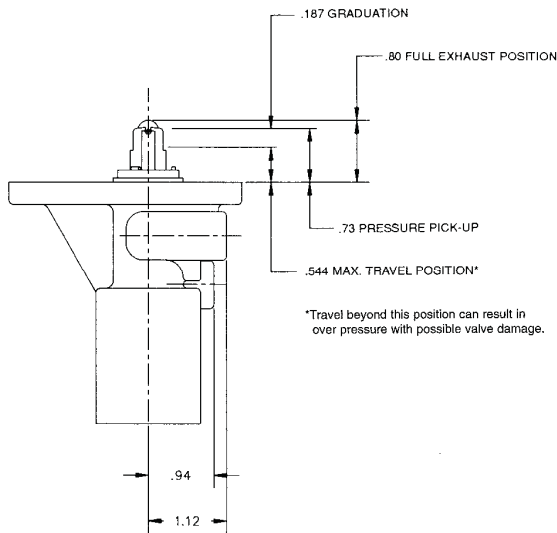
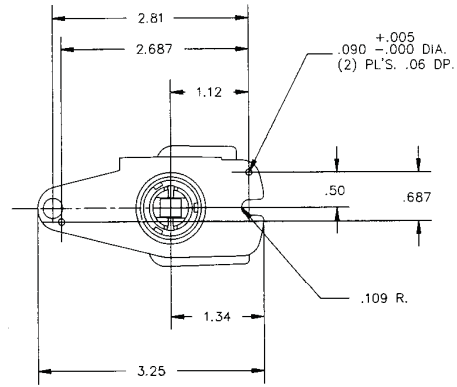

MC-2 Pressure Control Valve

The MC-2 Valve is a lever-operated, pressure regulating valve with handle normally in the center and operated toward either extremes. It consists of two 3-way pressure regulating portions. The regulating portions furnish air out of the respective delivery ports. This valve is ideal for use with spring centered positioners. Initial lever movement from "off" position, activates one of the out ports. Further movement in that direction controls the outlet pressure. The opposite out port remains connected to atmosphere.

PIPE CONNECTIONS 1/8" NPTF

- "AR" port out, graduating pressure when lever moved clockwise from "off" (facing lever side of valve)
- "P" port in pressure
- "L" port out, graduating pressure when lever is moved counterclockwise from "off"

MODELS

MC-2 Lever automatically returns to "off" position when released.

0-60 psi (0-4.1 bar) part no. R431000670 (P -026720-00001)

0-100 psi (0-6.9 bar) part no. R431000671 (P -026720-00002)

MC-2-F Lever remains in position where released. Holding friction is adjustable.

0-60 psi (0-4.1 bar) p.n. R431000668 (P -026719-00001)

0-100 psi (0-6.9 bar) p.n. R431000669 (P -026719-00002)

Part No.	Rating	Remarks
R431000670 R431000671	0-60 psi 0-100 psi	MC-2 Spring Returned To Center Handle
R431000668 R431000669	0-60 psi 0-100 psi	MC-2-F Friction Retained Handle

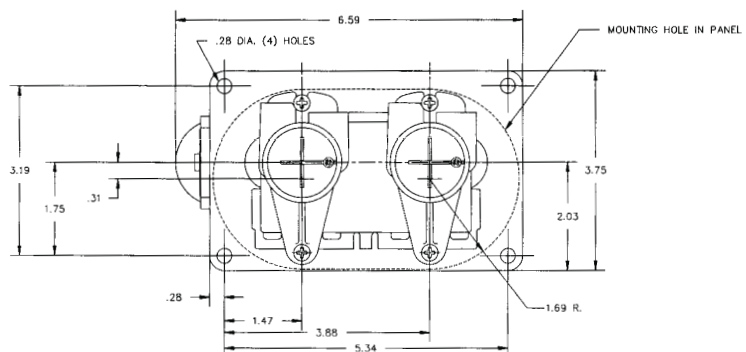
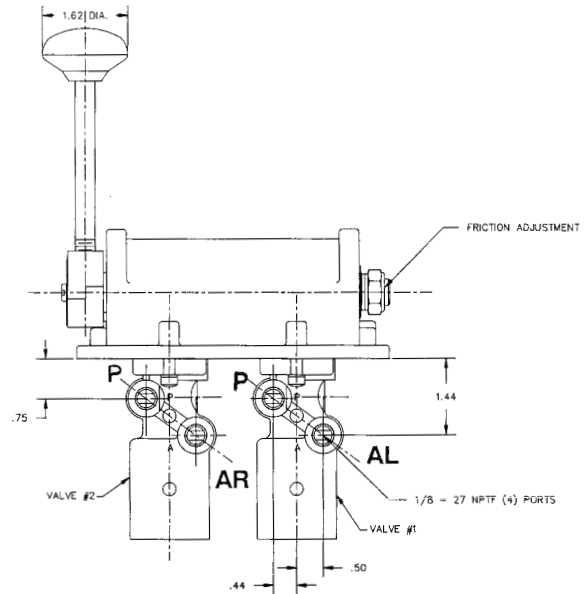
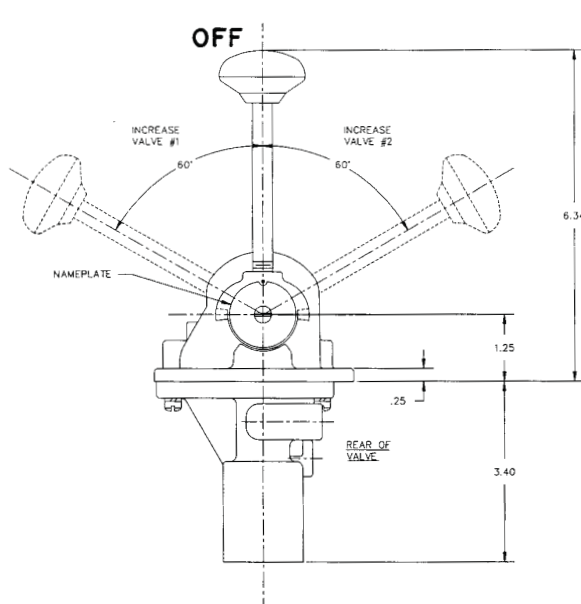

GRADUATING VALVE PORT LEG-
END

P = SUPPLY
A = DELIVERY

ME-2 Pressure Control Valve

The ME-2 Valve is a composite lever operated directional valve consisting of a 3-way directional valve and a 3-way pressure regulating valve, each unit having its own out port. The first 45° of lever travel from “off”, opens the directional valve to provide full inlet pressure for its out port. Further travel controls the air pressure delivered by the pressure regulating portion. The graduated pressure varies directly with lever travel. The valves are used for clutch, brake and other similar applications.

Pipe Connections 1/8" NPTF graduating valve
1/4" NPTF on-off valve

“Out” port #2 (on-off valve) -- full inlet pressure when lever is moved 45° clockwise from “off” (facing lever side of valve).

“In” port (on-off valve) -- in pressure

“P” port (graduating valve) -- in pressure

“A” port (graduating valve) -- out, graduated pressure when lever is moved counter-clockwise from “off”.

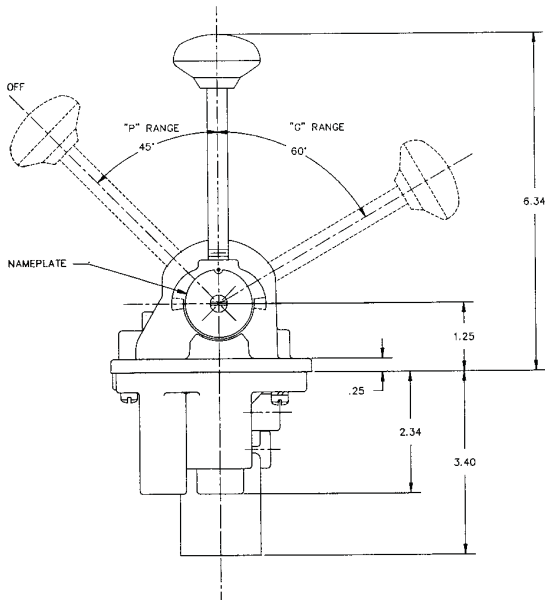

MODELS

ME-2 Lever automatically return to “off” positions when released

0-60 psi (0-4.1 bar) part no. R431009137 (P -026722-00001)

0-100 psi (0-6.9 bar) part no. R431000674 (P -026722-00002)

ME-2-F Lever remains in the position where released.

Holding friction is adjustable.

0-100 psi (0-6.9 bar) part no. R431000673 (P -026721-00002)

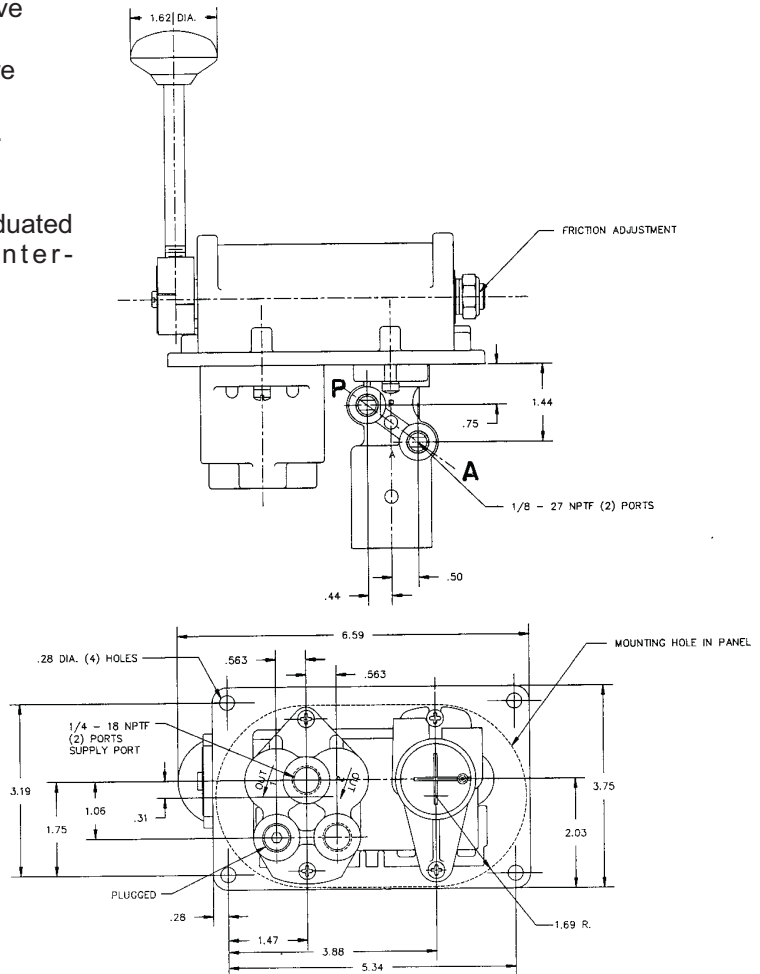

PART NO.	HANDLE POSITION	PORT - OUT 2 ON - OFF VALVE	PORT A GRAD VALVE	REMARKS
R431009137 (P -026722-00001)	“G” Range	Supply	0-60 Grad	ME-2 Spring Returned To OFF Handle
	“P” Range	Supply	Vented	
	OFF	Vented	Vented	
R431000674 (P -026722-00002)	“G” Range	Supply	0-100 Grad	
	“P” Range	Supply	Vented	
	OFF	Vented	Vented	
R431000673 (P -026721-00002)	“G” Range	Supply	0-100 Grad	ME-2-F Friction Retained Handle
	“P” Range	Supply	Vented	
	OFF	Vented	Vented	

TYPE M PLUS™ PRESSURE CONTROL VALVE
Cross Reference/Identity Schedule

DESIGNATION	OBSOLETE "M" VALVES	NEW M PLUS™ VALVES	OLD M PLUS™ VALVES	OBSOLETE "M" VALVE PORTIONS	NEW TYPE M PLUS™ VALVE PORTIONS	OLD TYPE M PLUS™ VALVE PORTIONS	NEW OPERATOR PORTION	OLD OPERATOR PORTION
M-5 (0-65 psi)	P -060403-00001	R431000666	P -026718-00001	P -060394-00001	R431000634	P -026672-00001	---	---
M-5 (0-100 psi)	P -060403-00002		P -026718-00002	P -060394-00002	R431000635	P -026672-00002	---	---
M-5 (10-65 psi)	---	---	P -026718-00011	---	---	---	---	---
M-5 (Special)	---	---	P -029029-00002	---	---	---	---	---
M-1 (0-60 psi)	P -060401-00001	R431000662	P -026716-00001	P -060394-00001	R431000634	P -026672-00001	R431005527	P -060397-00001
M-1 (0-100 psi)	P -060401-00002	R431005820	P -061652-00000	P -060394-00002	R431000635	P -026672-00002	R431005527	P -060397-00001
M-1 (0-60 psi)	P -060402-00001	R431000664	P -026717-00001	P -060394-00001	R431000634	P -026672-00001	R431005526	P -060397-00000
M-1 (10-100 Psi)	P -060402-00002	R431000665	P -026717-00002	P -060394-00002	R431000635	P -026672-00002	R431005526	P -060397-00000
M-1	---	R434001418	P -029028-00001	---	---	---	---	---
M-1	---	R431000678	P -026775-00000	---	R431000626	P -062205-0000	R431005026	P -059346-0000
M-1	P -067530-00000	R431000678	P -026775-00000	P -060394-00001	R431000634	P -026672-00001	---	---
M-2 (0-60 psi)	P -061230-00001	R431000656	P -026714-00001	P -060394-00001	R431000634	P -026672-00001	R431005724	P -061241-00000
M-2 (0-100 psi)	P -061230-00002	R431000657	P -026714-00002	P -060394-00002	R431000635	P -026672-00002	R431005724	P -061241-00000
M-2 (0-125 psi)	---	R434003201	P -026714-00003	---	---	P -026672-00003	R431005724	P -061241-00000
M-2 (10-65 psi)	---	R431000658	P -026714-00011	---	R431000772	P -027222-00001	R431005724	P -061241-00000
M-2 (0-60 psi) chrome housing & hub	---	R431000805	P -027488-00001	---	R431000634	P -026672-00001	R431005726	P -061241-00002
M-2 (0-100 psi) spring return w/latch	---	R434001432	P -028103-00002	---	---	---	---	---
M-2 (0-100 psi) w/SS roller	---	R434001434	P -028817-00002	---	R431000920	P -028822-00002	R431005724	P -061241-0000
M-2 (0-100 psi) hub & handle opposite side	---	R434001855	P -031239-00002	---	R431000634	P -026672-00001	R431005728	P -061241-00004
M-2 (0-60 psi) w/SS roller	---	R434001414	P -028817-00001	---	R434001408	P -028822-00001	R431005724	P -061241-00000
M-2-F (0-60 psi)	P -060400-00001	R431000659	P -026715-00001	P -060394-00001	R431000634	P -026672-00001	R431005514	P -060395-00000
M-2-F (0-100 psi)	P -060400-00002	R431000660	P -026715-00002	P -060394-00002	R431000635	P -026672-00002	R431005514	P -060395-00000
M-2-F (0-125 psi)	---	R434003192	P -026715-00003	---	R431000636	P -026672-00004	R431005514	P -060395-00000
M-2-F (10-60 psi)	P -060400-00011	R431000661	P -026715-00011	P -060394-00001	R431000634	P -026672-00001	R431005515	P -060395-00001
M-2-F (40-90 psi)	---	R434003184	P -026715-00023	---	R431001110	P -030745-00002	R431005515	P -060395-00001
M-2-F (0-100 psi)	P -062142-00002	---	---	P -060394-00002	R431000635	P -026672-00002	---	P -062143-00000
M-2-F (0-100 psi)	P -062147-00002	R431000738	P -027161-00002	P -060394-00002	R431000635	P -026672-00002	R431005516	P -060395-00002
M-2-F (0-60 psi)	P -064905-00001	R431000675	P -026772-00001	P -060394-00001	R431000634	P -026672-00001	R431005517	P -060395-00004
M-2-F (0-100 psi)	P -064905-00002	R431000676	P -026772-00002	P -060394-00002	R431000635	P -026672-00002	R431005517	P -060395-00004
M-2-F (0-60 psi) chrome housing & hub	P -065286-00001	R431000677	P -026773-00001	P -060394-00001	R431000634	P -026672-00001	R431005518	P -060395-00005
M-2 (0-100 psi) chrome housing & hub	---	R434003194	P -026773-00002	---	R431000635	P -026672-00002	R431005518	P -060395-00005
M-2-F (0-60 psi)	---	R431000737	P -027157-00001	---	R431000634	P -026672-00001	R431005519	P -060395-00007
M-2-F (0-100 psi)	---	---	P -027797-00002	---	R431000635	P -026672-00002	R431005520	P -060395-00008
M-2-F (0-100 psi) w/ss roller	---	R434001415	P -028897-00002	---	R431000920	P -028822-00002	R431005514	P -060395-00000
M-2-F (0-60 psi) w/ss short handle	---	R434001878	P -031281-00001	---	R431000634	P -026672-00001	R431005514	P -060395-00000
MC-2 (0-60 psi)	P -061239-00001	R431000670	P -026720-00001	P -060394-00001 (2 req'd)	R431005067	P -059360-00001 (2 req'd)	R431005730	P -061243-00000
MC-2 (0-100 psi)	P -061239-00002	R431000671	P -026720-00002	P -060394-00002 (2 req'd)	R431005059	P -059358-00000 (2 req'd)	R431005730	P -061243-00000
MC-2 10-100 psi)	P -064338-00002	---	---	P -060394-00001 (2 req'd)	R431005060	P -059358-00001 (2 req'd)	R431005731	P -061243-00002
MC-2 (0-60 psi)	---	R434001428	P -027727-00002	---	R431000635	P -026672-00002	R431007480	P -069564-00000
MC-2 (0-100 psi)	---	R434001335	P -030817-00002	---	R431000635	P -026672-00002	R431001119	P -030818-00000
MC-2-F (0-60 psi)	P -061142-00001	R431000668	P -026719-00001	P -060394-00001 (2 req'd)	R431000634	P -026672-00001 (2 req'd)	R431005673	P -061132-00000
MC-2-F (0-100 psi)	P -061142-00002	R431000669	P -026719-00002	P -060394-00002 (2 req'd)	R431000635	P -026672-00002 (2 req'd)	R431005673	P -061132-00000
ME-2 (0-60 psi)	P -061953-00001	R431009137	P -026722-00001	P -060394-00001	R431000634	P -026672-00001	R431005925	P -061954-00000
ME-2 10-100 psi)	P -061953-00002	R431000674	P -026722-00002	P -060394-00002	R431000635	P -026672-00002	R431005925	P -061954-00000
ME-2-F (0-60 psi)	P -061910-00001	R431000672	P -026721-00001	P -060394-00001	R431000634	P -026672-00001	R431005910	P -061911-00000
ME-2-F (0-100 psi)	P -061910-00002	R431000673	P -026721-00002	P -060394-00002	R431000635	P -026672-00002	R431005910	P -061911-00000
ME-2-F (0-100 psi)	P -060971-00002	---	---	P -060394-00002	R431000634	P -026672-00002	R431005646	P -060972-00000

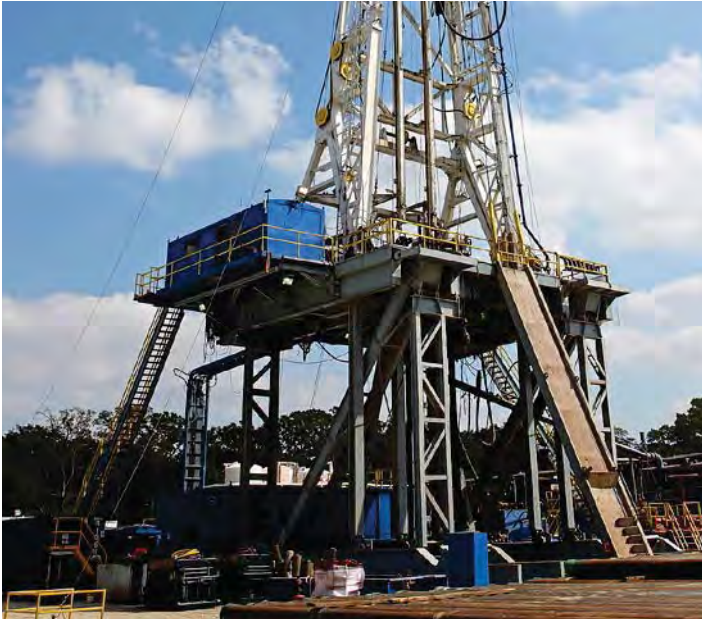

AVENTICS actuator/positioners are compact, pneumatically operated devices used for accurate positioning of diesel engine governor control arms, butterfly valves, carburetors and other low-force mechanisms. AVENTICS pneumatic actuators are the industry leader in oil/gas drilling and well servicing applications, including transmissions, positioning hydraulic valves, clutches and brakes, plus railcar hopper control and other uses common to mobile/oilfield equipment.

A-2-H actuators

These diaphragm-lever radial actuators have a power rating of 410 in-lb-degrees and come in four pressure range choices up to 90 psi. The A-2-H has a nominal stroke of 2", adjustable from 1-7/8" to 2-1/4".



AA actuators

These powerful diaphragm lever type actuators have a force rating up to 1,125 inch-lb-degrees. Single- and two-direction models are available, as well as models with a separately controlled stop cylinder. Output travel is adjustable from 7/8" to 2-1/4", with a pressure range of 0–60 psi.

Two direction positioners

These versatile linear positioners move one-half their total stroke length in each direction from a center "zero" position. They feature three total stroke lengths: 1", 1-1/2" and 2". Force ratings range from 410 to 820 in-lb-degrees, and four pressure range choices up to 115 psi are available.

"C" linear positioners

These small linear piston type positioners have integral female clevises for easy mounting. Two sizes are offered, with force ratings of 650 and 1,400 in-lb-degrees. Strokes are 1-1/5" or 3", and operating pressure ranges from 0–60 psi.



Multi-position transmission cylinders

These air cylinders are discreet positioning devices which can be controlled by "A" or "D" Pilotair® or "P" Rotair® valves depending on number of positions. Two through eight position models have various stroke lengths, available in 1/16" increments. Maximum operating pressure can be up to 250 psi depending on the model.

Construction grade (cast iron) cylinders

Constructed of unyielding semisteel, these durable cylinders are unequalled for clutch and brake applications. The cylinders feature an integral female clevis mounting. Operating pressure is 120 psi, and strokes range from 2-1/2" to 7". Single- and double-acting models, and bore sizes from 2-1/2" to 4-1/2" are offered.

Hopper dump railcar cylinders

These heavy-duty 8", 10", 12" or 14" bore air cylinders operate hopper gates. Cast ductile iron heads and caps are standard, with stroke lengths from 10" to 30". The cylinder tubing can be chrome plated I.D. steel or lightweight corrosion-resistant fiberglass. NFPA type MP1 and MS4, or customized, mounts are available.



NOTICE TO PRODUCT USERS

1. WARNING: FLUID MEDIA

AVENTICS pneumatic devices are designed and tested for use with filtered, clean, dry, chemical free air at pressures and temperatures within the specified limits of the device. For use with media other than air or for human life support systems, AVENTICS must be consulted. Hydraulic cylinders are designed for operation with filtered, clean, petroleum based hydraulic fluid; operation using fire-resistant or other special types of fluids may require special packing and seals. Consult the factory.

2. WARNING: MATERIAL COMPATIBILITY

Damage to product seals or other parts caused by the use of non-compatible lubricants, oil additives or synthetic lubricants in the air system compressor or line lubrication devices voids the AVENTICS warranty and can result in product failure or other malfunction. See lubrication recommendations below.

AIR LINE LUBRICANTS! In service higher than 18 cycles per minute or with continuous flow of air through the device, an air line lubricator is recommended.* (Do not use line lubrication with vacuum products.) However, the lubricator must be maintained since the oil will wash out the grease, and lack of lubrication will greatly shorten the life expectancy. The oils used in the lubricator must be compatible with the elastomers in the device. The elastomers are normally BUNA-N, NEOPRENE, VITON, SILICONE and HYTREL. AVENTICS recommends the use of only petroleum based oils without synthetic additives, and with an aniline point between 180° F and 210° F.

COMPRESSOR LUBRICANTS! All compressors (with the exception of special "oil free" units) pass oil mist or vapor from the internal crankcase lubricating system through to the compressed air. Since even small amounts of non-compatible lubricants can cause severe seal deterioration (which could result in component and system failure) special care should be taken in selecting compatible compressor lubricants.

3. WARNING: INSTALLATION AND MOUNTING

The user of these devices must conform to all applicable electrical, mechanical, piping and other codes in the installation, operation or repair of these devices.

INSTALLATION! Do not attempt to install, operate or repair these devices without proper training in the technique of working on pneumatic or hydraulic systems and devices, unless under trained supervision. Compressed air and hydraulic systems contain high levels of stored energy. Do not attempt to connect, disconnect or repair these products

when a system is under pressure. Always exhaust or drain the pressure from a system before performing any service work. Failure to do so can result in serious personal injury.

MOUNTING! Devices should be mounted and positioned in such a manner that they cannot be accidentally operated.

4. WARNING: APPLICATION AND USE OF PRODUCTS

The possibility does exist for any device or accessory to fail to operate properly through misuse, wear or malfunction. The user must consider these possibilities and should provide appropriate safe guards in the application or system design to prevent personal injury or property damage in the event of a malfunction.

5. WARNING: CONVERSION, MAINTENANCE AND REPAIR

When a device is disassembled for conversion to a different configuration, maintenance or repair, the device must be tested for leakage and proper operation after being reassembled and prior to installation.

MAINTENANCE AND REPAIR! Maintenance periods should be scheduled in accordance with frequency of use and working conditions. All AVENTICS products should provide a minimum of 1,000,000 cycles of maintenance free service when used and lubricated as recommended. However, these products should be visually inspected for defects and given an "in system" operating performance and leakage test once a year. Where devices require a major repair as a result of the one million cycles, one year, or routine inspection, the device must be disassembled, cleaned, inspected, parts replaced as required, rebuilt and tested for leakage and proper operation prior to installation. See individual catalogs for specific cycle life estimates.

6. PRODUCT CHANGES

Product changes including specifications, features, designs and availability are subject to change at any time without notice. For critical dimensions or specifications, contact factory.

*Many AVENTICS pneumatic valves and cylinders can operate with or without air line lubrication; see individual sales catalogs for details.

-Refer to the appropriate service manual for parts and service information, most are available for download from www.aventics.com/us/downloads

WARRANTIES

7.1 Emerson warrants that:

- Emerson will transfer title to the Goods (excluding Software and Firmware) to Customer under Clause 4 of our Terms and Conditions of Sale*;
- Goods, Documentation and Services will conform with the Specification;
- Goods made by Emerson or its Affiliates will, under normal use and care, be free from defects in materials or workmanship; and
- Emerson and its Affiliates' Personnel delivering Services are trained and will use reasonable skill and care.

7.2 Warranty Periods. Unless otherwise specified by Emerson, the warranties in Clause 7.1 apply as follows:

- Goods: until the earlier of 12 months from the first installation or 18 months from delivery (90 days from delivery in the case of consumables);
- Services: for 90 days from completion of the Services;
- Goods repaired, replacement items and Services re-performed: from delivery of the replacement or completion of the repair or re-performance, for 90 days or until the end of the original warranty period (if later).

7.3 Warranty Procedure. Clause 7.3 applies if, within the warranty period, Customer discovers any non-conformity with a warranty in Clause 7.1, tells Emerson in writing and, in the case of Goods, returns the non-conforming items at Customer's cost, freight and insurance pre-paid, to the repair facility chosen by Emerson. Where this Clause applies, Emerson will, at its sole option, either:

- correct any non-conforming Documents and Services; or
- repair or replace non-conforming Goods FCA (Incoterms® 2010) at the repair location; or
- instead refund the price of the non-conforming item.

7.4 Exclusions from Warranty.

- The warranties in Clause 7.1(b), (c) and (d) exclude and Customer will pay the cost of all repairs and replacements caused by any of the following: normal wear and use; inadequate maintenance; unsuitable power sources or environmental conditions; improper handling, storage, installation, or operation; misuse or accident caused by anybody except Emerson; a modification or repair not approved by Emerson in writing; materials or workmanship made, provided or specified by Customer; contamination; the use of unapproved parts, firmware or software; Cyber Attack; any other cause not the fault of Emerson.
- Emerson will not pay any costs relating to non-compliance with a warranty in Clause 7.1, except where agreed in writing in advance. Unless accepted in writing by Emerson, Customer will pay:
 - all costs of dismantling, freight, reinstallation and the time and expenses of Emerson Personnel for travel under Clause 7; and
 - all costs incurred by Emerson in correcting nonconformities for which Emerson is not responsible under Clause 7 and in examining items that comply with the warranties in Clause 7.1.
- If Emerson relies on wrong or incomplete information supplied by Customer, all warranties are void unless Emerson agrees otherwise in writing.
- Customer alone is responsible for the selection, maintenance and use of the Goods.
- Resale Products carry only the warranty given by the original manufacturer. Emerson has no liability for Resale Products beyond making a reasonable commercial effort to arrange procurement and shipping of the Resale Products.

7.5 Disclaimer. The limited warranties set out in this Clause 7 are the only warranties made by Emerson and can be changed only with Emerson's signed written agreement. THE WARRANTIES AND REMEDIES IN CLAUSE 7 ARE EXCLUSIVE. THERE ARE NO REPRESENTATIONS OR WARRANTIES OF ANY KIND, EXPRESS OR IMPLIED, ABOUT MERCHANTABILITY, FITNESS FOR PARTICULAR PURPOSE OR ANYTHING ELSE FOR ANY OF THE GOODS, DOCUMENTATION OR SERVICES.

*Additional conditions apply - for full details, visit our website to download our Terms and Conditions of Sale:

For U.S.: www.aventics.com/us/downloads | For Canada: www.aventics.com/ca | (AVENTICS Corporation is owned by Emerson Electric Co.)

Emerson Automation Solutions

1953 Mercer Road
Lexington, KY 40511
Tel 859.254.8031
Fax 800.489.1488
www.aventics.com/us
info.us@aventics.com



Further contacts:

www.aventics.com/en/contact

The data specified only serve to describe the product. No statements concerning a certain condition or suitability for a certain application can be derived from our information. The information given does not release the user from the obligation of own judgment and verification. It must be remembered that our products are subject to a natural process of wear and aging.