

The **C Series** is a robust compact cylinder line that is designed to fit tight space requirements. The low profile design and variety of mounting options makes this cylinder line extremely popular. Furthermore, its unique style and diversity makes the C Series a one of a kind compact cylinder line.

Tube

The **tube** is hard coat anodized aluminum. The hard coating is an electro-chemical process, which produces a very dense surface of aluminum oxide. This surface has extreme hardness (60 RC.), excellent wear and corrosion resistance, and a low coefficient of friction. Additionally, profile tubing is standard on 3/4" through 2-1/2" bore sizes (3" and 4" bores are the tie rod configuration). The profile tubing has a custom dovetail groove on all sides for trouble-free switch and accessory mounting.

End Caps

The **end caps** are accurately machined from solid aluminum bar stock. They are anodized for corrosion resistance. Additionally, a recess on the piston-mating surface (at both ends) enables the air to work on a larger piston area for effortless breakaway.

Rod Bushing

The C Series includes a sintered bronze **rod bushing** for maximum load bearing support.

Rod Seal

The quad ring **rod seal** ensures proper sealing even at low pressures.

Piston Rod

High strength steel (100,000 psi minimum yield) **piston rod** has a ground, polished, and chrome plated surface. This surface provides maximum life for both the rod bushing and the seals.

Piston Seal

The quad ring **piston seal** ensures proper sealing even at low pressures.

Piston

The solid aluminum alloy **piston** is strong and durable.

Tie Rods

The **tie rods** (3" and 4" only) are 100,000 psi minimum yield steel for maximum holding power. The threads are roll formed for superior strength and engagement.



Tube End Seal

The **tube end seals** are compression type and reusable.

Ports

Our enhanced **port** design enables the cylinder to work more efficiently. Through the use of precise machining depths and tool shape, we are able to smooth the flow path into and out of the cylinder.

Mounting Holes

The dual purpose **mounting holes** allow use of through bolts or threaded-in attachments.

Standard Specifications

- Variety of mounts
- Bore sizes from 3/4" through 4"
- Piston rod diameters from 1/4" to 1"
- Maximum pressure rating is 250 psi air
- Standard temperature -10°F to 165°F (-23°C to 74°C)
- All aluminum construction
- NPTF ports
- Flexible port locating

How to Order

Leave blank unless using MU or BK option.

P1 C L - 04 A 1 B - A AA 0 04 0

Mount

- F1 = Front Flange
- F2 = Rear Flange
- P1 = Fixed Clevis
- P2 = Detachable Clevis
- P3 = Fixed Eye
- P4 = Detachable Eye
- R3 = Round Head and Cap
- S2 = Foot Mount
- *S4 = Bottom Tapped
- X0 = Basic-No Mount
- *S4 mount is standard on 3/4" and 1 1/8" bore.

Type

- C = Compact Cylinder Line

Bore

- C = 3/4"
- G = 1-1/8"
- K = 1-1/2"
- L = 2"
- M = 2-1/2"
- N = 3"
- R = 4"

Full Inches of Stroke

- 00 = 0" Stroke
- 01 = 1" Stroke
- 02 = 2" Stroke
- 03 = 3" Stroke
- 20 = 20" Stroke

Fractional Inches of Stroke

- A = 0" I = 1/2"
- B = 1/16" J = 9/16"
- C = 1/8" K = 5/8"
- D = 3/16" L = 11/16"
- E = 1/4" M = 3/4"
- F = 5/16" N = 13/16"
- G = 3/8" O = 7/8"
- H = 7/16" P = 15/16"

Rod End Code

- *1 = #1 Standard Rod Diameter
- 2 = #2 Standard Rod Diameter
- 3 = #3 Standard Rod Diameter
- 4 = Special Standard Rod Diameter (must specify threads)
- 5 = Special Oversize Rod Diameter (must specify threads)
- 6 = #1 Oversize Rod Diameter
- 7 = #2 Oversize Rod Diameter
- 8 = #3 Oversize Rod Diameter

Fractional Inches of Stroke

- A = 0" I = 1/2"
- B = 1/16" J = 9/16"
- C = 1/8" K = 5/8"
- D = 3/16" L = 11/16"
- E = 1/4" M = 3/4"
- F = 5/16" N = 13/16"
- G = 3/8" O = 7/8"
- H = 7/16" P = 15/16"

Full Inches of Stroke

- 00 = 0" Stroke
- 01 = 1" Stroke
- 02 = 2" Stroke
- 03 = 3" Stroke

Magnet Piston

- 0 = no magnet
- *2 = Reed Magnet & Wear Band
- * Adds to OAL of cylinder, see pg.3

Options

- AA = No options
- ***BA = Bumpers Both Ends
- KA = Stroke Adjuster (Specify Length)
- DA = Double Rod End
- NA = Nickel Plated
- SA = Stainless Steel Rod
- **SE = Spring Extend
- **SR = Spring Retract
- SS = Stainless Steel Rod and Tie Rods (3 and 4 Bores)
- ST = Stainless Steel Tie Rods (3 and 4 Bores)
- VA = FKM Seals
- 1A = Rod Extension (specify length)
- *WA = Wear Band
- MU = Multiposition Cylinder
- BK = Back to Back Cylinder
- TD = Tandem Cylinder
- * Adds to OAL of cylinder, see pg.3
- **2" Stroke Maximum
- ***Bumpers add .062" to OAL (per bumper)

Cushions

- A = No Cushions

Ports

| Position# | 10-32 | *1/8" | 1/4" |
|-----------|-------|-------|------|
| 1 | A | B | C |
| 2 | G | H | I |
| 3 | M | N | O |
| 4 | S | T | U |

NOTE: 1/8" and 1/4" ports can affect OAL of cylinder.

See page 3 for details.

Cylinder Orientation

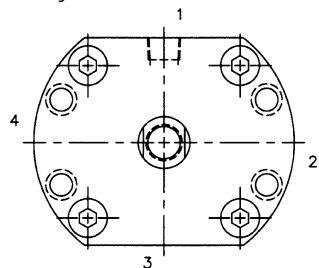

Ports Normally in Position 1

Rod End Styles, Diameters and Threads

| Bore | Diameter | Style #1 Standard Male | Style #2 Optional Female | Style #3 Standard Female |
|--------|----------|------------------------|--------------------------|--------------------------|
| 3/4" | 0.250 | #8-32 | N/A | #8-32 |
| 1 1/8" | 0.500 | 1/4-28 | 5/16-24 | 1/4-28 |
| 1 1/2" | 0.625 | 7/16-20 | 3/8-24 | 7/16-20 |
| | 0.750 | 1/2-20 | N/A | 1/2-20 |
| 2" | 0.625 | 7/16-20 | N/A | 7/16-20 |
| | 0.750 | 1/2-20 | N/A | 1/2-20 |
| 2 1/2" | 0.625 | 7/16-20 | N/A | 7/16-20 |
| | 0.750 | 1/2-20 | N/A | 1/2-20 |
| 3" | 1.000 | 3/4-16 | 5/8-18 | 3/4-16 |
| 4" | 1.000 | 3/4-16 | N/A | 3/4-16 |

*NOTE: Style #1 Male rods are studded female rods

How to Order continued

Figure 1.
Wear Band Option

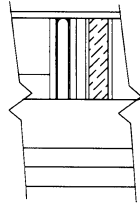

Side load and misalignment are major factors that can cause premature failure of the rod bushing and piston, the two load bearing points on a cylinder.

The Wear Band option separates the load bearing points by locating the wear band at the rear of the piston assembly, to give maximum column strength even at full extension (Fig. 1).

The wear band is a stable, lubricating strip placed far back on the piston. Its width and placement serve to locate piston load at the optimum point.

Order as "WA" Option or by putting a "2" in the magnetic piston code

Minimum Length detail for Switches

| Bore | Min. Stroke "Sense One End" | Min. Stroke "Sense Both Ends" |
|--------|-----------------------------|-------------------------------|
| 3/4" | 1/2" | 1/2" |
| 1 1/8" | 1/2" | 1/2" |
| 1 1/2" | 7/16" | 7/16" |
| 2" | 7/16" | 7/16" |
| 2 1/2" | 1/4" | 3/8" |
| 3" | 1/4" | 3/8" |
| 4" | 1/8" | 3/8" |

C Series Length Adders

Standard Adders

| Cylinders | Bore | WA Option | "2" Magnet Code | "BA" Option Bumpers (Both Ends) | 1/8" NPT Ports |
|-----------|--------|-----------|-----------------|---------------------------------|----------------|
| C-series | 0.75" | *1.05" | *1.05" | 0.125" | 0.500" |
| C-series | 1.125" | *0.925" | *0.925" | 0.125" | 0.500" |
| C-series | 1.5" | *0.937" | *0.937" | 0.125" | N/A |
| C-series | 2" | *0.937" | *0.937" | 0.125" | N/A |
| C-series | 2.5" | *1" | *1" | 0.125" | N/A |
| C-series | 3" | *0.750" | *0.750" | 0.125" | N/A |
| C-series | 4" | *0.875" | *0.875" | 0.125" | N/A |

Combo Adders

| WA(wearband)+ 2(Reed Magnet) |
|------------------------------|
| *1.05" |
| *0.925" |
| *0.937" |
| *0.937" |
| *1" |
| *0.750" |
| *0.875" |

Special Notes:

* For cylinders that require a "2" (reed) magnet, a special piston will be used. This piston will incorporate the wearband, so when the "2" style magnet is ordered the cylinder will automatically have a wearband. For cylinders that require a "WA" option (wearband) this same special piston is used, but the magnet will not be placed into the groove unless ordered, therefore the adders will be equal for the "2" magnet and "WA" option. When ordering the combination of "2" (reed) magnet and "WA" (wearband) option you will only use the adder once.

Notes on Ordering:

Ports - Full flow 10-32 ports are standard on 3/4" and 1 1/8" bore Compact Series. If you want 1/8" NPTF ports, overall lengths will increase by 7/16" on double rods and 1/2" on single rods due to a thicker head and cap. Full flow 1/8" NPTF ports are standard and 1/4" NPTF ports are not available on 1 1/2" and 2" bore sizes. Full flow 1/4" NPTF ports are standard on 2 1/2" through 4" bore sizes. Smaller ports are available.

Specials - Various special configurations are available: consult factory. Metric rod threads and "G" ports are available by special order. 2A Thread Extension would need to be reviewed and determined if special order is available.

Multiple Options - For multiple options, please consult the factory for "combination" option codes.

Basic Compact Series Cylinders

Dimensions: Inches

3/4" and 1 1/8" Bores

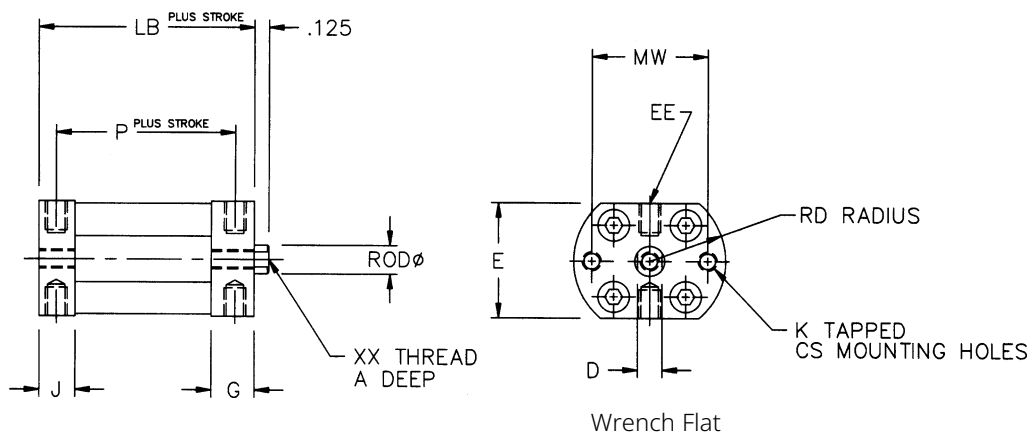

Mount Code S4 (Standard)

1 1/2" Through 4" Bores

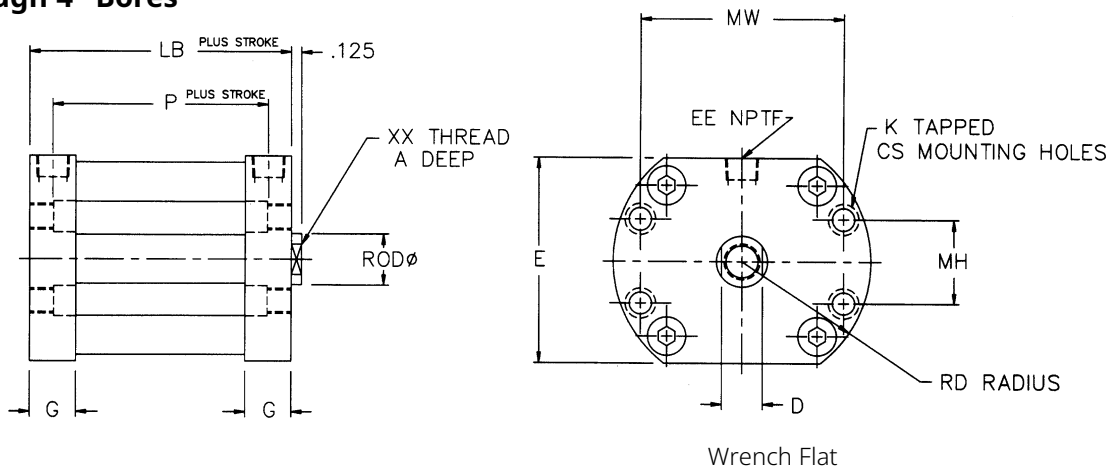

Mount Code XO

| Bore | Rod | A | CS | D | E | EE+ | G | J | K | *LB | MH | MW | P | RD | XX |
|--------|-------|-------|------|-------|-------|--------|-------|-------|---------|-------|-------|-------|-------|-------|---------|
| 3/4" | 0.250 | 0.375 | #5 | 0.212 | 1.250 | #10-32 | 0.406 | 0.343 | #8-32 | 1.000 | N/A | 1.375 | 0.638 | 0.844 | #8-32 |
| 1-1/8" | 0.500 | 0.375 | #6 | 0.375 | 1.750 | #10-32 | 0.406 | 0.343 | #10-32 | 1.000 | N/A | 1.793 | 0.638 | 1.125 | 1/4-28 |
| 1-1/2" | 0.625 | 0.500 | #10 | 0.500 | 2.000 | 1/8 | 0.625 | N/A | 1/4-28 | 1.438 | 0.770 | 2.114 | 0.875 | 1.313 | 7/16-20 |
| 1-1/2" | 0.750 | 0.750 | #10 | 0.625 | 2.000 | 1/8 | 0.625 | N/A | 1/4-28 | 1.438 | 0.770 | 2.114 | 0.875 | 1.313 | 1/2-20 |
| 2" | 0.625 | 0.500 | 1/4 | 0.500 | 2.500 | 1/8 | 0.625 | N/A | 5/16-24 | 1.438 | 1.029 | 2.483 | 0.875 | 1.575 | 7/16-20 |
| 2" | 0.750 | 0.750 | 1/4 | 0.625 | 2.500 | 1/8 | 0.625 | N/A | 5/16-24 | 1.438 | 1.029 | 2.483 | 0.875 | 1.575 | 1/2-20 |
| 2-1/2" | 0.625 | 0.500 | 1/4 | 0.500 | 3.000 | 1/4 | 0.750 | N/A | 5/16-24 | 1.750 | 1.363 | 2.922 | 1.063 | 1.875 | 7/16-20 |
| 2-1/2" | 0.750 | 0.750 | 1/4 | 0.625 | 3.000 | 1/4 | 0.750 | N/A | 5/16-24 | 1.750 | 1.363 | 2.922 | 1.063 | 1.875 | 1/2-20 |
| 3" | 1.000 | 0.875 | 1/4 | 0.875 | 3.500 | 1/4 | 0.750 | N/A | 5/16-24 | 1.875 | 1.585 | 3.399 | 1.188 | 2.125 | 3/4-16 |
| 4" | 1.000 | 0.875 | 5/16 | 0.875 | 4.500 | 1/4 | 0.750 | N/A | 3/8-24 | 1.875 | 2.060 | 4.418 | 1.188 | 2.750 | 3/4-16 |

* Refer to pg. 3 for length adders

Round Head and Cap Mount

Dimensions: Inches

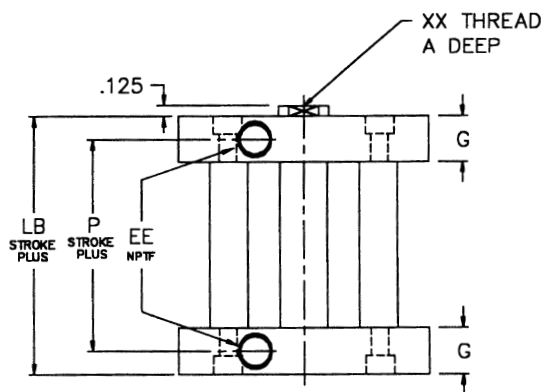
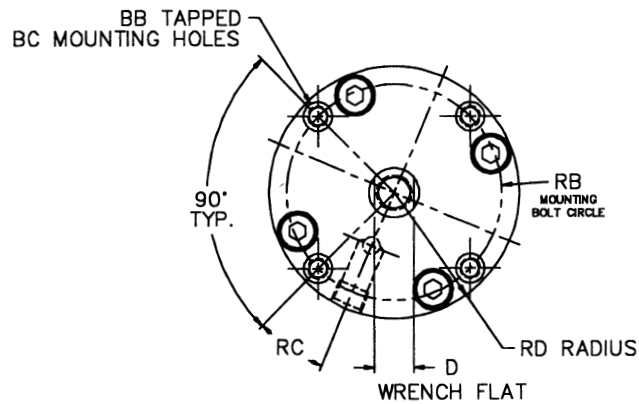

Mount Code R3

| Bore | Rod | A | BB | BC | D | EE+ | G | LB | P | RB | RC | RD | XX |
|--------|-------|-------|---------|------|-------|--------|-------|-------|-------|-------|-----|-------|---------|
| 3/4" | 0.250 | 0.375 | #10-32 | #6 | 0.212 | #10-32 | 0.406 | 1.013 | 0.638 | 1.219 | 35° | 0.750 | #8-32 |
| 1-1/8" | 0.500 | 0.375 | #10-32 | #6 | 0.375 | #10-32 | 0.406 | 1.013 | 0.638 | 1.688 | 20° | 1.000 | 1/4-28 |
| 1-1/2" | 0.625 | 0.500 | 1/4-28 | #10 | 0.500 | 1/8 | 0.625 | 1.438 | 0.875 | 2.188 | 21° | 1.313 | 7/16-20 |
| 1-1/2" | 0.750 | 0.750 | 1/4-28 | #10 | 0.625 | 1/8 | 0.625 | 1.438 | 0.875 | 2.188 | 21° | 1.313 | 1/2-20 |
| 2" | 0.625 | 0.500 | 1/4-28 | #10 | 0.500 | 1/8 | 0.625 | 1.438 | 0.875 | 2.688 | 22° | 1.563 | 7/16-20 |
| 2" | 0.750 | 0.750 | 1/4-28 | #10 | 0.625 | 1/8 | 0.625 | 1.438 | 0.875 | 2.688 | 22° | 1.563 | 1/2-20 |
| 2-1/2" | 0.625 | 0.500 | 5/16-24 | 1/4 | 0.500 | 1/4 | 0.750 | 1.750 | 1.063 | 3.250 | 25° | 1.875 | 7/16-20 |
| 2-1/2" | 0.750 | 0.750 | 5/16-24 | 1/4 | 0.625 | 1/4 | 0.750 | 1.750 | 1.063 | 3.250 | 25° | 1.875 | 1/2-20 |
| 3" | 1.000 | 0.875 | 5/16-24 | 1/4 | 0.875 | 1/4 | 0.750 | 1.875 | 1.188 | 3.781 | 21° | 2.125 | 3/4-16 |
| 4" | 1.000 | 0.875 | 3/8-24 | 5/16 | 0.875 | 1/4 | 0.750 | 1.875 | 1.188 | 4.938 | 21° | 2.750 | 3/4-16 |

Flange Mounts

Dimensions: Inches

Front Flange

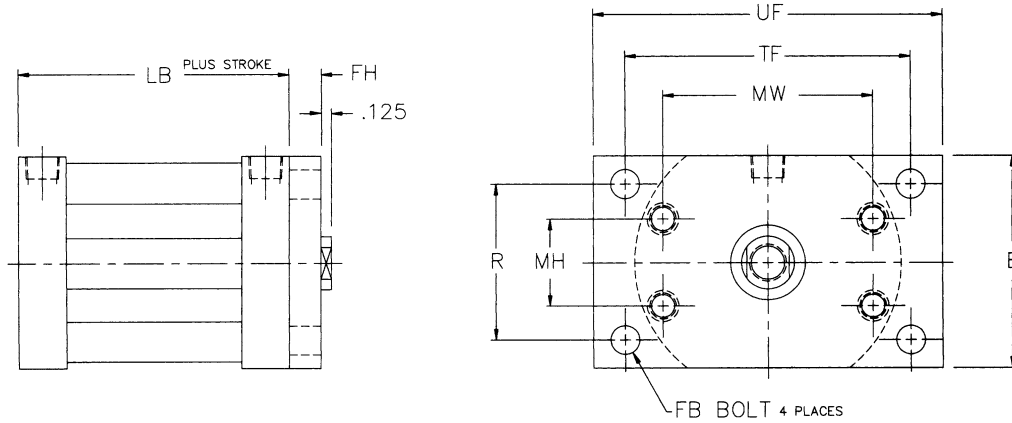

Mount Code F1

Rear Flange

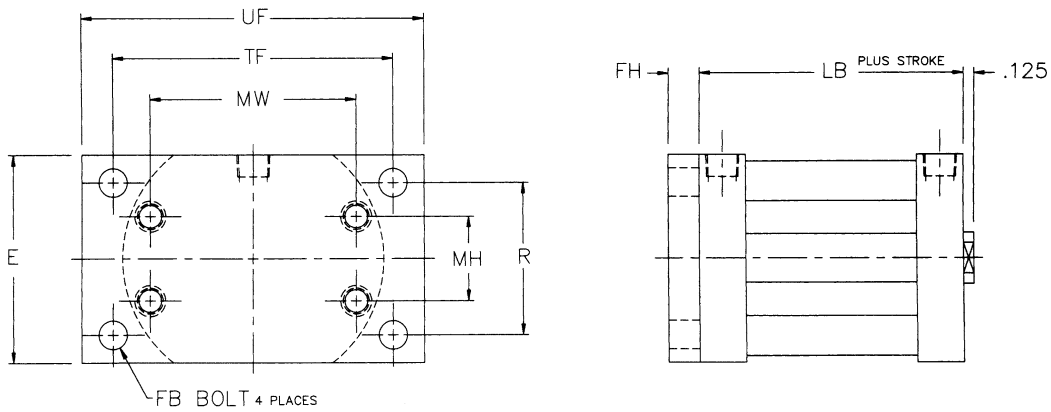

Mount Code F2

| Bore | E | FB | FH | LB | MH | MW | R | TF | UF |
|--------|-------|------|-------|-------|-------|-------|-------|-------|-------|
| 3/4" | 0.250 | #8 | 0.250 | 0.950 | N/A | 1.375 | 0.813 | 1.813 | 2.250 |
| 1-1/8" | 0.750 | #10 | 0.250 | 0.950 | N/A | 1.793 | 1.282 | 2.250 | 2.750 |
| 1-1/2" | 2.000 | 5/16 | 0.375 | 1.438 | 0.770 | 2.114 | 1.430 | 2.750 | 3.375 |
| 2" | 2.500 | 3/8 | 0.375 | 1.438 | 1.029 | 2.483 | 1.840 | 3.375 | 4.125 |
| 2-1/2" | 3.000 | 3/8 | 0.375 | 1.750 | 1.363 | 2.922 | 2.190 | 3.875 | 4.625 |
| 3" | 3.500 | 5/16 | 0.438 | 1.875 | 1.585 | 3.399 | 2.625 | 4.375 | 5.000 |
| 4" | 4.500 | 7/16 | 0.625 | 1.875 | 2.060 | 4.418 | 3.320 | 5.438 | 6.250 |

Clevis Mounts

Dimensions: Inches

Fixed Clevis

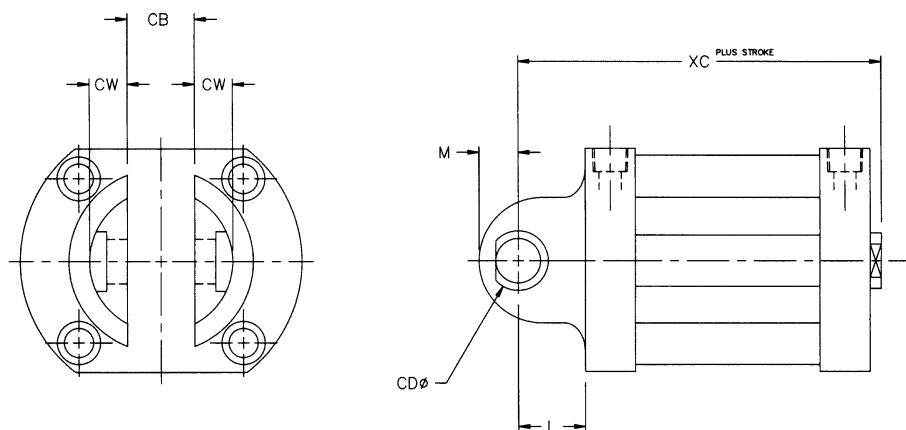

Mount Code P1

NOTE: Includes clevis pin.

Detachable Clevis

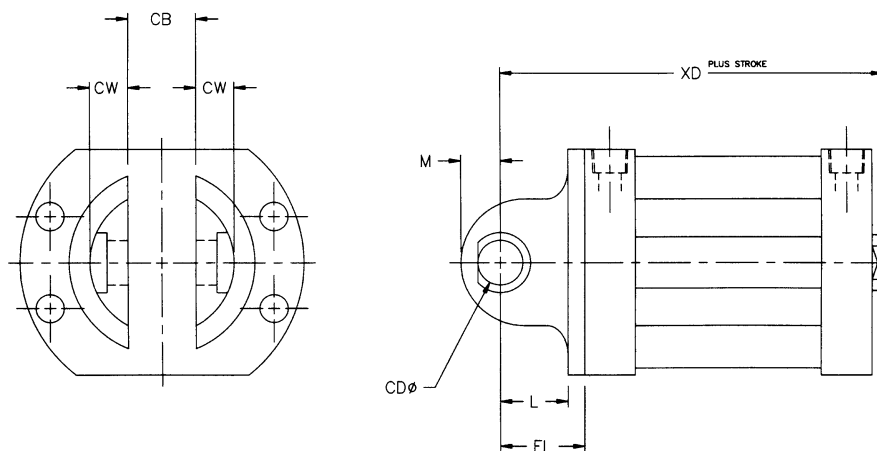

Mount Code P2

NOTE: Includes clevis pin.

| Bore | CB | CD | CW | FL | L | M | XC | XD |
|--------|-------|-------|-------|-------|-------|-------|-------|-------|
| 3/4" | 0.375 | 0.188 | 0.302 | 0.688 | 0.500 | 0.474 | N/A | 1.763 |
| 1-1/8" | 0.375 | 0.188 | 0.302 | 0.688 | 0.500 | 0.474 | N/A | 1.763 |
| 1-1/2" | 0.750 | 0.375 | 0.424 | 0.813 | 0.625 | 0.438 | 2.188 | 2.375 |
| 2" | 0.750 | 0.375 | 0.424 | 0.938 | 0.750 | 0.438 | 2.313 | 2.500 |
| 2-1/2" | 0.750 | 0.375 | 0.424 | 1.000 | 0.750 | 0.500 | 2.625 | 2.875 |
| 3" | 1.000 | 0.625 | 0.553 | 1.313 | 1.063 | 0.625 | 3.063 | 3.313 |
| 4" | 1.000 | 0.625 | 0.553 | 1.688 | 1.438 | 0.625 | 3.438 | 3.688 |

Eye Mounts

Dimensions: Inches

Fixed Eye

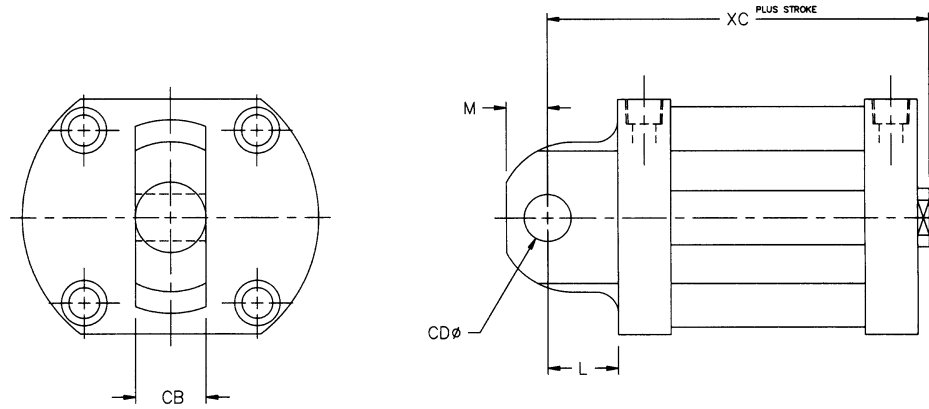

Mount Code P3

NOTE: Includes clevis pin.

Detachable Eye

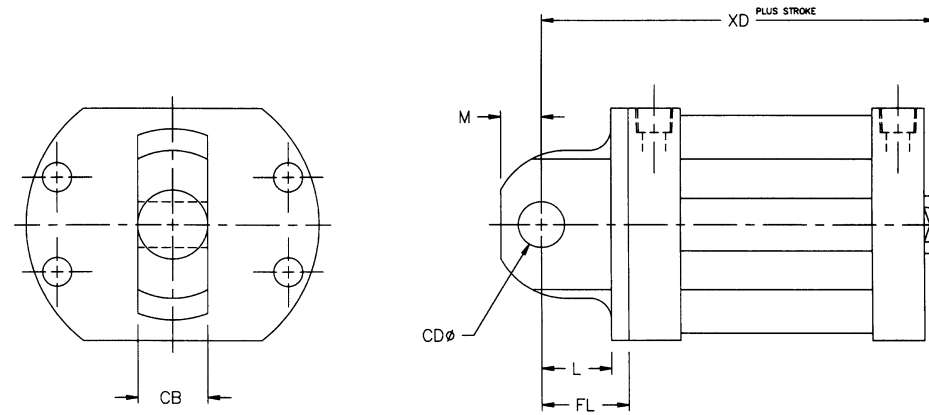

Mount Code P4

NOTE: Includes clevis pin.

| Bore | CB | CD | FL | L | M | XC | XD |
|--------|-------|-------|-------|-------|-------|-------|-------|
| 3/4" | 0.375 | 0.188 | 0.688 | 0.500 | 0.490 | N/A | 1.763 |
| 1-1/8" | 0.375 | 0.188 | 0.688 | 0.500 | 0.490 | N/A | 1.763 |
| 1-1/2" | 0.750 | 0.375 | 0.813 | 0.625 | 0.438 | 2.188 | 2.375 |
| 2" | 0.750 | 0.375 | 0.938 | 0.750 | 0.438 | 2.313 | 2.500 |
| 2-1/2" | 0.750 | 0.375 | 1.000 | 0.750 | 0.500 | 2.625 | 2.875 |
| 3" | 1.000 | 0.625 | 1.313 | 1.063 | 0.625 | 3.063 | 3.313 |
| 4" | 1.000 | 0.625 | 1.688 | 1.438 | 0.625 | 3.438 | 3.688 |

Bottom Mounts

Dimensions: Inches

3/4" And 1 1/8" Bores - Bottom Tapped (Standard)

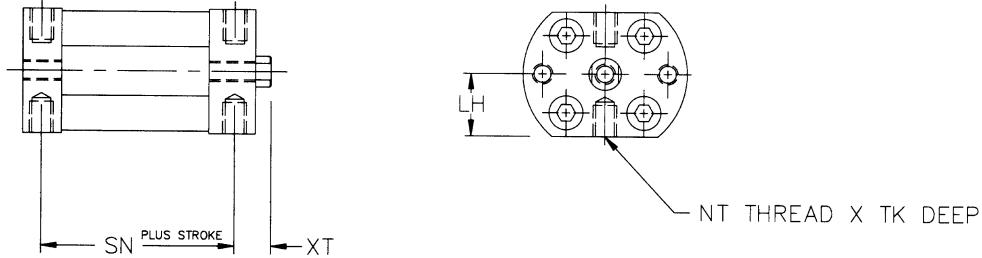

Mount Code S4 (Standard)

1 1/2" Through 4" Bores - Bottom Tapped

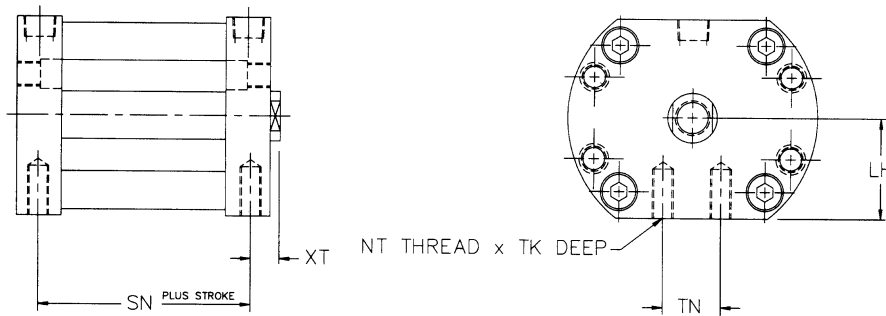

Mount Code S4

1 1/2" Through 4" Bores - Base Bar Mount

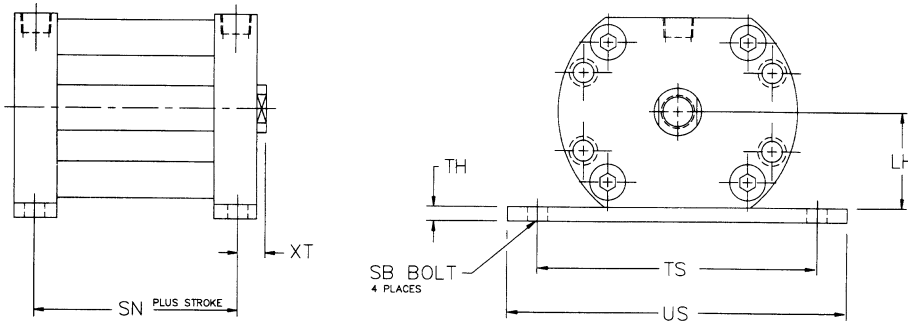

Mount Code S2

| Bore | LH | NT | SB | SN | TH | TK | TN | TS | US | XT |
|--------|-------|---------|------|-------|-------|-------|-------|-------|-------|-------|
| 3/4" | 0.625 | #10-32 | N/A | 0.638 | N/A | 0.250 | N/A | N/A | N/A | 0.293 |
| 1-1/8" | 0.875 | #10-32 | N/A | 0.638 | N/A | 0.250 | N/A | N/A | N/A | 0.293 |
| 1-1/2" | 1.000 | 1/4-28 | 1/4 | 0.813 | 0.250 | 0.375 | 0.625 | 2.875 | 3.375 | 0.438 |
| 2" | 1.250 | 1/4-28 | 1/4 | 0.813 | 0.250 | 0.375 | 0.750 | 3.375 | 3.875 | 0.438 |
| 2-1/2" | 1.500 | 5/16-24 | 5/16 | 1.000 | 0.250 | 0.500 | 1.125 | 4.000 | 4.375 | 0.500 |
| 3" | 1.750 | 5/16-24 | 5/16 | 1.125 | 0.375 | 0.500 | 1.625 | 4.500 | 4.875 | 0.500 |
| 4" | 2.250 | 3/8-24 | 3/8 | 1.125 | 0.375 | 0.750 | 1.625 | 5.750 | 6.250 | 0.500 |

Single Acting Cylinders
Dimensions: Inches

Spring Extend

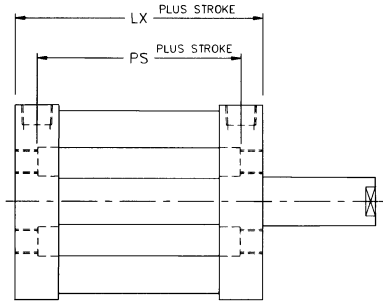

Order as "SE" option

Spring Return

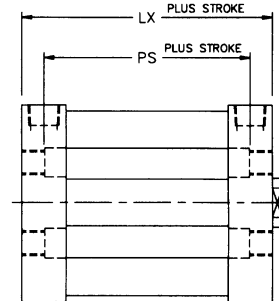

Order as "SR" option

Bottom Tapped with SE or SR option

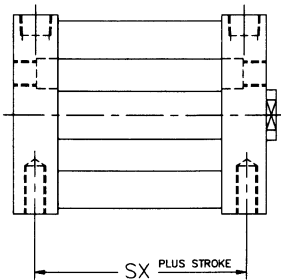

Mount Code S4

Base Bar Mount with SE or SR option

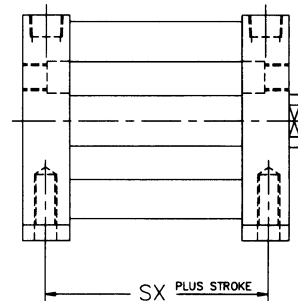

Mount Code S2

(Consult factory for strokes greater than 2")

| Bore | Strokes up to 1" | | | | | Strokes over 1" up to 2" | | | | |
|--------|------------------|-------|-------|-------|-------|--------------------------|-------|-------|-------|-------|
| | LX | PS | SX | XV | XY | LX | PS | SX | XV | XY |
| 3/4" | 1.950 | 1.638 | 1.638 | N/A | 2.763 | 2.950 | 2.638 | 2.638 | N/A | 3.763 |
| 1-1/8" | 1.950 | 1.638 | 1.638 | N/A | 2.763 | 2.950 | 2.638 | 2.638 | N/A | 3.763 |
| 1-1/2" | 2.688 | 2.125 | 2.063 | 3.438 | 3.625 | 3.938 | 3.375 | 3.313 | 4.688 | 4.875 |
| 2" | 2.813 | 2.250 | 2.188 | 3.688 | 3.875 | 4.188 | 3.625 | 3.563 | 5.063 | 5.250 |
| 2-1/2" | 3.125 | 2.438 | 2.375 | 4.000 | 4.250 | 4.500 | 3.813 | 3.750 | 5.375 | 5.625 |
| 3" | 3.375 | 2.688 | 2.625 | 4.563 | 4.813 | 4.875 | 4.188 | 4.125 | 6.063 | 6.313 |
| 4" | 3.375 | 2.688 | 2.625 | 4.938 | 5.188 | 4.875 | 4.188 | 4.125 | 6.438 | 6.688 |

Single Acting Cylinders Cylinders

Dimensions: Inches

Detachable Eye with SE or SR option

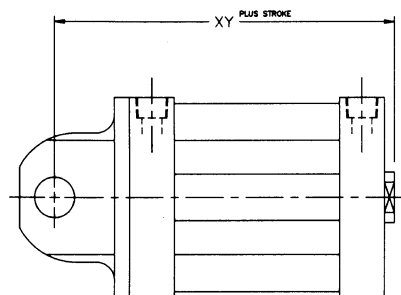

Mount Code P4

Detachable Clevis with SE or SR option

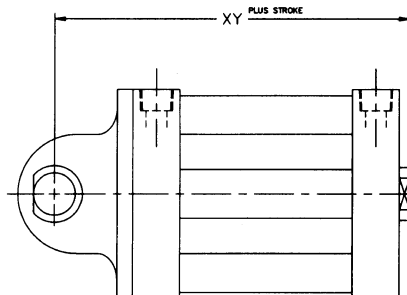

Mount Code P2

Fixed Eye with SE or SR option

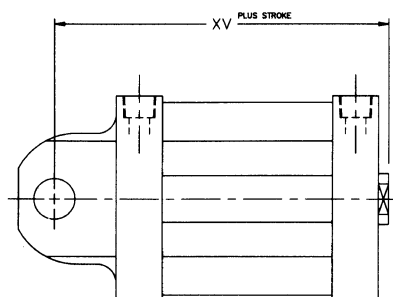

Mount Code P3

Fixed Clevis with SE or SR option

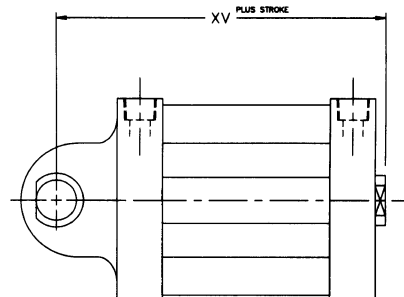

Mount Code P1

(Consult factory for strokes greater than 2")

| Bore | Strokes up to 1" | | | | | Strokes over 1" up to 2" | | | | |
|--------|------------------|-------|-------|-------|-------|--------------------------|-------|-------|-------|-------|
| | LX | PS | SX | XV | XY | LX | PS | SX | XV | XY |
| 3/4" | 1.950 | 1.638 | 1.638 | N/A | 2.763 | 2.950 | 2.638 | 2.638 | N/A | 3.763 |
| 1-1/8" | 1.950 | 1.638 | 1.638 | N/A | 2.763 | 2.950 | 2.638 | 2.638 | N/A | 3.763 |
| 1-1/2" | 2.688 | 2.125 | 2.063 | 3.438 | 3.625 | 3.938 | 3.375 | 3.313 | 4.688 | 4.875 |
| 2" | 2.813 | 2.250 | 2.188 | 3.688 | 3.875 | 4.188 | 3.625 | 3.563 | 5.063 | 5.250 |
| 2-1/2" | 3.125 | 2.438 | 2.375 | 4.000 | 4.250 | 4.500 | 3.813 | 3.750 | 5.375 | 5.625 |
| 3" | 3.375 | 2.688 | 2.625 | 4.563 | 4.813 | 4.875 | 4.188 | 4.125 | 6.063 | 6.313 |
| 4" | 3.375 | 2.688 | 2.625 | 4.938 | 5.188 | 4.875 | 4.188 | 4.125 | 6.438 | 6.688 |

Double Rod Cylinders
Dimensions: Inches

3/4" and 1 1/8" Bores

This configuration has a piston rod which extends out both ends of the cylinder. It is also called a through rod cylinder.

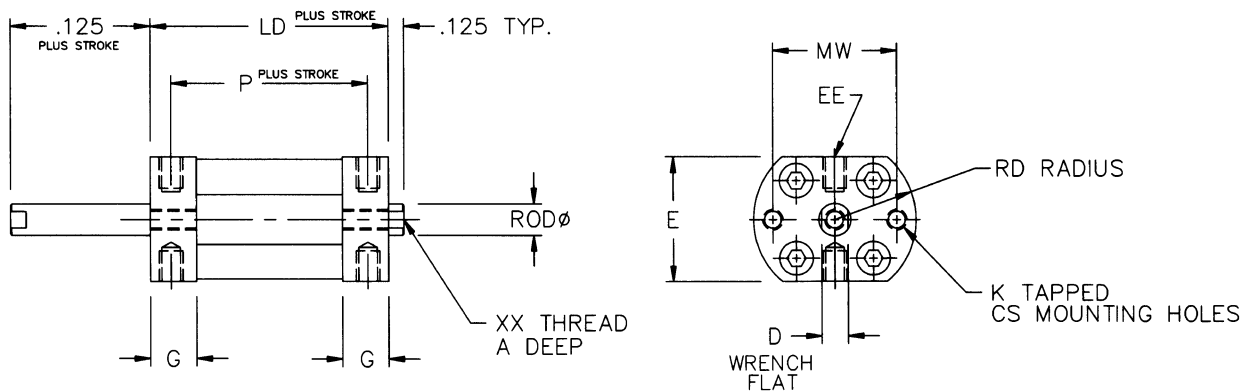

Order as "DA" Option

1 1/2" Through 4" Bores

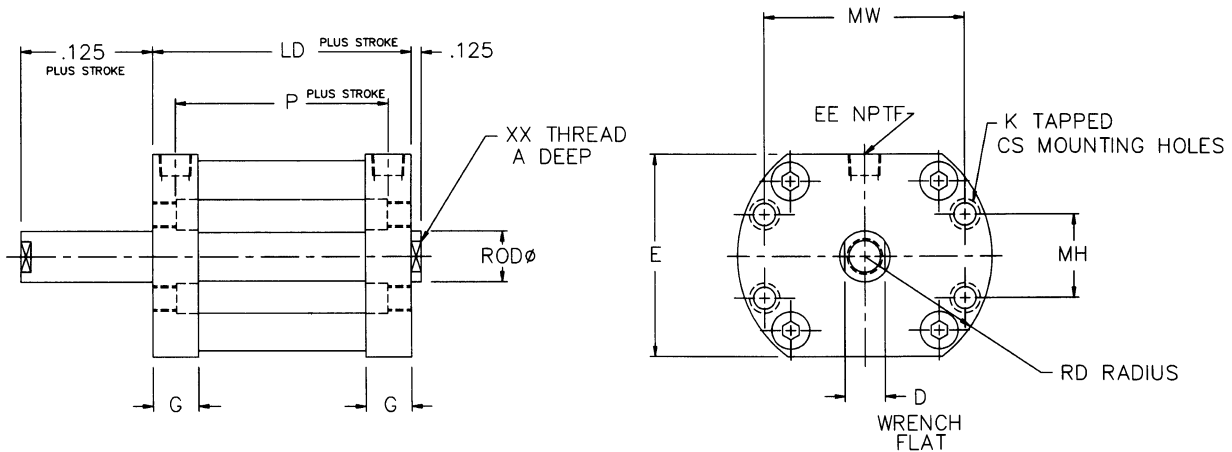

Order as "DA" Option

| Bore | Rod | A | CS | D | E | EE+ | G | K | LD | MH | MW | P | RD | XX |
|--------|-------|-------|------|-------|-------|--------|-------|---------|-------|-------|-------|-------|-------|---------|
| 3/4" | 0.250 | 0.375 | #5 | 0.212 | 1.250 | #10-32 | 0.406 | #8-32 | 1.000 | N/A | 1.375 | 0.678 | 0.844 | #8-32 |
| 1-1/8" | 0.500 | 0.375 | #6 | 0.375 | 1.750 | #10-32 | 0.406 | #10-32 | 1.000 | N/A | 1.793 | 0.678 | 1.125 | 1/4-28 |
| 1-1/2" | 0.625 | 0.500 | #10 | 0.500 | 2.000 | 1/8 | 0.625 | 1/4-28 | 1.438 | 0.770 | 2.114 | 0.875 | 1.313 | 7/16-20 |
| 1-1/2" | 0.750 | 0.750 | #10 | 0.625 | 2.000 | 1/8 | 0.625 | 1/4-28 | 1.438 | 0.770 | 2.114 | 0.875 | 1.313 | 1/2-20 |
| 2" | 0.625 | 0.500 | 1/4 | 0.500 | 2.500 | 1/8 | 0.625 | 5/16-24 | 1.438 | 1.029 | 2.483 | 0.875 | 1.575 | 7/16-20 |
| 2" | 0.750 | 0.750 | 1/4 | 0.625 | 2.500 | 1/8 | 0.625 | 5/16-24 | 1.438 | 1.029 | 2.483 | 0.875 | 1.575 | 1/2-20 |
| 2-1/2" | 0.625 | 0.500 | 1/4 | 0.500 | 3.000 | 1/4 | 0.750 | 5/16-24 | 1.750 | 1.363 | 2.922 | 1.063 | 1.875 | 7/16-20 |
| 2-1/2" | 0.750 | 0.750 | 1/4 | 0.625 | 3.000 | 1/4 | 0.750 | 5/16-24 | 1.750 | 1.363 | 2.922 | 1.063 | 1.875 | 1/2-20 |
| 3" | 1.000 | 0.875 | 1/4 | 0.875 | 3.500 | 1/4 | 0.750 | 5/16-24 | 1.875 | 1.585 | 3.399 | 1.188 | 2.125 | 3/4-16 |
| 4" | 1.000 | 0.875 | 5/16 | 0.875 | 4.500 | 1/4 | 0.750 | 3/8-24 | 1.875 | 2.060 | 4.418 | 1.188 | 2.750 | 3/4-16 |

How to Order C Series Pancake

Leave blank unless using MU or BK option.

CX C L - 04 A 9 B - A AA 0 04 0

Mount

CX = Round head/cap
 CA = Thread mount holes both ends
 CB = Thread mount holes head
 CC = Thread mount holes cap
 CD = Screw Clearance holes both
 CE = Screw Clearance holes head
 CF = Screw Clearance holes cap

Type

C = Compact Cylinder Line

Bore

C = 3/4"
 G = 1-1/8"
 K = 1-1/2"
 L = 2"
 M = 2-1/2"
 N = 3"
 R = 4"

Full Inches of Stoke

00 = 0" Stoke
 01 = 1" Stoke
 02 = 2" Stoke
 03 = 3" Stoke
 20 = 20" Stoke

Fractional Inches of Stoke

A = 0" I = 1/2"
 B = 1/16" J = 9/16"
 C = 1/8" K = 5/8"
 D = 3/16" L = 11/16"
 E = 1/4" M = 3/4"
 F = 5/16" N = 13/16"
 G = 3/8" O = 7/8"
 H = 7/16" P = 15/16"

Rod End code

Determined by bore size
 9 = Fine female
 * Standard rod end

Fractional Inches of Stoke

A = 0" I = 1/2"
 B = 1/16" J = 9/16"
 C = 1/8" K = 5/8"
 D = 3/16" L = 11/16"
 E = 1/4" M = 3/4"
 F = 5/16" N = 13/16"
 G = 3/8" O = 7/8"
 H = 7/16" P = 15/16"

Full Inches of Stoke

00 = 0" Stoke
 01 = 1" Stoke
 02 = 2" Stoke
 03 = 3" Stoke

Magnet Piston

4 = Electronic switch magnet

Options

AA = No options
 BC = Bumper Cap
 BH = bumper head
 FM = Fine Male
 CF = Coarse female
 CM = Coarse Male
 VA = Viton Seals
 WA = Wear band
 1A = Rod extension

Cushions

A = No Cushions

Ports

Position# 10-32 *1/8" *1/4"
 1 A B C

Cylinder Orientation

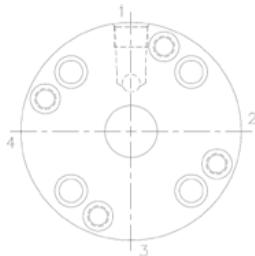

Ports Normally in Position 1

Rod End Styles, Diameters and Threads

| Bore | Diameter | Standard | FM | CF | CM |
|--------|----------|----------|---------|---------|---------|
| 3/4" | 0.312 | 10-32 | 10-32 | 10-24 | 10-24 |
| 1 1/8" | 0.5 | 5/16-24 | 5/16-24 | 5/16-18 | 5/16-18 |
| 1 1/2" | 0.625 | 3/8-24 | 3/8-24 | 3/8-16 | 3/8-16 |
| 2" | 0.750 | 1/2-20 | 1/2-20 | 1/2-13 | 1/2-13 |
| 2 1/2" | 0.750 | 1/2-20 | 1/2-20 | 1/2-13 | 1/2-13 |
| 3" | 1.000 | 5/8-18 | 5/8-18 | 5/8-11 | 5/8-11 |
| 4" | 1.000 | 3/4-16 | 3/4-16 | 3/4-10 | 3/4-10 |

C Series – Pancake Style

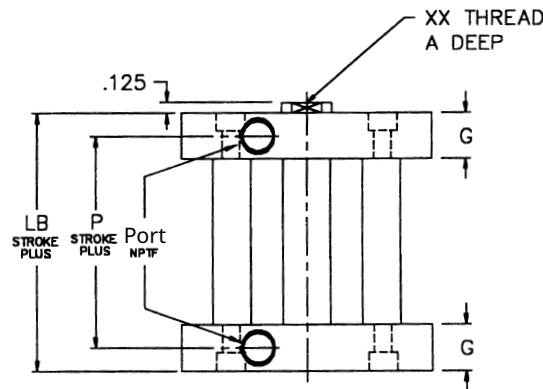
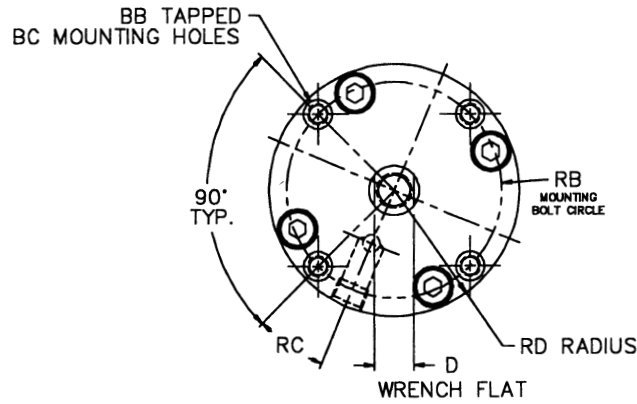

C series Pancake

| Bore | Rod | Port | BB | BB C'Bore | BC | D | G | LB | P | RB | RC Degree | RD |
|-------|-------|---------|---------|----------------|------|-------|-------|-------|-------|-------|-----------|-------|
| 3/4 | 0.312 | 10-32 | #10-32 | 0.24 x 0.15 dp | #6 | 0.312 | 0.406 | 1.013 | 0.638 | 1.219 | 35 | 0.75 |
| 1-1/8 | 0.5 | 1/8 NPT | #10-32 | 0.24 x 0.15 dp | #6 | 0.5 | 0.406 | 1.438 | 0.638 | 1.688 | 20 | 1 |
| 1-1/2 | 0.625 | 1/8 NPT | 1/4-28 | 0.34 x 0.22 dp | #10 | 0.625 | 0.625 | 1.438 | 0.875 | 2.188 | 21 | 1.313 |
| 2 | 0.75 | 1/8 NPT | 1/4-28 | 0.34 x 0.22 dp | #10 | 0.75 | 0.75 | 1.438 | 0.875 | 2.688 | 22 | 1.563 |
| 2-1/2 | 0.75 | 1/4 NPT | 5/16-24 | 0.40 x 0.27 dp | 1/4 | 0.75 | 0.75 | 1.75 | 1.063 | 3.25 | 25 | 1.875 |
| 3 | 1 | 1/4 NPT | 5/16-24 | 0.40 x 0.27 dp | 1/4 | 1 | 0.75 | 1.875 | 1.188 | 3.871 | 21 | 2.125 |
| 4 | 1 | 1/4 NPT | 3/8-24 | 0.49 x 0.33 dp | 5/16 | 1 | 0.75 | 1.875 | 1.188 | 4.938 | 21 | 2.75 |

Back to Back Cylinders

Dimensions: Inches

3/4" and 1 1/8" Bores

This configuration is two cylinders mounted back to back. Each cylinder can be operated independently. The cylinders can have the same stroke or different strokes. This configuration enables you to have four combinations of rods extended or retracted.

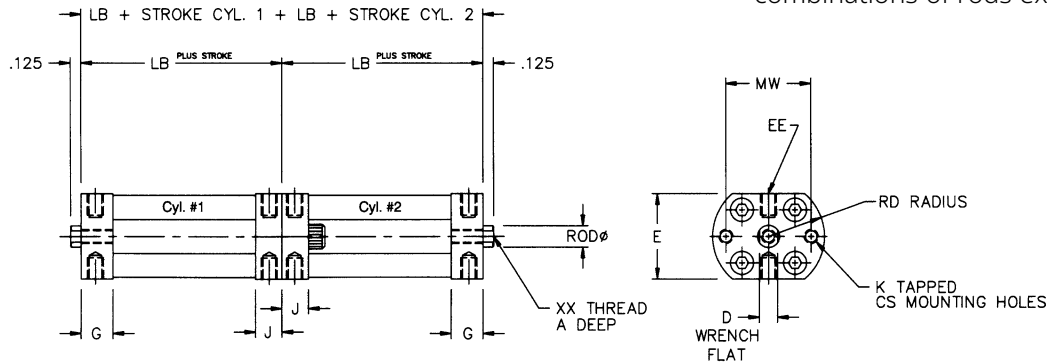

Consult factory for ordering.

1 1/2" Through 4" Bores

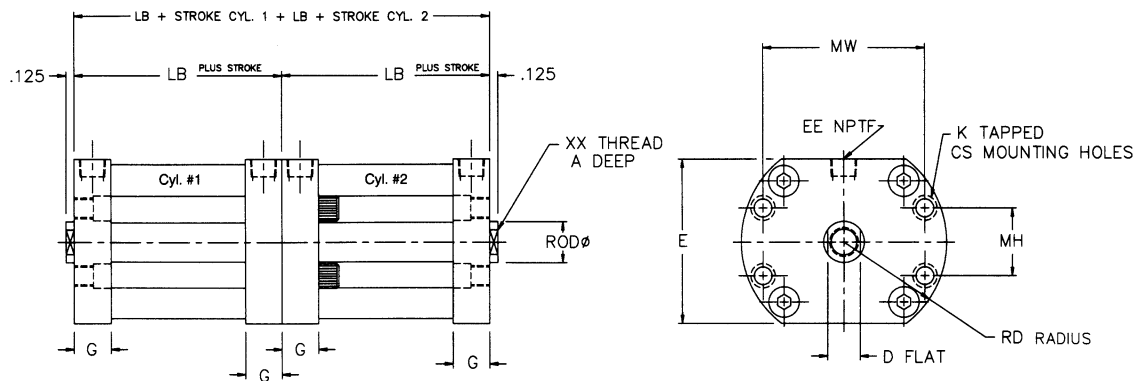

Consult factory for ordering.

| Bore | Rod | A | CS | D | E | EE | G | J | K | LB | MH | MW | RD | XX |
|--------|-------|-------|------|-------|-------|--------|-------|-------|---------|-------|-------|-------|-------|---------|
| 1-1/8" | 0.500 | 0.375 | #6 | 0.375 | 1.750 | #10-32 | 0.406 | 0.343 | #10-32 | 0.950 | N/A | 1.793 | 1.125 | 1/4-28 |
| 1-1/2" | 0.625 | 0.500 | #10 | 0.500 | 2.000 | 1/8 | 0.625 | N/A | 1/4-28 | 1.438 | 0.770 | 2.114 | 1.313 | 7/16-20 |
| 1-1/2" | 0.750 | 0.750 | #10 | 0.625 | 2.000 | 1/8 | 0.625 | N/A | 1/4-28 | 1.438 | 0.770 | 2.114 | 1.313 | 1/2-20 |
| 2" | 0.625 | 0.500 | 1/4 | 0.500 | 2.500 | 1/8 | 0.625 | N/A | 5/16-24 | 1.438 | 1.029 | 2.483 | 1.575 | 7/16-20 |
| 2" | 0.750 | 0.750 | 1/4 | 0.625 | 2.500 | 1/8 | 0.625 | N/A | 5/16-24 | 1.438 | 1.029 | 2.483 | 1.575 | 1/2-20 |
| 2-1/2" | 0.625 | 0.500 | 1/4 | 0.500 | 3.000 | 1/4 | 0.750 | N/A | 5/16-24 | 1.750 | 1.363 | 2.922 | 1.875 | 7/16-20 |
| 2-1/2" | 0.750 | 0.750 | 1/4 | 0.625 | 3.000 | 1/4 | 0.750 | N/A | 5/16-24 | 1.750 | 1.363 | 2.922 | 1.875 | 1/2-20 |
| 3" | 1.000 | 0.875 | 1/4 | 0.875 | 3.500 | 1/4 | 0.750 | N/A | 5/16-24 | 1.875 | 1.585 | 3.399 | 2.125 | 3/4-16 |
| 4" | 1.000 | 0.875 | 5/16 | 0.875 | 4.500 | 1/4 | 0.750 | N/A | 3/8-24 | 1.875 | 2.060 | 4.418 | 2.750 | 3/4-16 |

Tandem Cylinders
Dimensions: Inches

This configuration provides nearly twice the force of an equivalent basic double acting cylinder. Two pistons are attached to a common piston rod. Ports 2 and 4 are pressurized to nearly double the extend force. Ports 1 and 3 are pressurized to double the retract force.

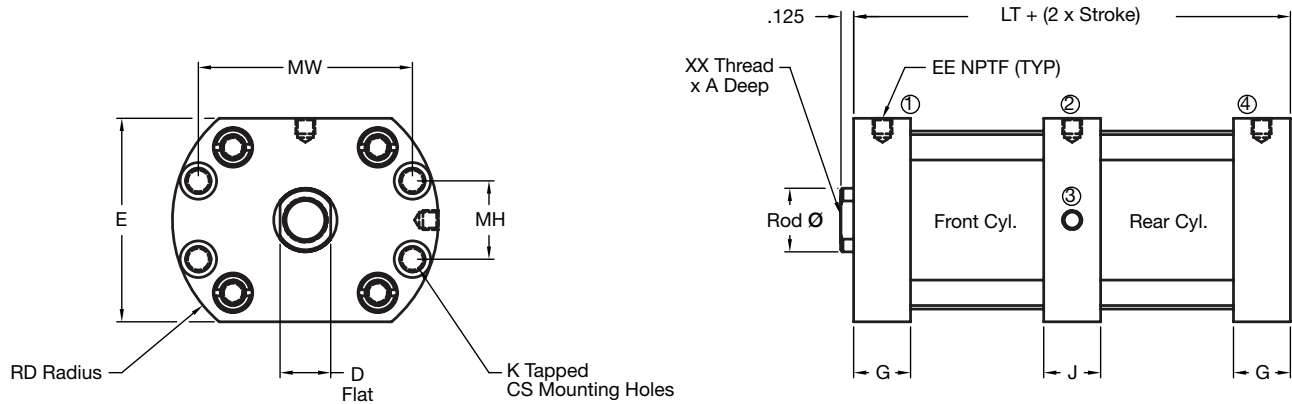

| Bore | Rod | A | CS | D | E | EE | G | J | K | LT | MH | MW | RD | XX |
|--------|-------|-------|------|-------|-------|-----|-------|-------|---------|-------|-------|-------|-------|---------|
| 1-1/2" | 0.625 | 0.500 | #10 | 0.500 | 2.000 | 1/8 | 0.625 | 0.688 | 1/4-28 | 2.313 | 0.770 | 2.114 | 1.313 | 7/16-20 |
| 1-1/2" | 0.750 | 0.750 | #10 | 0.625 | 2.000 | 1/8 | 0.625 | 0.688 | 1/4-28 | 2.313 | 0.770 | 2.114 | 1.313 | 1/2-20 |
| 2" | 0.625 | 0.500 | 1/4 | 0.500 | 2.500 | 1/8 | 0.625 | 0.688 | 5/16-24 | 2.313 | 1.029 | 2.483 | 1.575 | 7/16-20 |
| 2" | 0.750 | 0.750 | 1/4 | 0.625 | 2.500 | 1/8 | 0.625 | 0.688 | 5/16-24 | 2.313 | 1.029 | 2.483 | 1.575 | 1/2-20 |
| 2-1/2" | 0.625 | 0.500 | 1/4 | 0.500 | 3.000 | 1/4 | 0.750 | 0.813 | 5/16-24 | 2.313 | 1.363 | 2.922 | 1.875 | 7/16-20 |
| 2-1/2" | 0.750 | 0.750 | 1/4 | 0.625 | 3.000 | 1/4 | 0.750 | 0.813 | 5/16-24 | 2.313 | 1.363 | 2.922 | 1.875 | 1/2-20 |
| 3" | 1.000 | 0.875 | 1/4 | 0.875 | 3.500 | 1/4 | 0.750 | 0.813 | 5/16-24 | 3.063 | 1.585 | 3.399 | 2.125 | 3/4-16 |
| 4" | 1.000 | 0.875 | 5/16 | 0.875 | 4.500 | 1/4 | 0.750 | 0.813 | 3/8-24 | 3.063 | 2.060 | 4.418 | 2.750 | 3/4-16 |

Multi-Position Cylinders

Dimensions: Inches

Multi-position cylinders look similar to tandem cylinders. However, in this cylinder the rear and front piston rods are separate. The stroke from full retract to the intermediate extend point is set by the stroke of cylinder #2. The total stroke for full retract to full extend is set by the stroke of cylinder #1. Full extend or retract is achieved by pressurizing ports 1 and 2 respectively with ports 3 and 4 vented. An intermediate position is achieved by pressurizing port 4 with the other ports vented or by pressurizing both ports 1 and 4. With 1 and 4 pressurized, the rod is more positively held in the intermediate position.

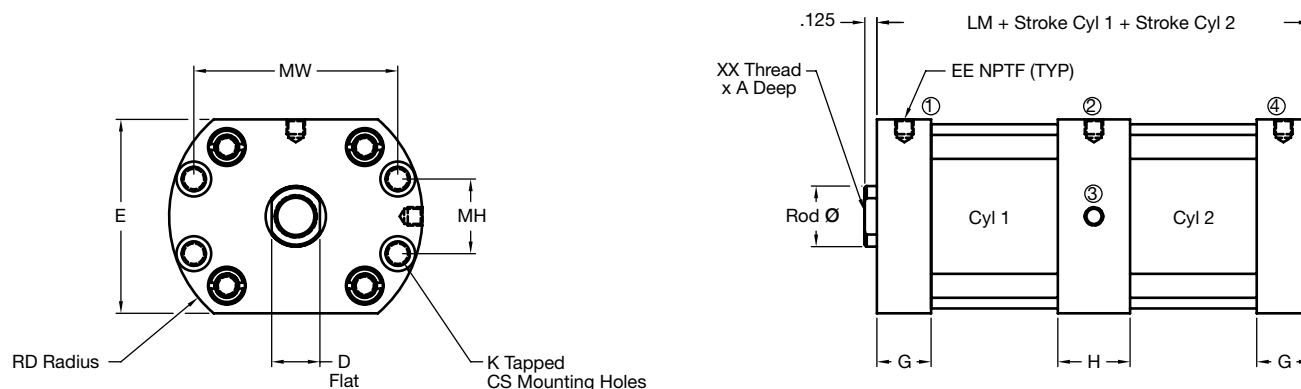

| Bore | Rod | A | CS | D | E | EE | G | H | K | LM | MH | MW | RD | XX |
|--------|-------|-------|------|-------|-------|-----|-------|-------|---------|-------|-------|-------|-------|---------|
| 1-1/2" | 0.625 | 0.500 | #10 | 0.500 | 2.000 | 1/8 | 0.625 | 0.688 | 1/4-28 | 2.500 | 0.770 | 2.114 | 1.313 | 7/16-20 |
| 1-1/2" | 0.750 | 0.750 | #10 | 0.625 | 2.000 | 1/8 | 0.625 | 0.688 | 1/4-28 | 2.500 | 0.770 | 2.114 | 1.313 | 1/2-20 |
| 2" | 0.625 | 0.500 | 1/4 | 0.500 | 2.500 | 1/8 | 0.625 | 0.688 | 5/16-24 | 2.500 | 1.029 | 2.483 | 1.575 | 7/16-20 |
| 2" | 0.750 | 0.750 | 1/4 | 0.625 | 2.500 | 1/8 | 0.625 | 0.688 | 5/16-24 | 2.500 | 1.029 | 2.483 | 1.575 | 1/2-20 |
| 2-1/2" | 0.625 | 0.500 | 1/4 | 0.500 | 3.000 | 1/4 | 0.750 | 0.813 | 5/16-24 | 3.000 | 1.363 | 2.922 | 1.875 | 7/16-20 |
| 2-1/2" | 0.750 | 0.750 | 1/4 | 0.625 | 3.000 | 1/4 | 0.750 | 0.813 | 5/16-24 | 3.000 | 1.363 | 2.922 | 1.875 | 1/2-20 |
| 3" | 1.000 | 0.875 | 1/4 | 0.875 | 3.500 | 1/4 | 0.750 | 0.813 | 5/16-24 | 3.375 | 1.585 | 3.399 | 2.125 | 3/4-16 |
| 4" | 1.000 | 0.875 | 5/16 | 0.875 | 4.500 | 1/4 | 0.750 | 0.813 | 3/8-24 | 3.375 | 2.060 | 4.418 | 2.750 | 3/4-16 |

Accessories

Dimensions: Inches

Clevis Bracket

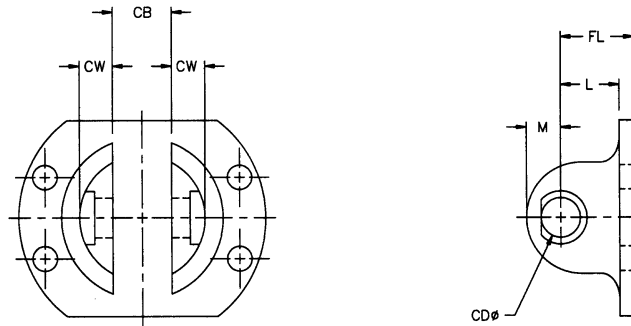

Note: Only two mounting holes on the 3/4" and 1-1/8" bore sizes.

Eye Bracket

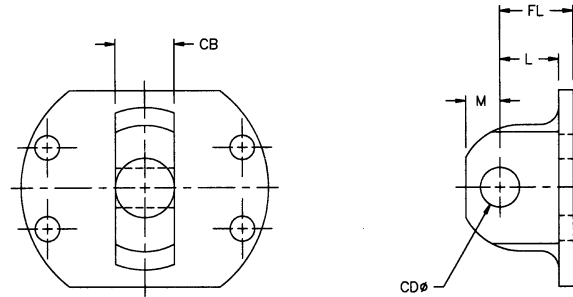

Base Bar

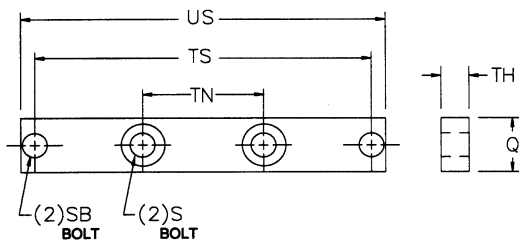

Clevis Pins - 3/4" and 1 1/8" Bores *

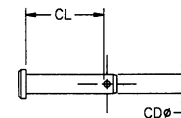

Clevis Pins - 1 1/2" Through 4" Bores *

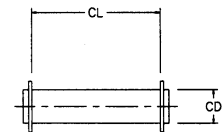

* Included with P1, P2, P3 and P4 mounts

| Bore | Clevis Kit | Eye Kit | Pivot PIN | CB | CD | CL | CW | FL | L | M Clevis | M Eye | Q | S | SB | TH | TN | TS | US |
|--------|------------|----------|-----------|-------|-------|-------|-------|-------|-------|-------------|-------|-------|------|------|-------|-------|-------|-------|
| 3/4" | C600-C05 | C600-C06 | N131-1014 | 0.375 | 0.188 | 1.100 | 0.302 | 0.688 | 0.500 | 0.474 | 0.490 | N/A | N/A | N/A | N/A | N/A | N/A | N/A |
| 1-1/8" | C600-G05 | C600-G06 | N131-1014 | 0.375 | 0.188 | 1.100 | 0.302 | 0.688 | 0.500 | 0.474 | 0.490 | N/A | N/A | N/A | N/A | N/A | N/A | N/A |
| 1-1/2" | C600-K05 | C600-K06 | N131-1000 | 0.750 | 0.375 | 1.500 | 0.424 | 0.813 | 0.625 | 0.438 | 0.438 | 0.625 | 1/4 | 1/4 | 0.250 | 0.625 | 2.875 | 3.375 |
| 2" | C600-L05 | C600-L06 | N131-1000 | 0.750 | 0.375 | 1.500 | 0.424 | 0.938 | 0.750 | 0.438 | 0.438 | 0.625 | 1/4 | 1/4 | 0.250 | 0.750 | 3.375 | 3.875 |
| 2-1/2" | C600-M05 | C600-M06 | N131-1000 | 0.750 | 0.375 | 1.500 | 0.424 | 1.000 | 0.750 | 0.500 | 0.500 | 0.750 | 5/16 | 5/16 | 0.250 | 1.125 | 4.000 | 4.375 |
| 3" | C600-N05 | C600-N06 | N131-1001 | 1.000 | 0.625 | 2.125 | 0.553 | 1.313 | 1.063 | 0.625 | 0.625 | 0.750 | 5/16 | 5/16 | 0.375 | 1.625 | 4.500 | 4.875 |
| 4" | C600-R05 | C600-R06 | N131-1001 | 1.000 | 0.625 | 2.125 | 0.553 | 1.688 | 1.438 | 0.625 | 0.625 | 0.750 | 3/8 | 3/8 | 0.375 | 1.625 | 5.750 | 6.250 |

Accessories Continued

Dimensions: Inches

Rod Clevis - 3/4" and 1 1/8" Bores

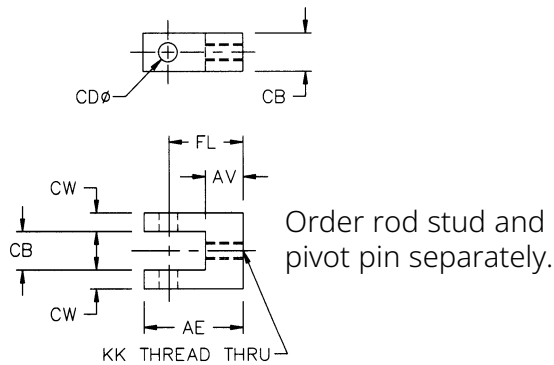

Rod Clevis - 1 1/2" Through 4" Bores

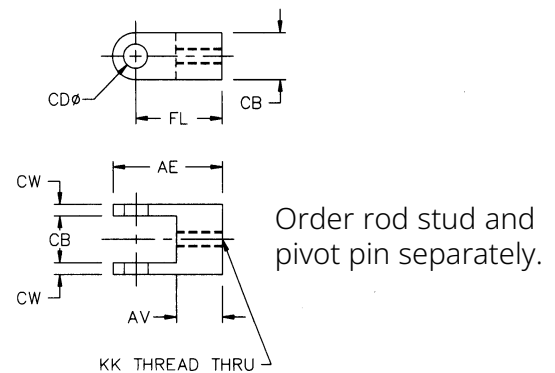

Rod Eye - 3/4" and 1 1/8" Bores

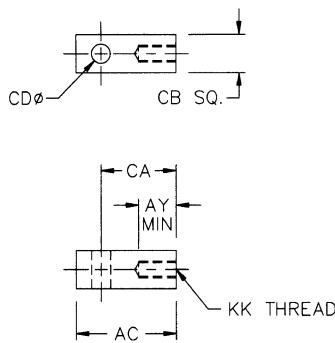

Rod Eye - 1 1/2" Through 4" Bores

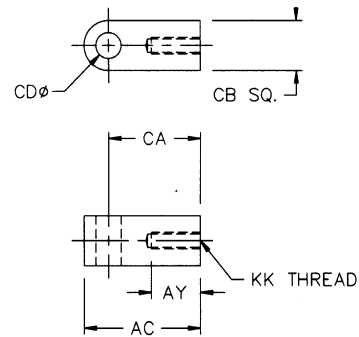

| Bore | Eye | Clevis | AC | AE | AV | AY | AZ | CA | CB | CD | CL | CW | FL | KK |
|--------|----------|----------|-------|-------|-------|-------|-------|-------|-------|-------|-------|-------|-------|---------|
| 3/4" | C500-706 | C500-606 | 0.938 | 0.938 | 0.375 | 0.375 | 0.750 | 0.750 | 0.375 | 0.188 | 0.750 | 0.188 | 0.750 | #8-32 |
| 1-1/8" | C500-708 | C500-608 | 0.938 | 0.938 | 0.375 | 0.375 | 0.750 | 0.750 | 0.375 | 0.188 | 0.750 | 0.188 | 0.750 | 1/4-28 |
| 1-1/2" | C500-701 | C500-601 | 1.093 | 1.375 | 0.600 | 0.375 | 0.875 | 0.718 | 0.750 | 0.375 | 1.125 | 0.188 | 1.000 | 7/16-20 |
| 1-1/2" | C500-702 | C500-602 | 1.093 | 1.375 | 0.600 | 0.375 | 1.125 | 0.718 | 0.750 | 0.375 | 1.125 | 0.188 | 1.000 | 1/2-20 |
| 2" | C500-701 | C500-601 | 1.093 | 1.375 | 0.600 | 0.375 | 0.875 | 0.718 | 0.750 | 0.375 | 1.125 | 0.188 | 1.000 | 7/16-20 |
| 2" | C500-702 | C500-602 | 1.093 | 1.375 | 0.600 | 0.375 | 1.125 | 0.718 | 0.750 | 0.375 | 1.125 | 0.188 | 1.000 | 1/2-20 |
| 2-1/2" | C500-701 | C500-601 | 1.093 | 1.375 | 0.600 | 0.375 | 0.875 | 0.718 | 0.750 | 0.375 | 1.125 | 0.188 | 1.000 | 7/16-20 |
| 2-1/2" | C500-702 | C500-602 | 1.093 | 1.375 | 0.600 | 0.375 | 1.125 | 0.718 | 0.750 | 0.375 | 1.125 | 0.188 | 1.000 | 1/2-20 |
| 3" | C500-703 | C500-603 | 1.500 | 2.188 | 0.750 | 0.500 | 1.375 | 1.000 | 1.000 | 0.625 | 1.500 | 0.250 | 1.688 | 3/4-16 |
| 4" | C500-703 | C500-603 | 1.500 | 2.188 | 0.750 | 0.500 | 1.375 | 1.000 | 1.000 | 0.625 | 1.500 | 0.250 | 1.688 | 3/4-16 |

Accessories Continued
Dimensions: Inches

Rod Stud

Clevis Pins - 3/4" and 1 1/8" Bores

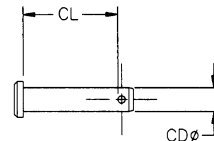
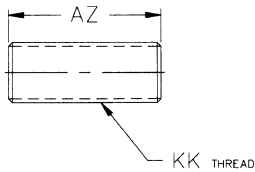

Clevis Pins - 1 1/2" Through 4" Bores

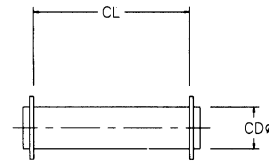

| Bore | Rod Stud | Pivot Pin | AC | AE | AV | AY | AZ | CA | CB | CD | CL | CW | FL | KK |
|--------|----------|-----------|-------|-------|-------|-------|-------|-------|-------|-------|-------|-------|-------|---------|
| 3/4" | C500-506 | C500-406 | 0.938 | 0.938 | 0.375 | 0.375 | 0.750 | 0.750 | 0.375 | 0.188 | 0.750 | 0.188 | 0.750 | #8-32 |
| 1-1/8" | C500-508 | C500-406 | 0.938 | 0.938 | 0.375 | 0.375 | 0.750 | 0.750 | 0.375 | 0.188 | 0.750 | 0.188 | 0.750 | 1/4-28 |
| 1-1/2" | C500-502 | C500-403 | 1.093 | 1.375 | 0.600 | 0.375 | 0.875 | 0.718 | 0.750 | 0.375 | 1.125 | 0.188 | 1.000 | 7/16-20 |
| 1-1/2" | C500-503 | C500-403 | 1.093 | 1.375 | 0.600 | 0.375 | 1.125 | 0.718 | 0.750 | 0.375 | 1.125 | 0.188 | 1.000 | 1/2-20 |
| 2" | C500-502 | C500-403 | 1.093 | 1.375 | 0.600 | 0.375 | 0.875 | 0.718 | 0.750 | 0.375 | 1.125 | 0.188 | 1.000 | 7/16-20 |
| 2" | C500-503 | C500-403 | 1.093 | 1.375 | 0.600 | 0.375 | 1.125 | 0.718 | 0.750 | 0.375 | 1.125 | 0.188 | 1.000 | 1/2-20 |
| 2-1/2" | C500-502 | C500-403 | 1.093 | 1.375 | 0.600 | 0.375 | 0.875 | 0.718 | 0.750 | 0.375 | 1.125 | 0.188 | 1.000 | 7/16-20 |
| 2-1/2" | C500-503 | C500-403 | 1.093 | 1.375 | 0.600 | 0.375 | 1.125 | 0.718 | 0.750 | 0.375 | 1.125 | 0.188 | 1.000 | 1/2-20 |
| 3" | C500-505 | C500-404 | 1.500 | 2.188 | 0.750 | 0.500 | 1.375 | 1.000 | 1.000 | 0.625 | 1.500 | 0.250 | 1.688 | 3/4-16 |
| 4" | C500-505 | C500-404 | 1.500 | 2.188 | 0.750 | 0.500 | 1.375 | 1.000 | 1.000 | 0.625 | 1.500 | 0.250 | 1.688 | 3/4-16 |

C series World application Detail

Round Tube and Tie Rod Detail

1. World Switch
2. Tie Rod Bracket
3. Cylinder Tie Rod

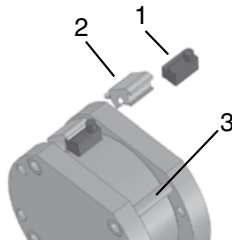

Profile Tube Detail

1. World Switch
2. Dove Tail extrusion

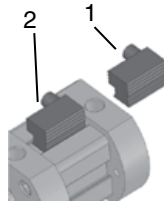

C series World Switch Bracket

| Cylinders | Bore | Part Number |
|------------------|-------------|-------------|
| C series Profile | 3/4"-2 1/2" | Direct Fit |
| C series Tie Rod | 3" Bore | SB6-L01 |
| C series Tie Rod | 4" Bore | SB6-P01 |

C Series World Switch Hall Effect Part Numbers

| P/N | Switch Style | Electrical Design | Output | Operating Voltage | Current Rating | Switching Power | Voltage Drop | NEMA IP Rating | Temperature Rating |
|---------|--------------|-------------------|---------------|-------------------|----------------|-----------------|--------------|----------------|--------------------|
| SH6-031 | Flying Lead | PNP | Normally Open | 6 -24 VDC | 0.3 Amps Max. | 7.2 Watts Max. | 0.5 Volts | NEMA 6 | -25° to +75° C |
| SH6-032 | Flying Lead | NPN | Normally Open | 6 -24 VDC | 0.3 Amps Max. | 7.2 Watts Max. | 0.5 Volts | NEMA 6 | -25° to +75° C |
| SH6-021 | M8 Connector | PNP | Normally Open | 6 -24 VDC | 0.3 Amps Max. | 7.2 Watts Max. | 0.5 Volts | NEMA 6 | -25° to +75° C |
| SH6-022 | M8 Connector | NPN | Normally Open | 6 -24 VDC | 0.3 Amps Max. | 7.2 Watts Max. | 0.5 Volts | NEMA 6 | -25° to +75° C |

Hall Effect Switch

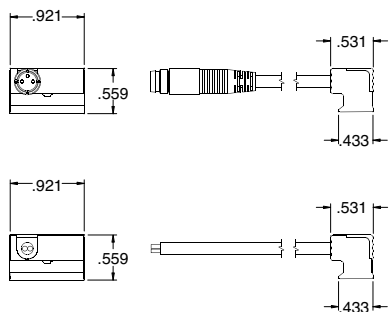

PNP Sourcing

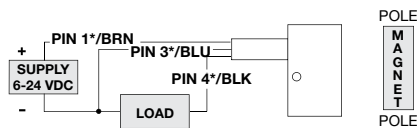

NPN Sinking

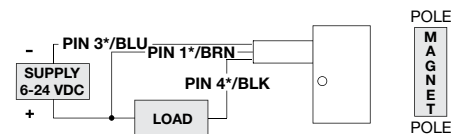

C Series World Switch Reed Switch Part Numbers

| P/N | Switch Style | Electrical Design | Output | Operating Voltage | Current Rating | Switching Power | Voltage Drop | NEMA IP Rating | Temperature Rating |
|---------|--------------|-------------------|---------------|----------------------|------------------------------------|-----------------|--------------|----------------|--------------------|
| SR6-002 | Flying Lead | AC/DC REED | Normally Open | 5-120 VAC/DC | 0.025 Amps Max. 0.001 Amps Min. | 3 Watts Max. | 3.5 Volts | NEMA 6 | -25° to +75° C |
| SR6-004 | Flying Lead | AC/DC REED | Normally Open | 5-120 VAC/DC | 0.5 Amps Max. 0.005 Amps Min. | 10 Watts Max. | 3.0 Volts | NEMA 6 | -25° to +75° C |
| SR6-022 | M8 Connector | AC/DC REED | Normally Open | 5-50 VAC 5-60 VDC | 0.025 Amps Max. 0.001 Amps Min. | 12 Watts Max. | 0.5 Volts | NEMA 6 | -25° to +75° C |
| SR6-024 | M8 Connector | AC/DC REED | Normally Open | 5-50 VAC 5-60 VDC | 0.5 Amps Max. 0.005 Amps Min. | 10 Watts Max. | 3.0 Volts | NEMA 6 | -25° to +75° C |

Reed Switch - Normally Open Type SR6

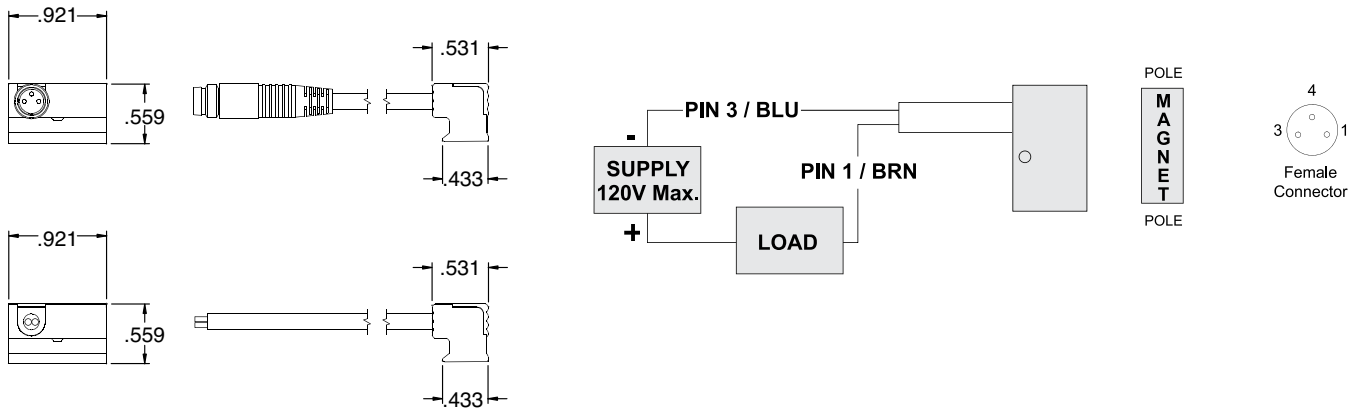

Cords M8-thread for Switches and Sensors with Connector
Dimensions: Inches

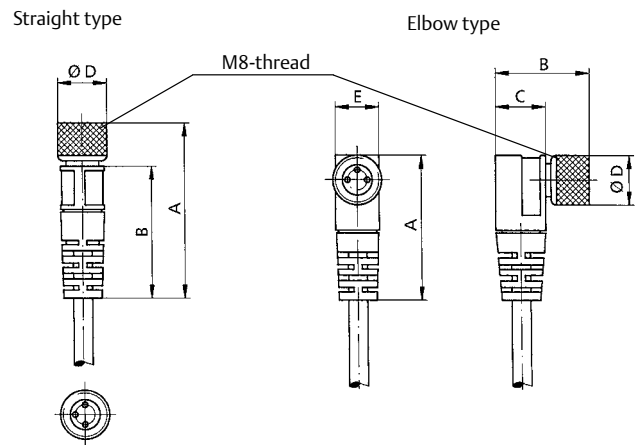

| Type | | A | B | C | D | E | Weight (approx. kg) | Order Code |
|------------------------|---------------------------|------|------|-----|-----|-----|---------------------|------------|
| Straight with 5m-cable | (3x0.25 mm ²) | 32.3 | 24.4 | — | 9.0 | — | 0.143 | PXCST |
| Elbow with 5m-cable | (3x0.25 mm ²) | 26.3 | 17.1 | 9.2 | 9.0 | 8.0 | 0.145 | PXC90 |

Compact Cylinders

C Series (Profile Tube) 2 in magnet code

| Bore | Bracket P/N |
|--------|-----------------|
| 3/4" | P4994406190N001 |
| 1 1/8" | P4994406190N001 |
| 1 1/2" | P4994406190N001 |
| 2" | P4994406190N001 |
| 2 1/2" | P4994406190N001 |



| Sensor Description | Standard Cord Set | Quick Disconnect |
|--------------------|-------------------|------------------|
| Reed Switch | P494A0021300A00 | P494A0021600A00 |
| Hall PNP | P494A0022300A00 | P494A0022600A00 |
| Hall NPN | P494A0022400A00 | P494A0022700A00 |

C Series (Tie Rod) 2 in magnet code

| Bore | Bracket P/N |
|------|-----------------|
| 3" | P4995051670N001 |
| 4" | P499440617MN001 |



| Sensor Description | Standard Cord Set | Quick Disconnect |
|--------------------|-------------------|------------------|
| Reed Switch | P494A0021300A00 | P494A0021600A00 |
| Hall PNP | P494A0022300A00 | P494A0022600A00 |
| Hall NPN | P494A0022400A00 | P494A0022700A00 |

How to Order - C Series Piston Rod Assembly

C92 - K 3 1 A 0 - 01 A - AA

Type _____
C92 = C Series Piston Rod Assembly

Bore _____
C = 3/4"
G = 1-1/8"
K = 1-1/2"
L = 2"
M = 2-1/2"
N = 3"
R = 4"

Rod Code _____
1 = #1 Standard Rod Diameter
2 = #2 Standard Rod Diameter
3 = #3 Standard Rod Diameter
*4 = Special Rod End Standard Rod Diameter (must specify threads)
*5 = Special Rod End Standard Rod Diameter (must specify threads)
6 = Style #1 Oversize Rod Diameter
8 = Style #3 Oversize Rod Diameter

Mount _____
1 = All Mounts Except F1 & R1
2 = F1 Mount
3 = R1 Mount

Port _____
A = All Port Sizes Other Than 1/8"
B = 1/8" Ports

Magnet Piston _____
0 = no magnet
2 = Reed Magnet and Wear Band

Options
AA = No options
BC = Bumpered Cap End
BH = Bumpered Head End
DA = Double Rod
NA = Nickel Plated
SA = Stainless Rod
VA = FKM Seals
WA = Wearband
*1A = Rod Extension
*1B = Rear Rod Extension
*2B = Rear Thread Extension
3A = Rod Stud
3B = Rear Rod Stud
*4A = Stop Tube
* Must specify length

Fractional Inches of Stroke
A = 0" I = 1/2"
B = 1/16" J = 9/16"
C = 1/8" K = 5/8"
D = 3/16" L = 11/16"
E = 1/4" M = 3/4"
F = 5/16" N = 13/16"
G = 3/8" O = 7/8"
H = 7/16" P = 15/16"
Note: 1/8" minimum stroke.

Full Inch of Stroke
00 = 0" Stroke
01 = 1" Stroke
02 = 2" Stroke
03 = 3" Stroke
04 = 4" Stroke
20 = 20" Stroke (Maximum)

Note: Options listed are ones that apply to a piston rod assembly only.
Model number is set up to use option code supplied with original cylinder or with any above.

Rod End Styles, Diameters and Threads

| Type | Diameter | Style #1 Optional Male | Style #2 Optional Female | Style #3 Standard Female |
|--------|----------|---------------------------|-----------------------------|-----------------------------|
| 3/4" | 0.250 | #8-32 | N/A | #8-32 |
| 1 1/8" | 0.500 | 1/4-28 | 5/16-24 | 1/4-28 |
| 1 1/2" | 0.625 | 7/16-20 | 3/8-24 | 7/16-20 |
| | 0.750 | 1/2-20 | N/A | 1/2-20 |
| 2" | 0.625 | 7/16-20 | N/A | 7/16-20 |
| | 0.750 | 1/2-20 | N/A | 1/2-20 |
| 2 1/2" | 0.625 | 7/16-20 | N/A | 7/16-20 |
| | 0.750 | 1/2-20 | N/A | 1/2-20 |
| 3" | 1.000 | 3/4-16 | 5/8-18 | 3/4-16 |
| 4" | 1.000 | 3/4-16 | N/A | 3/4-16 |

How to Order - C Series Repair Kit

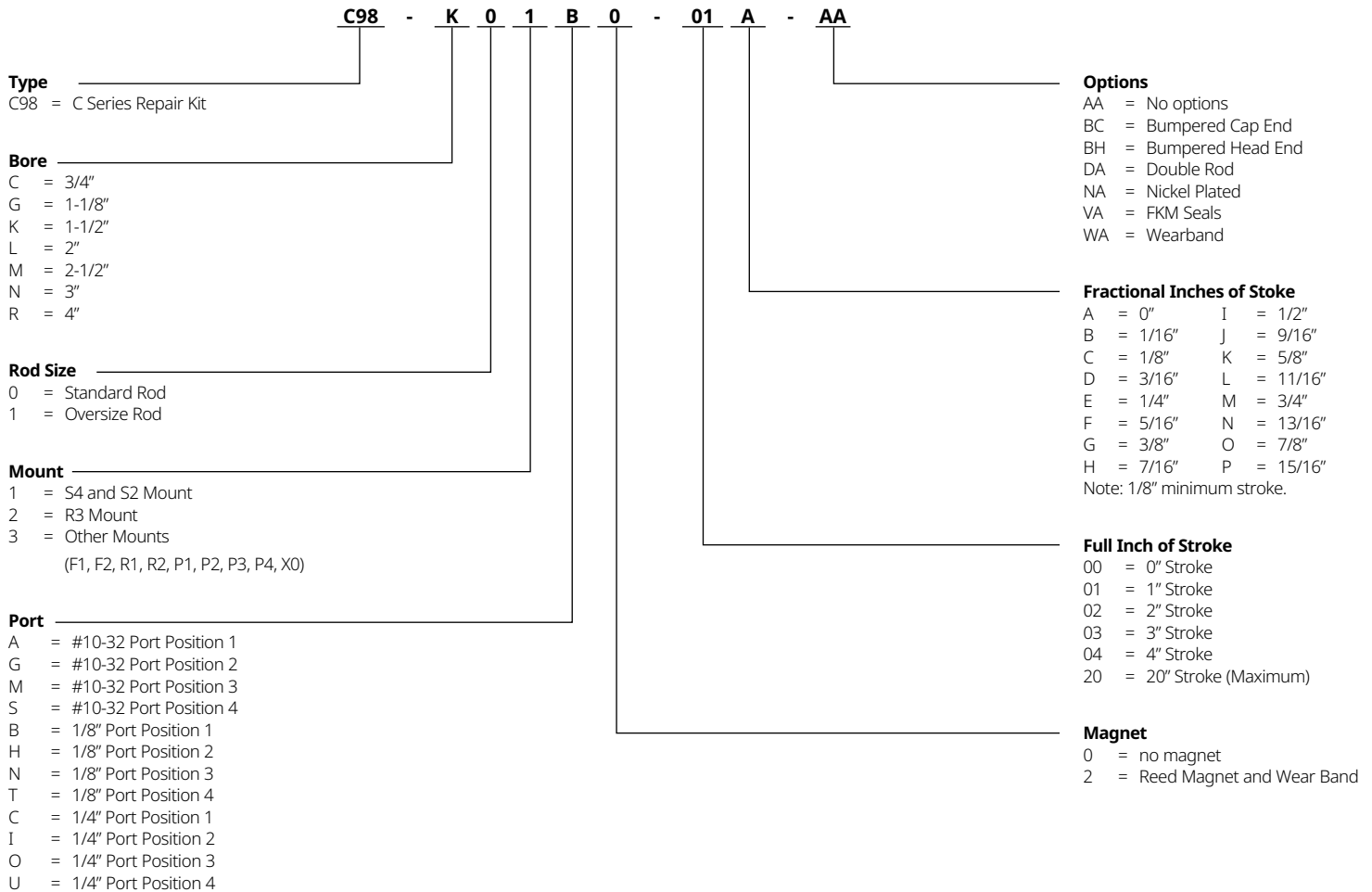

Note: Options listed are ones that apply to repair kit only.
Model number is set up to use option code supplied with original cylinder or with any above.

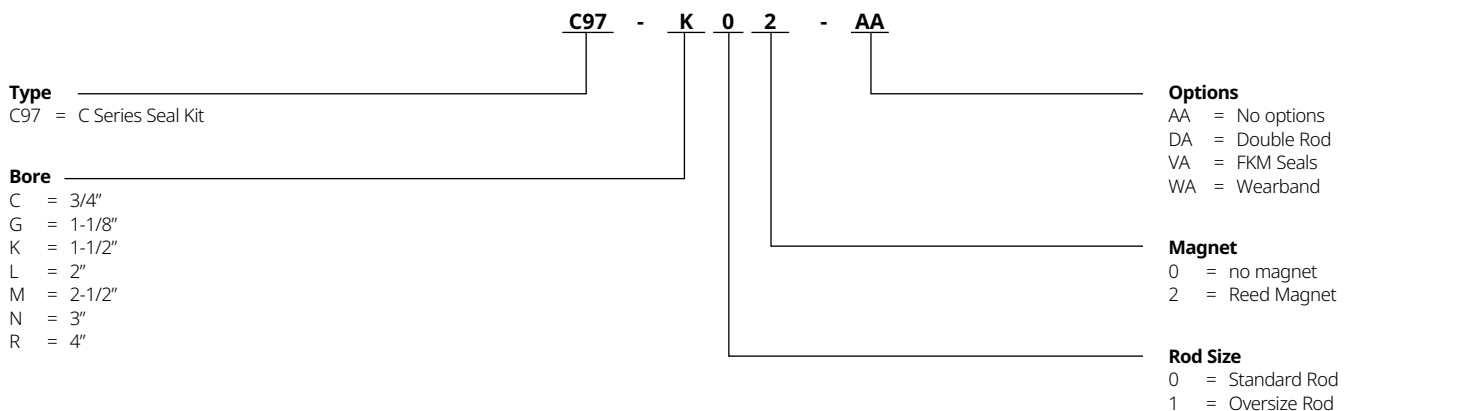

Note: Options listed are ones that apply to seal kit only.
Model number is set up to use option code supplied with original cylinder or with any above.

Note:
Tie Rod and Sleeve Nuts are Standard on 3" and 4" bore sizes.