



**Reliable fluid power for the most demanding applications.**

**AVENTICS™ NFPA Steel Cylinders**  
PowerMaster® Pneumatic & Hydraulic (PPT/PHT)  
PressureMaster® Hydraulic (HHT)



## AVENTICS™ Series PowerMaster NFPA cylinders

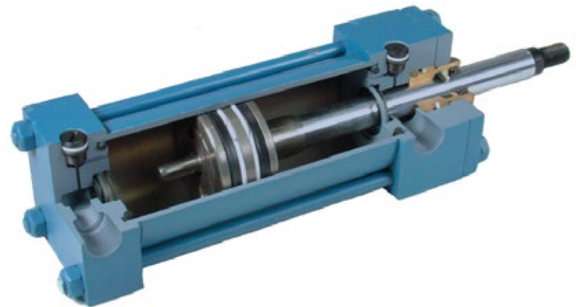
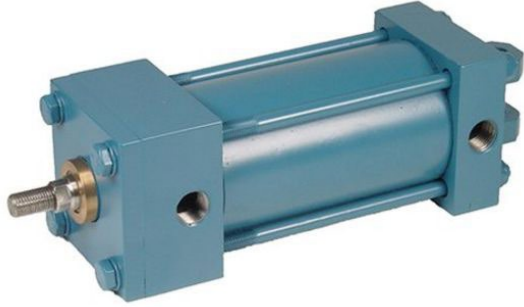

PPT Pneumatic (to 250 psi, 1 1/2" - 14" Bores standard)  
PHT Hydraulic (to 1500 psi, 1 1/2" - 14" Bores standard)

## AVENTICS™ Series PressureMaster NFPA cylinders

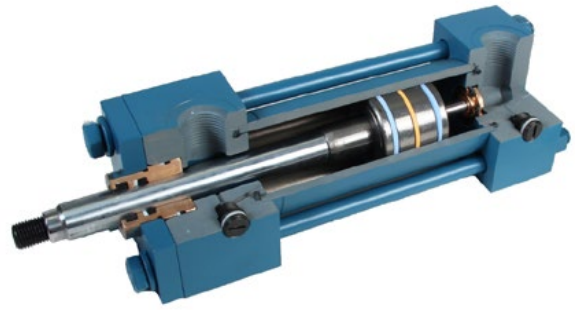

HHT Hydraulic (to 3000 psi nominal, 5000 psi non-shock; 1 1/2" - 14" Bores standard)

## Custom cylinders and extensive range of options



- Cylinders with or prepared for proximity switches for end of stroke position sensing



- Transducer ready or installed option with valve mounting patterns also available



- Custom materials, porting, rod ends, mounts, corrosion protection, etc.

To find, configure and order your NFPA cylinder, please visit [Emerson.com/AVENTICS](https://www.emerson.com/AVENTICS)

# Table of Contents

## **PowerMaster® NFPA PPT Air Cylinder (to 250 psi) & PHT Hydraulic Cylinder (to 1500 psi)**

---

**Machine Tool Grade, Steel Head & Tube/Tie Rod Construction, Removable Rod Cartridge,  
23 Standard Mountings, Cushioning, Wide Selection of Options, Modifications & Accessories**

Features & Specifications .....	5
Options & Modifications .....	7
Mounting Style Index .....	10
Mounting Style & Dimensional Data—1 1/2" thru 14" Bore .....	11
How To Order .....	25
Service Information .....	26
Rod End Options & Standard Porting .....	72
Accessories .....	73 - 74

## **PressureMaster® NFPA HHT High Pressure Hydraulic Cylinders – 3000 psi Nominal/5000 psi Non-Shock**

---

**Machine Tool Grade, Steel Head & Tube/Tie Rod Construction, Removable Rod Cartridge,  
22 Standard Mountings, Cushioning, Wide Selection of Options, Modifications & Accessories**

Features & Specifications .....	33
Options & Modifications .....	35
Integral Position Feedback (Transducer Ready or Installed) .....	39
Mounting Style Index .....	40
Mounting Style & Dimensional Data .....	41
How To Order .....	55
Service Information .....	56
Rod End Options & Standard Porting .....	72
Accessories.....	73 - 74

## **Application Data – All Cylinders**

---

Sizing - Force & Displacement Table .....	60
Mounting Considerations .....	64
Stop Tube Calculations & Column Strength/Oversize Rod Selection .....	67
Cylinder Specifications Sheet .....	70



**PPT PNEUMATIC & PHT HYDRAULIC CYLINDERS**

**UP TO 1500 PSI**

**1-1/2" — 14" BORE**

**MACHINE TOOL GRADE NFPA DESIGNS**



# Heavy Duty Pneumatic and Hydraulic NFPA Steel Cylinders

## POWERMASTER® PPT PNEUMATIC & PHT HYDRAULIC CYLINDERS

### STANDARD CYLINDER SPECIFICATIONS

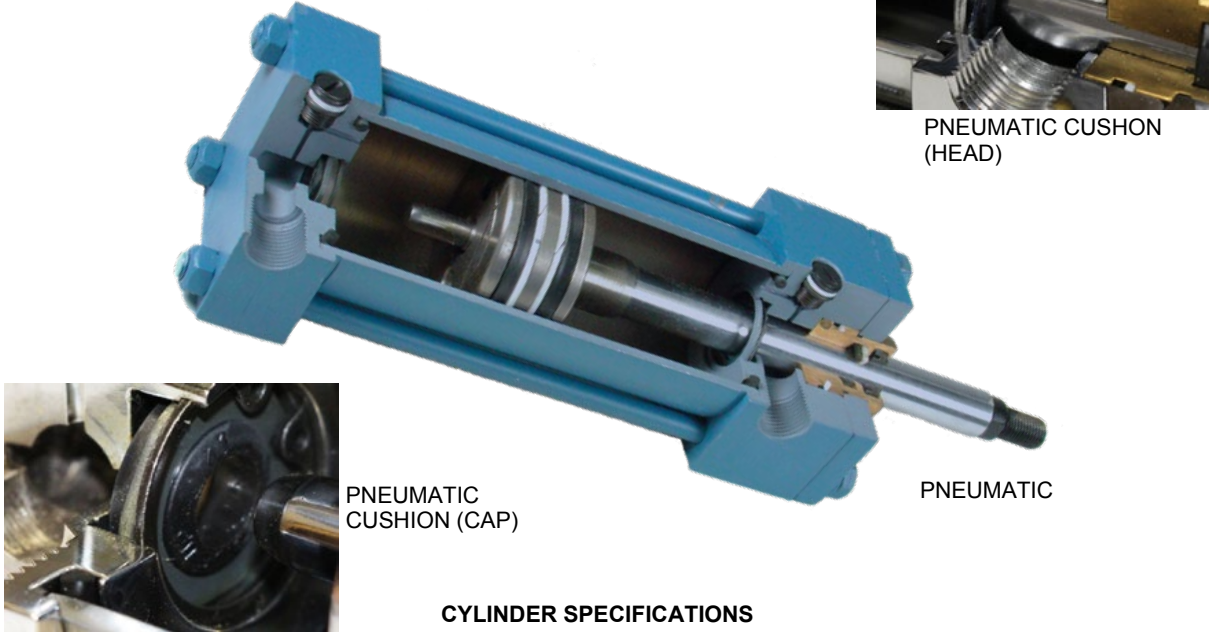

#### OPERATING PRESSURES BY CYLINDER BORE SIZES

(Max. PSI, Max. Duty Severe Service)

Bore Size	PHT-Hyd.	PPT-Air
1 1/2	1500§	250
2	1500§	250
2 1/2	1500*§	250
3 1/4	1500§	250
4	1000	250
5	750	250
6	750	250
8	500	250
10	400	250
12	250	250
14	250	250

\*With 5/8" rod, 1000 psi.  
§ MF1 & MF2 Maximum Operating Pressure is 1000 psi.

For Double rod end cylinder pressure ratings, see page 25.

Consult factory for specific applications at pressures higher than shown

#### CYLINDER SPECIFICATIONS

- Duty**– 250 psi pneumatic PP, pre-lubricated.  
250 to 1500 psi hydraulic PH
- Standards**– Meets or exceeds all J. I. C. and NFPA requirements.
- Bore Sizes**– 1-1/2" -14" (standard), larger available.
- Piston Rods**– 5/8" -5-1/2" (standard)
- Mounting**– 21 standard NFPA mountings.
- Temperature**  
**Range**– Standard Buna-N seals: -65°F to +200°F  
Optional Viton® seals -15°F to +400°F  
(Consult factory for cylinder applications at extreme temperatures.)
- Ports**– NPTF dryseal tapered threads. Optional SAE straight thread ports available. (Flange ports available at extra cost.)
- Stroke**– Standard strokes furnished to nearest 1/8". Normal stroke tolerance +/- 1/16". Closer stroke tolerance available; consult factory.
- Rod End Threads**– Standard KK1 male and female threads plus KK2 oversize male thread. Other rod end style optional.
- Cushions**– Available for all bore sizes, at either or both ends.
- Piston Rods**– Case hardened to 50-55 Rockwell "C" chrome-plated and finished to 15 microinches or better. (5/8" not case hardened)
- Tie Rods**– High tensile, 1144 stress proof steel
- Cylinder Tube**– Honed, steel tubing with chrome plated I.D.
- Double End Rod**– Available in many mounting styles to meet special needs.

# Heavy Duty Pneumatic and Hydraulic NFPA Steel Cylinders

## POWERMASTER® PPT PNEUMATIC & PHT HYDRAULIC CYLINDERS

### CYLINDER SPECIFICATIONS

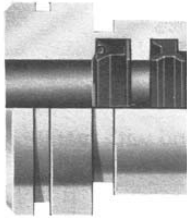

Extra-long rod bearing provides for maximum support against side-loads including external misalignment. Marine-grade 660 bronze material has superior non-scoring properties and dimensional stability. Bearing is pilot fitted into the head assuring true concentricity and long bearing and seal life. Cartridge can be quickly and easily changed without special tools. Ductile iron is used in large bores with certain rod diameters.



Pressure energized rod seal provides positive sealing with minimum friction drag. Self-adjusting seal in the Powermaster Pneumatic and U-cup/O-ring in the Powermaster Hydraulic coordinate operating pressures with sealing forces.

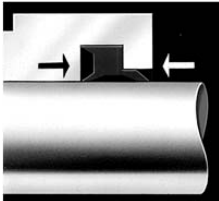

Double Duty Twin Lip rod wiper provides dirt protection for the rod bearing and rod seal. External lip prevents entry of contaminants into the bearing area on in-stroke, and internal lip wipes rod on outstroke and serves as secondary seal. The standard materials are polyurethane, Buna-N and Viton®. A metallic wiper is offered as an option (5/8" — 3" rod).

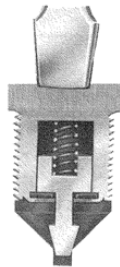

Powermaster's self-aligning cushion design provides a positive sealing leakproof cushion with fast piston breakaway. The Powermaster Pneumatic cushioning consists of a "floating" cushion insert seal on both ends and the Powermaster Hydraulic has floating cushion bushing on the rod end with a floating metal insert seal on the cap end. This design provides for a maximum cushion effect with faster breakaway response.

The AVENTICS Exact-a-just™ combination needle and check valve eliminates the need for separate ball checks (thus leaving a quadrant free for other possible use).

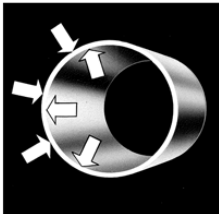

Dent and corrosion resistant tubing. Steel tubing is honed to a 12 micro-inch, or better, finish, then chrome-plated for minimum friction and long seal life. (Chrome-plated I.D. tubing furnished for Powermaster Pneumatic).



Pressure energized U-cup piston seals provide positive sealing with minimum friction. Standard Buna-N has an operating range of -65°F to +200°F with Viton available for high temperatures -15°F to +400°F.

# Heavy Duty Pneumatic and Hydraulic NFPA Steel Cylinders

## POWERMASTER® PPT PNEUMATIC & PHT HYDRAULIC CYLINDERS

### CYLINDER OPTIONS

#### VITON SEALS

Available for high temperature air service in a temperature range of -15°F to 400°F, and with many special hydraulic fluids. (Special fluids should be checked for compatibility with Viton.)

#### PISTON ROD OPTIONS

Non-standard rod ends are available including rod and thread extensions, special threads and rod end machining, and additional wrench flats. (Catalog dimensional changes must be specified.)  
Optional rod materials for specific applications and environmental conditions which includes 303 and 17- 4 PH stainless steel.

#### METALLIC ROD WIPER

Metal scraper available for the removal of tough/hardened matter adhering to piston rod. (Rod boots for exterior rod protection might also be considered.)

#### PORT OPTIONS

SAE straight thread ports are optional at no additional charge. Other standard size ports, oversize welded coupling ports and multiple ports are also available where design dimensions permit.

#### STOP TUBE

Internal stop tube is available for reducing excessive bearing loads and jackknifing conditions in long stroke push cylinders. (See page 68 for determining stop tube length required.)

#### COMBINATION MOUNTING

Additional cylinder mountings are available where design space permits.

#### WATER SERVICE

Model PW is available for water service and includes: electroless nickel plated head, cap, piston, and cushion parts when applicable. Standard Powermaster tube provides chrome-plated I.D. at no additional charge. Stainless steel piston rod is also recommended.

#### EPOXY PAINT

Available for additional exterior cylinder protection in corrosive environments. Painting includes one coat of Yellow Zinc Chromate Primer and one coat of Black Epoxy Enamel.

#### TAPPED RETAINER PLATE

Head retainer plate tapped for tie rods available when bolts or tie rod nuts are not permitted on head end. (Available for 1-1/2" — 6" bore sizes).

#### EXTRA CHECK VALVE

Available for faster breakaway response for cushioned cylinders.

#### CUSHIONS (Exact-a-just™)

Available for head, cap or both

CONSULT FACTORY FOR OTHER OPTION REQUIREMENTS NOT SHOWN IN THIS CATALOG.

### APPROXIMATE UNCRATED POWERMASTER WEIGHTS\*

CYLINDER BORE	1-1/2	2	2-1/2	3-1/4	4	5	6	8	10	12	14
ZERO STROKE	5	7	12	20	30	45	70	100	200	300	490
ADD PER INCH OF STROKE	.3	.4	.6	.8	.9	1.0	1.5	2.0	2.5	4.0	4.5

\*Weights based on standard (first) rod sizes.

# Heavy Duty Pneumatic and Hydraulic NFPA Steel Cylinders

## POWERMASTER® PPT PNEUMATIC & PHT HYDRAULIC CYLINDERS

### CYLINDER OPTIONS

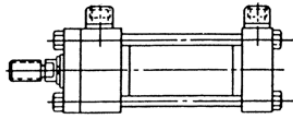

Oversize welded coupling ports are available where design and mounting dimensions permit. (Available on head end only in smaller bore sizes due to limited design space and mounting interference).

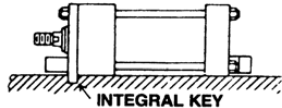

Emerson offers a standard arrangement of thrust key mounting on the MS2, MS4 and MS7 Powermaster cylinders. This options eliminates the need for fitted bolts or external keys to carry the thrust load. The normal headplate is extended below the head surface of the cylinder and is fitted in a keyway milled into the mounting surface of the machine member. See drawings for details.

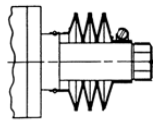

Rod boots are available for additional rod protection from environmental conditions. The oil resistant cover of neoprene-coated nylon fabric is suitable for operation in ambient temperature range of -45°F to 220°F. Consult factory for higher temperature boot requirements.

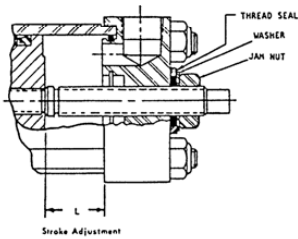

Stroke adjustment option is available for applications requiring a precise stroke or when infrequent stroke length adjustment is required in the retracted position. Maximum stroke adjustment varies by bore size and must be specified when ordering. Cushioning is not available on the cap end with this design.

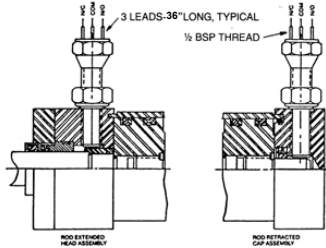

#### POSITION INDICATOR

Proximity Position Indicator Switches are available for most mounting styles and rod sizes of Powermaster cylinders. These switches are mounted in the head and cap ends to confirm the extended or retracted position of the piston. The switches are actuated by the cushion bushing on the head end and the cushion spear on the cap end. (NOTE: If cap cushioning is required in the 1-1/2", 2" and 2-1/2" bore PP and PH Powermaster cylinder, proximity switches cannot be used on the cap end.) No linkage or external actuator is required. Switches can be assembled in the cylinder head, cap, or rear cap face. The switches are not sensitive to vibration and are suitable for most environments. Switch height is less than four inches; for critical dimensions, contact factory.

Upon request, we can supply most name brand switches, such as Balluff Strokemaster, P & F low profile, Stroke to Go low profile, NAMCO and others.

#### SENSING DISTANCE

End sensing of .090" (2.25mm) to .110" (2.76mm) when using a ferrous actuator approximately equal the area of the end. The differential (hysteresis) is approximately 1/2 of the sensing range. The GO® Switch is not a "reed switch".

#### CONTACT RATING

2AMP at 240 VAC (CSA and UL approved)  
50mA at 24 VDC (CSA only)

#### CONTACT ARRANGEMENT

Available in Single Pole, Double Throw.

#### TEMPERATURE RANGE

Tested to -22°F to +250°F. Impervious to most environments. Recognized by UL at 104°F (40°C) maximum.

#### CAUTION

THESE UNITS ARE **NOT** INTENDED TO BE USED AS A FINAL SAFETY DEVICE

GO® is a trademark of General Equipment Manufacturing Company, Inc.



# Heavy Duty Pneumatic and Hydraulic NFPA Steel Cylinders

## POWERMASTER® PPT PNEUMATIC & PHT HYDRAULIC CYLINDERS

### EXTENDED KEY PLATE

Emerson offers a standard arrangement of thrust key mounting on the MS2, MS4 and MS7 PowerMaster cylinders. This option eliminates the need for fitted bolts or external keys to carry the thrust load. The normal headplate is extended below the head surface of the cylinder and is fitted in a keyway milled into the mounting surface of the machine member. See drawings for details.

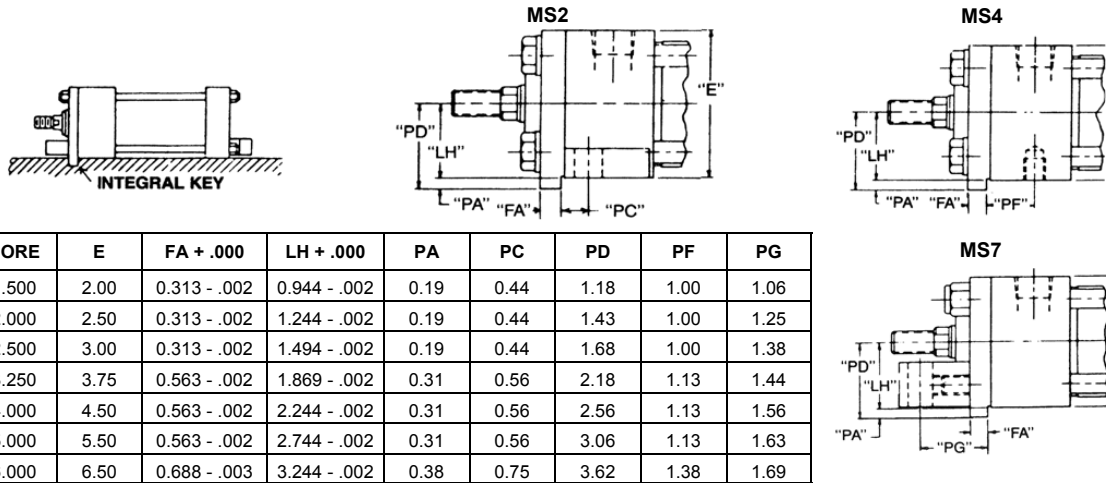

**NOTE:**

1. Use mounting bolt .06 smaller in diameter than hole size.
2. Fitted bolts or dowel pins are not needed with the trust key headplate.
3. All dimensions not shown are NFPA standard.

## POWERMASTER® PHT & HHT HYDRAULIC CYLINDERS

### AVAILABLE PORTS FOR "PHT" SERIES CYLINDERS

BORE SIZE (inches)	SAE	NPTF PIPE THD	BSPP PARALLEL THD	BSPT TAPER THD	METRIC STRAIGHT THD	ISO 6149-1 METRIC THD
1	#4	1/4	1/4	1/4	M14 X 1.5	-
1.5	#6	3/8	3/8	3/8	M14 X 1.5	-
2	#6	3/8	3/8	3/8	M14 X 1.5	M14 X 1.5
2.5	#6	3/8	3/8	3/8	M14 X 1.5	M14 X 1.5
3.25	#8	1/2	3/8	3/8	M22 X 1.5	M22 X 1.5
4	#8	1/2	1/2	1/2	M22 X 1.5	M22 X 1.5
5	#8	1/2	1/2	1/2	M22 X 1.5	M22 X 1.5
6	#12	3/4	1/2	1/2	M26 X 1.5	M27 X 1.5

### AVAILABLE PORTS FOR "HHT" SERIES CYLINDERS

BORE SIZE (inches)	SAE	NPTF PIPE THD	BSPP PARALLEL THD	SAE 4-BOLT FLANGE NOM. SIZE	BSPT TAPER THD	METRIC STRAIGHT THD	ISO 6149-1 METRIC THD
1.5	#8	1/2	1/2	n/a	1/2	M22 X 1.5	M22 X 1.5
2	#8	1/2	1/2	* 1/2	1/2	M22 X 1.5	M22 X 1.5
2.5	#8	1/2	1/2	* 1/2	1/2	M22 X 1.5	M22 X 1.5
3.25	#12	3/4	3/4	** 1/2	3/4	M27 X 2	M27 X 2
4	#12	3/4	3/4	1/2	3/4	M27 X 2	M27 X 2
5	#12	3/4	3/4	*** 1/2	3/4	M27 X 2	M27 X 2
6	#16	1	1	§ 3/4	1	M33 X 2	M33 X 2
7	#20	1-1/4	1-1/4	§ 1	1-1/4	M42 X 2	M42 X 2
8	#24	1-1/4	1-1/2	§ 1-1/4	1-1/2	M48 X 2	M48 X 2

§ Size 1/2" on 6" bore (4" rod) and 7" bore (5" rod);  
 Size 1" on 8" bore (5-1/2" rod).

\*Cap only

\*\*Not available on 3-1/4" bore (2" rod).

\*\*\*Not available on 5" bore (3-1/2" rod).

# Heavy Duty Pneumatic and Hydraulic NFPA Steel Cylinders

## POWERMASTER® PPT PNEUMATIC & PHT HYDRAULIC CYLINDERS

### MOUNTING INDEX

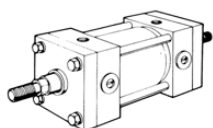
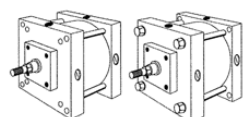
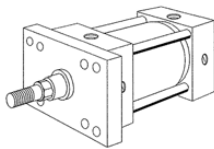
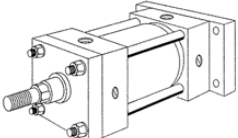
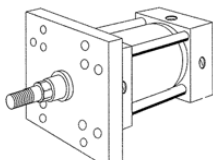
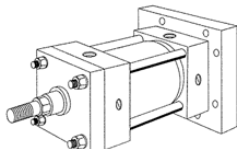
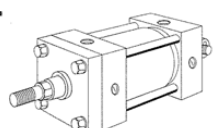
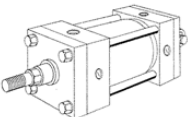
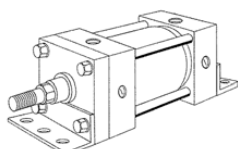
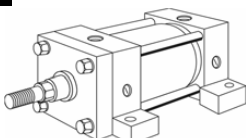
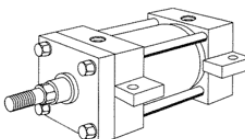
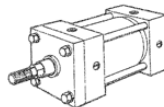
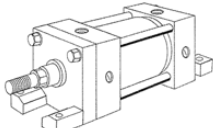
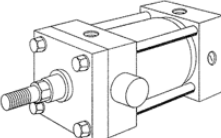
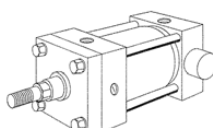
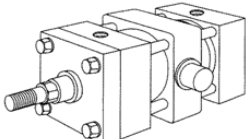
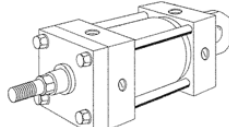
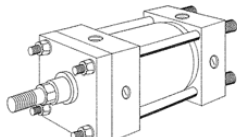
<p><b>D</b> DOUBLE ROD CYLINDER Bore sizes 1-1/2"–6" ..... page 11 Bore sizes 8"–14"</p> 	<p><b>ME3</b> HEAD SQUARE FLANGE Bore sizes 8"–14" ..... page 11</p> <p><b>ME4</b> CAP SQUARE FLANGE Bore sizes 8"–14" ..... page 11</p> 	<p><b>MF1</b> HEAD RECTANGULAR FLANGE Bore sizes 1-1/2"–6" ..... page 13</p> 
<p><b>MF2</b> CAP RECTANGULAR FLANGE Bore sizes 1-1/2"–6" ..... page 13</p> 	<p><b>MF5</b> HEAD SQUARE FLANGE Bore sizes 1-1/2"–6" ..... page 13</p> 	<p><b>MF6</b> CAP SQUARE FLANGE Bore sizes 1-1/2"–6" ..... page 13</p> 
<p><b>MP1</b> CAP FIXED CLEVIS Bore sizes 1-1/2"–14" .....page 15</p>	<p><b>MP2</b> CAP DETACHABLE CLEVIS Bore sizes 1-1/2"–8" ..... page 15</p>	<p><b>MS1</b> SIDE END ANGLES Bore sizes 1-1/2"–6" ..... page 17 Bore sizes 8"–14"</p>
<p><b>MP3</b> CAP FIXED EYE Bore sizes 1-1/2"–14" .....page 15</p> 	<p><b>MP4</b> CAP DETACHABLE EYE Bore sizes 1-1/2"–8" ..... page 15</p> 	
<p><b>MS2</b> SIDE LUGS Bore sizes 1-1/2"–6" .....page 19</p> 	<p><b>MS3</b> CENTERLINE LUGS Bore sizes 1-1/2"–6" ..... page 19 Bore sizes 8"–14"</p> 	<p><b>MS4</b> SIDE TAPPED Bore sizes 1-1/2"–14" .....page 19</p> <p><b>MX0</b> NO MOUNTINGS Bore sizes 1-1/2"–14" .....page 19</p> 
<p><b>MS7</b> SIDE END LUGS Bore sizes 1-1/2"–6" .....page 17 Bore sizes 8"–14"</p> 	<p><b>MT1</b> HEAD TRUNNION Bore sizes 1-1/2"–6" ..... page 21</p> 	<p><b>MT2</b> CAP TRUNNION Bore sizes 1-1/2"–6" ..... page 21 Bore sizes 8"–14"</p> 
<p><b>MT4</b> INTERMEDIATE FIXED TRUNNION Bore sizes 1-1/2"–6" .....page 21 Bore sizes 8"–14"</p> 	<p><b>MU3</b> UNIVERSAL CLEVIS Bore sizes 1-1/2"–6" ..... page 15</p> 	<p><b>MX1</b> TIE ROD EXTENDED Bore sizes 1-1/2"–6" ..... page 23 Bore sizes 8"–14"</p> <p><b>MX2</b></p> <p><b>MX3</b></p> <p><b>MX4</b></p> 

# Heavy Duty Pneumatic and Hydraulic NFPA Steel Cylinders

POWERMASTER® PPT PNEUMATIC & PHT HYDRAULIC CYLINDERS

## DOUBLE ROD CYLINDER HEAD SQUARE FLANGE MOUNT CAP SQUARE FLANGE MOUNT

### D DOUBLE ROD CYLINDER 1-1/2" - 4"

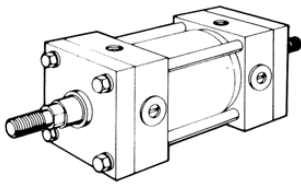

\*8" - 14" Bores only  
\*\*1-1/2" - 6" Bores only

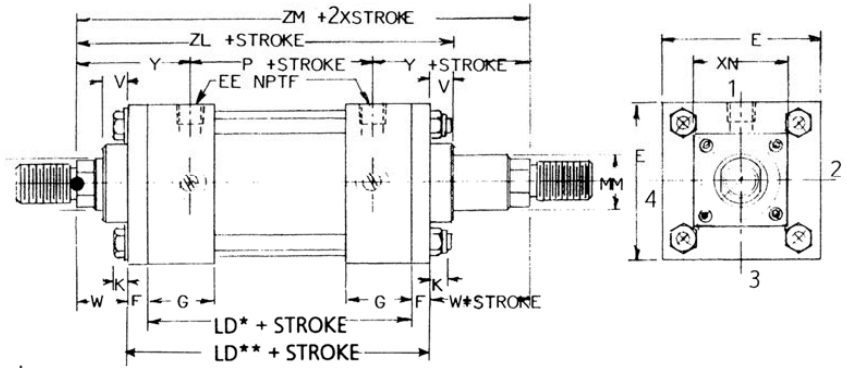

### ME3 HEAD SQUARE FLANGE 8" - 14"

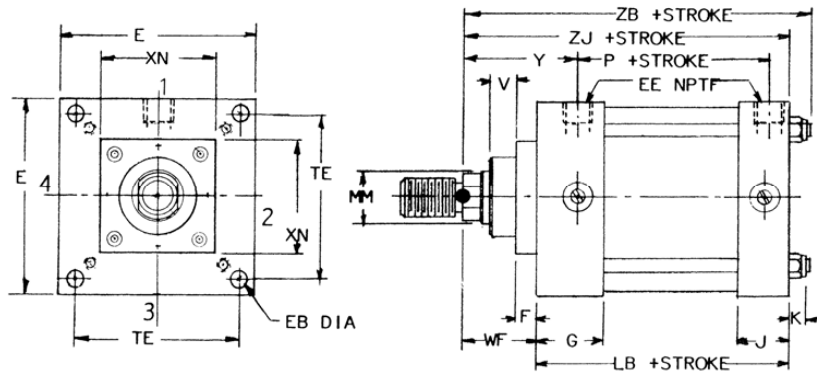
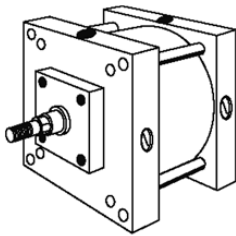

### ME4 CAP SQUARE FLANGE 8"-14"

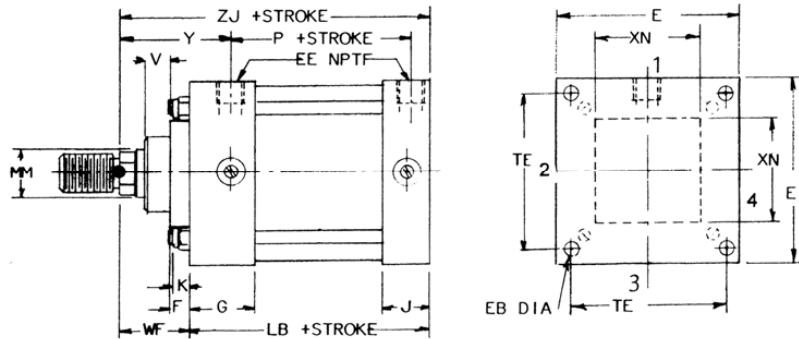
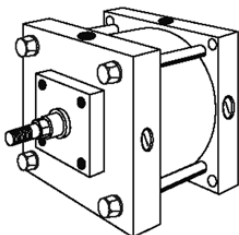

# Heavy Duty Pneumatic and Hydraulic NFPA Steel Cylinders

## POWERMASTER® PPT PNEUMATIC & PHT HYDRAULIC CYLINDERS

**TABLE 1** — Dimensions affected by rod diameter

BORE IN	MM ROD	V	W	WF	Y	XN	ZB	ZJ	ZL	ZM
1.500	0.625	0.25	0.63		1.94		4.85	4.63	5.73	6.13
	† 1.000	0.50	1.00		2.31		5.22	5.00	6.10	6.88
2.000	0.625	0.25	0.63		1.94		4.90	4.63	5.78	6.13
	1.000	0.50	1.00		2.31		5.27	5.00	6.15	6.88
	† 1.375	0.63	1.25		2.56		5.52	5.25	6.40	7.38
2.500	0.625	0.25	0.63		1.94		5.03	4.75	5.90	6.25
	1.000	0.50	1.00		2.31		5.40	5.13	6.27	7.00
	1.375	0.63	1.25		2.56		5.65	5.38	6.52	7.50
	† 1.750	0.75	1.50		2.81		5.90	5.63	6.77	8.00
3.250	1.000	0.25	0.75		2.44		5.97	5.63	7.09	7.50
	1.375	0.38	1.00		2.69		6.22	5.88	7.34	8.00
	1.750	0.50	1.25		2.94		6.47	6.13	7.59	8.50
	† 2.000	0.50	1.38		3.06		6.60	6.25	7.72	8.75
4.000	1.000	0.25	0.75		2.44		5.97	5.63	7.09	7.50
	1.375	0.38	1.00		2.69		6.22	5.88	7.34	8.00
	1.750	0.50	1.25		2.94		6.47	6.13	7.59	8.50
	2.000	0.50	1.38		3.06		6.60	6.25	7.72	8.75
5.000	2.500	0.63	1.63		3.31		6.85	6.50	7.97	9.25
	1.000	0.25	0.75		2.44		6.32	5.88	7.44	7.75
	1.375	0.38	1.00		2.69		6.57	6.13	7.69	8.25
	1.750	0.50	1.25		2.94		6.82	6.38	7.94	8.75
	2.000	0.50	1.38		3.06		6.95	6.50	8.07	9.00
	2.500	0.63	1.63		3.31		7.20	6.75	8.32	9.50
	3.000	0.63	1.63		3.31		7.20	6.75	8.32	9.50
	3.500	0.63	1.63		3.31		7.20	6.75	8.32	9.50
	1.375	0.25	0.88		2.81		7.07	6.63	8.32	8.75
	1.750	0.38	1.13		3.06		7.32	6.88	8.57	9.25
6.000	2.000	0.38	1.25		3.19		7.44	7.00	8.69	9.50
	2.500	0.50	1.50		3.44		7.69	7.25	8.94	10.00
	3.000	0.50	1.50		3.44		7.69	7.25	8.94	10.00
	3.500	0.50	1.50		3.44		7.69	7.25	8.94	10.00
	4.000	0.50	1.50		3.44		7.69	7.25	8.94	10.00
	1.375	0.25	1.50	1.63	2.81	4.00	7.32	6.75	7.82	8.88
8.000	1.750	0.38		1.88	3.06	4.00	7.57	7.00	8.07	9.38
	2.000	0.38		2.00	3.19	4.00	7.69	7.13	8.19	9.63
	2.500	0.50		2.25	3.44	4.00	7.94	7.38	8.44	10.13
	3.000	0.50		2.25	3.44	5.50	7.94	7.38	8.44	10.13
	3.500	0.50		2.25	3.44	5.50	7.94	7.38	8.44	10.13
	4.000	0.50		2.25	3.44	5.50	7.94	7.38	8.44	10.13
	4.500	0.50		2.25	3.44	6.50	7.94	7.38	8.44	10.13
	5.000	0.50		2.25	3.44	6.50	7.94	7.38	8.44	10.13
	5.500	0.50		2.25	3.44	7.25	7.94	7.38	8.44	10.13
	1.750	0.38		1.88	3.13	4.00	8.92	8.25	9.17	10.38
10.000	2.000	0.38		2.00	3.25	4.00	9.04	8.38	9.29	10.63
	2.500	0.50		2.25	3.50	4.00	9.29	8.63	9.54	11.13
	3.000	0.50		2.25	3.50	5.50	9.29	8.63	9.54	11.13
	3.500	0.50		2.25	3.50	5.50	9.29	8.63	9.54	11.13
	4.000	0.50		2.25	3.50	5.50	9.29	8.63	9.54	11.13
	4.500	0.50		2.25	3.50	6.50	9.29	8.63	9.54	11.13
	5.000	0.50		2.25	3.50	6.50	9.29	8.63	9.54	11.13
	5.500	0.50		2.25	3.50	7.25	9.29	8.63	9.54	11.13
	2.000	0.38		2.00	3.25	4.00	9.54	8.88	9.79	11.13
	12.000	2.500	0.50		2.25	3.50	4.00	9.79	9.13	10.04
3.000		0.50		2.25	3.50	5.50	9.79	9.13	10.04	11.63
3.500		0.50		2.25	3.50	5.50	9.79	9.13	10.04	11.63
4.000		0.50		2.25	3.50	5.50	9.79	9.13	10.04	11.63
4.500		0.50		2.25	3.50	6.50	9.79	9.13	10.04	11.63
5.000		0.50		2.25	3.50	6.50	9.79	9.13	10.04	11.63
14.000	5.500	0.50		2.25	3.50	7.25	9.79	9.13	10.04	11.63
	2.500	0.50		2.25	3.81	4.00	11.16	10.38	11.66	13.13
	3.000	0.50		2.25	3.81	5.50	11.16	10.38	11.66	13.13
	3.500	0.50		2.25	3.81	5.50	11.16	10.38	11.66	13.13
	4.000	0.50		2.25	3.81	5.50	11.16	10.38	11.66	13.13
	4.500	0.50		2.25	3.81	6.50	11.16	10.38	11.66	13.13
5.000	0.50		2.25	3.81	6.50	11.16	10.38	11.66	13.13	
5.500	0.50		2.25	3.81	7.25	11.16	10.38	11.66	13.13	

### DOUBLE ROD END CYLINDER HEAD SQUARE FLANGE MOUNT CAP SQUARE FLANGE MOUNT

Double rod end cylinders are available in every mounting style except clevis or pin type. For dimensions on specific mounting styles, consult the page showing the required mounting.

On cylinders where the rod ends are not the same, be sure to specify where each rod end is located in relation to the mounting requirement.

Note that bore sizes 1-1/2" — 6" have square retainers, and the same square size as the head on both ends. One of these retainers is held in place by the tie rod nuts and therefore cannot be removed without loosening the tie rods. 8" — 14" bore cylinders have retainers to the "XN" dimension.

Solid head and cap flanges mounts are some of the strongest, most rigid methods of mounting cylinders. The head flange type is best in a tension application. The cap flange type is best in a thrust application.

† Double rod end cylinders are available with fixed non-adjustable cushion on both ends. Head and cap flange cylinders are available with fixed non-adjustable cushion on the head end with Exact-a-just™ cushion on the cap or blind end.

**Double Rod End Pressure Rating—**  
See page 25

Rod end options are shown on page 72.

**TABLE 2**— Dimensions not affected by rod diameter

BORE IN	E	F	G	J	K	P	AA	DD THD	EB BOLT	EE NPTF	LB	LD	TE
1.500	2.00	0.38	1.50	1.00	0.22	2.25	2.02	0.25 –28		0.38		4.88	
2.000	2.50	0.38	1.50	1.00	0.27	2.25	2.60	0.31 –24		0.38		4.88	
2.500	3.00	0.38	1.50	1.00	0.27	2.38	3.10	0.31 –24		0.38		5.00	
3.250	3.75	0.63	1.75	1.25	0.34	2.63	3.90	0.38 –24		0.50		6.00	
4.000	4.50	0.63	1.75	1.25	0.34	2.63	4.70	0.38 –24		0.50		6.00	
5.000	5.50	0.63	1.75	1.25	0.44	2.88	5.80	0.50 –20		0.50		6.25	
6.000	6.50	0.75	2.00	1.50	0.44	3.13	6.90	0.50 –20		0.75		7.00	
8.000	8.50	0.75	2.00	1.50	0.56	3.25	9.10	0.63 –18	0.63	0.75	5.13	5.63	7.57
10.000	10.63	0.75	2.25	2.00	0.66	4.13	11.20	0.75 –16	0.75	1.00	6.38	6.63	9.40
12.000	12.75	0.75	2.25	2.00	0.66	4.63	13.30	0.75 –16	0.75	1.00	6.88	7.13	11.10
14.000	14.75	0.75	2.75	2.25	0.78	5.50	15.40	0.88 –14	0.88	1.25	8.13	8.63	12.87

# Heavy Duty Pneumatic and Hydraulic NFPA Steel Cylinders

## POWERMASTER® PPT PNEUMATIC & PHT HYDRAULIC CYLINDERS

### MF1 HEAD RECTANGULAR FLANGE 1-1/2" - 6"

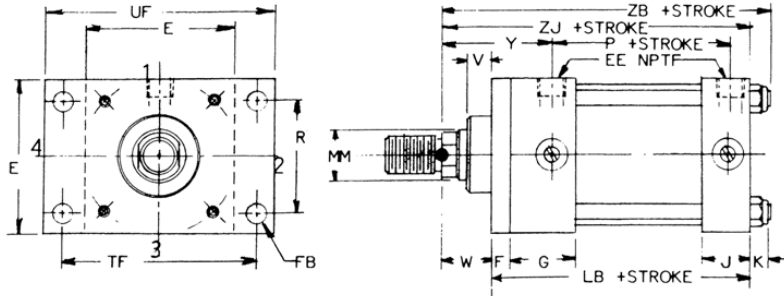
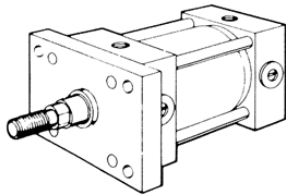

### MF2 CAP RECTANGULAR FLANGE 1-1/2" - 6"

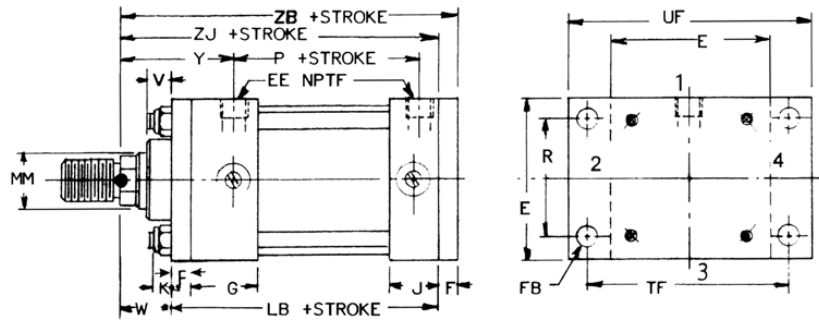
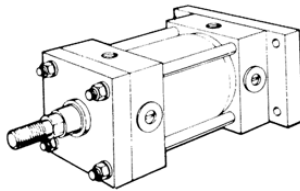

### MF5 HEAD SQUARE FLANGE 1-1/2" - 6"

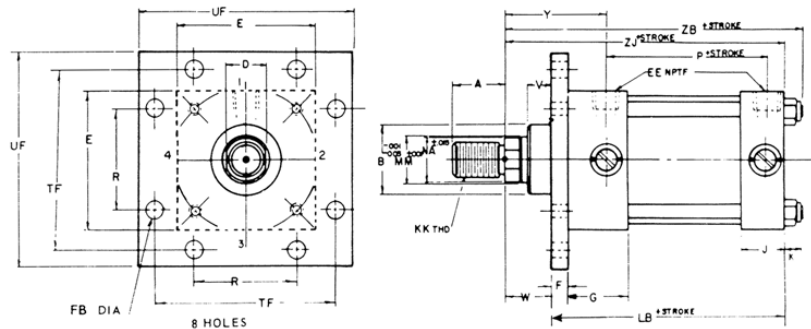
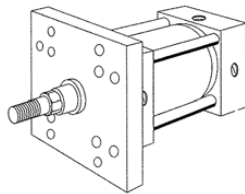

### MF6 CAP SQUARE FLANGE 1-1/2" - 6"

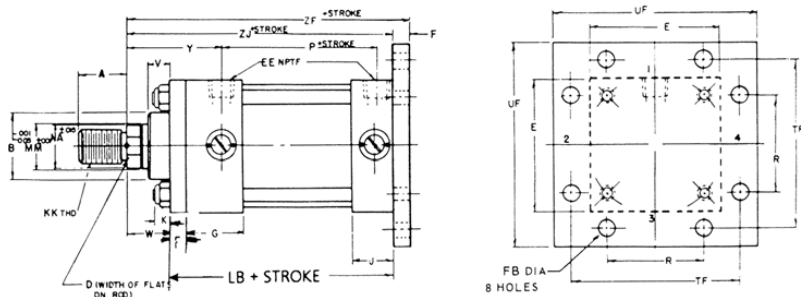
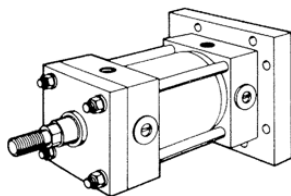



# Heavy Duty Pneumatic and Hydraulic NFPA Steel Cylinders

## POWERMASTER® PPT PNEUMATIC & PHT HYDRAULIC CYLINDERS

**TABLE 1** — Dimensions affected by rod diameter

BORE IN	MM ROD	V	W	Y	ZB	ZF	ZJ
1.500	0.625	0.25	0.63	1.94	4.85	5.00	4.63
	† 1.000	0.50	1.00	2.31	5.22	5.38	5.00
2.000	0.625	0.25	0.63	1.94	4.90	5.00	4.63
	1.000	0.50	1.00	2.31	5.27	5.38	5.00
	† 1.375	0.63	1.25	2.56	5.52	5.62	5.25
2.500	0.625	0.25	0.63	1.94	5.02	5.13	4.75
	1.000	0.50	1.00	2.31	5.40	5.50	5.13
	1.375	0.63	1.25	2.56	5.65	5.75	5.38
	† 1.750	0.75	1.50	2.81	5.90	6.00	5.63
3.250	1.000	0.25	0.75	2.44	5.98	6.25	5.63
	1.375	0.38	1.00	2.69	6.23	6.50	5.88
	1.750	0.50	1.25	2.94	6.48	6.75	6.13
	† 2.000	0.50	1.38	3.06	6.61	6.88	6.25
4.000	1.000	0.25	0.75	2.44	5.98	6.25	5.63
	1.375	0.38	1.00	2.69	6.23	6.50	5.88
	1.750	0.50	1.25	2.94	6.48	6.75	6.13
	2.000	0.50	1.38	3.06	6.61	6.88	6.25
	2.500	0.63	1.63	3.31	6.86	7.13	6.50
5.000	1.000	0.25	0.75	2.44	6.32	6.50	5.88
	1.375	0.38	1.00	2.69	6.57	6.75	6.13
	1.750	0.50	1.25	2.94	6.82	7.00	6.25
	2.000	0.50	1.38	3.06	6.94	7.13	6.50
	2.500	0.63	1.63	3.31	7.19	7.38	6.75
	3.000	0.63	1.63	3.31	7.19	7.38	6.75
	3.500	0.63	1.63	3.31	7.19	7.38	6.75
6.000	1.375	0.25	0.88	2.81	7.07	7.38	6.63
	1.750	0.38	1.13	3.06	7.32	7.63	6.88
	2.000	0.38	1.25	3.19	7.44	7.75	7.00
	2.500	0.50	1.50	3.44	7.69	8.00	7.25
	3.000	0.50	1.50	3.44	7.69	8.00	7.25
	3.500	0.50	1.50	3.44	7.69	8.00	7.25
	4.000	0.50	1.50	3.44	7.69	8.00	7.25

NOTE:

† Available with fixed cushioning on the rod end and Exact-a-just™ cushioning on the blind end.

Removable bearing retainer is not available in the 1-1/2" — 6" bore cylinders. The bearing retainer plate is the same as the "E" dimension for 1-1/2" — 6" bore sizes. Rod end options are shown on page 72.

**TABLE 2** — Dimensions not affected by rod diameter

BORE IN	E	F	G	J	K	P	R	EE NPTF	FB BOLT	LB	TF	UF
1.500	2.00	0.38	1.50	1.00	0.22	2.25	1.43	0.38	0.25	4.00	2.75	3.38
2.000	2.50	0.38	1.50	1.00	0.27	2.25	1.84	0.38	0.31	4.00	3.38	4.13
2.500	3.00	0.38	1.50	1.00	0.27	2.38	2.19	0.38	0.31	4.13	3.88	4.63
3.250	3.75	0.63	1.75	1.25	0.34	2.63	2.76	0.50	0.38	4.88	4.69	5.50
4.000	4.50	0.63	1.75	1.25	0.34	2.63	3.32	0.50	0.38	4.88	5.44	6.25
5.000	5.50	0.63	1.75	1.25	0.44	2.88	4.10	0.50	0.50	5.13	6.63	7.63
6.000	6.50	0.75	2.00	1.50	0.44	3.13	4.88	0.75	0.50	5.75	7.63	8.63

### FLANGE MOUNTS

Flange mounts are one of the strongest, most rigid methods of mounting. With this type of mount, there is little allowance for misalignment, so when long strokes are required, the free end opposite the mounting should be supported to prevent sagging and possible binding of the cylinder. Blind or cap end mounts are best for thrust load applications, and rod or head end mounts are best in tension applications. If an application exceeds the rectangular flange rating, a solid head or cap flange mount (ME3) or (ME4) is available. (Refer to page 11).

When a less rigid mount can be used and the cylinder can be attached to a panel or bulkhead, an extended tie rod mount could be considered.

Note: The maximum hydraulic pressure rating for MF1 and MF2 mounts in 1000 psi.

# Heavy Duty Pneumatic and Hydraulic NFPA Steel Cylinders

POWERMASTER® PPT PNEUMATIC & PHT HYDRAULIC CYLINDERS

## FIXED & DETACHABLE CLEVIS MOUNTS AND UNIVERSAL CLEVIS MOUNT

**MP1 CAP FIXED CLEVIS**  
1-1/2" — 14"

**MP3 CAP FIXED EYE**  
1-1/2" — 8"

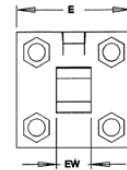
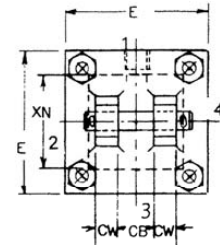
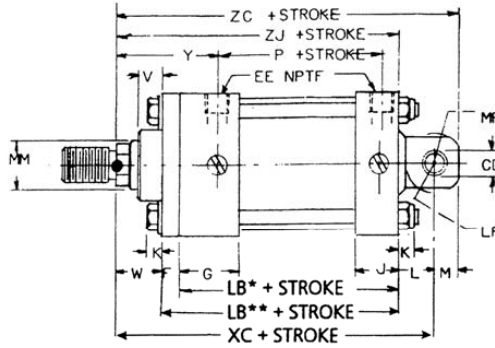
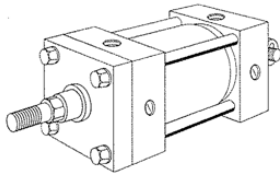

MP3, MP4 Cap

\*8" - 14" Bores only  
\*\*1-1/2" - 6" Bores only

**MP2 CAP DETACHABLE CLEVIS**  
1-1/2" — 8"

**MP4 CAP DETACHABLE EYE**  
1-1/2" — 8"

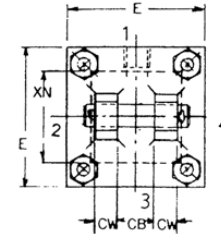
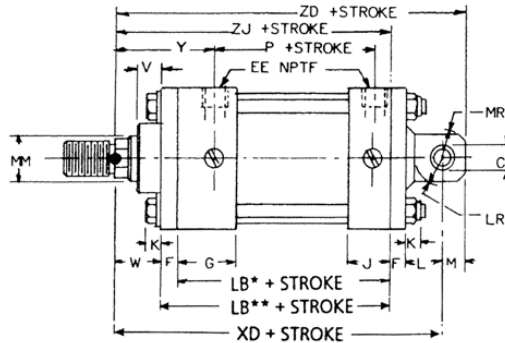
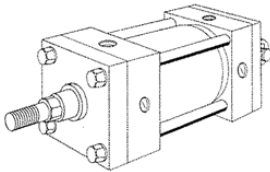

\*8" Bore only  
\*\*1-1/2" - 6" Bores only

**MU3 UNIVERSAL CLEVIS**  
1-1/2" — 6"

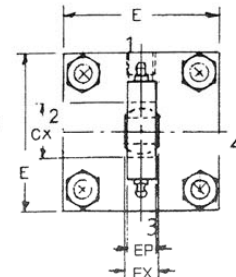
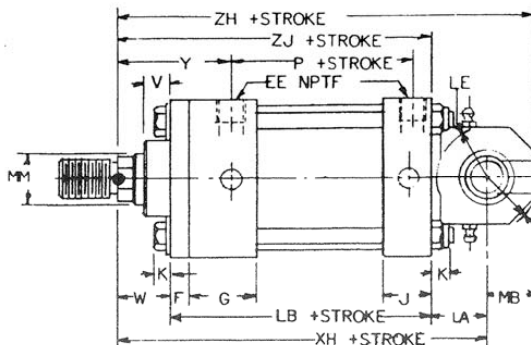
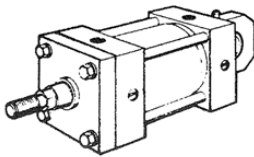

# Heavy Duty Pneumatic and Hydraulic NFPA Steel Cylinders

## POWERMASTER® PPT PNEUMATIC & PHT HYDRAULIC CYLINDERS

TABLE 1— Dimensions affected by rod diameter

BORE IN	MM ROD	V	W	WF	Y	XC	XD	XH	XN	ZC	ZD	ZH	ZJ
1.500	0.625	0.25	0.63		1.94	5.38	5.75	5.50		5.88	6.25	6.25	4.63
	1.000	0.50	1.00		2.31	5.75	6.13	5.88		6.25	6.63	6.63	5.00
2.000	0.625	0.25	0.63		1.94	5.38	5.75	5.50		5.88	6.25	6.25	4.63
	1.000	0.50	1.00		2.31	5.75	6.13	5.88		6.25	6.63	6.63	5.00
2.500	1.375	0.63	1.25		2.56	6.00	6.38	6.13		6.50	6.88	6.88	5.25
	0.625	0.25	0.63		1.94	5.50	5.88	5.63		6.00	6.38	6.38	4.75
	1.000	0.50	1.00		2.31	5.88	6.25	6.00		6.38	6.75	6.75	5.13
	1.375	0.63	1.25		2.56	6.13	6.50	6.25		6.63	7.00	7.00	5.38
3.250	1.750	0.75	1.50		2.81	6.38	6.75	6.50		6.88	7.25	7.25	5.63
	1.000	0.25	0.75		2.44	6.88	7.50	6.88		7.63	8.25	8.13	5.63
	1.375	0.38	1.00		2.69	7.13	7.75	7.13		7.88	8.50	8.38	5.88
	1.750	0.50	1.25		2.94	7.38	8.00	7.38		8.13	8.75	8.63	6.13
4.000	2.000	0.50	1.38		3.06	7.50	8.13	7.50		8.25	8.88	8.75	6.25
	1.000	0.25	0.75		2.44	6.88	7.50	6.88		7.63	8.25	8.13	5.63
	1.375	0.38	1.00		2.69	7.13	7.75	7.13		7.88	8.50	8.38	5.88
	1.750	0.50	1.25		2.94	7.38	8.00	7.38		8.13	8.75	8.63	6.13
5.000	2.500	0.63	1.63		3.31	7.75	8.38	7.75		8.50	9.13	9.00	6.50
	1.000	0.25	0.75		2.44	7.13	7.75	7.13		7.88	8.50	8.38	5.88
	1.375	0.38	1.00		2.69	7.38	8.00	7.38		8.13	8.75	8.63	6.13
	1.750	0.50	1.25		2.94	7.63	8.25	7.63		8.38	9.00	8.88	6.83
6.000	2.000	0.50	1.38		3.06	7.75	8.38	7.75		8.50	9.13	9.00	6.50
	2.500	0.63	1.63		3.31	8.00	8.63	8.00		8.75	9.38	9.25	6.75
	3.000	0.63	1.63		3.31	8.00	8.63	8.00		8.75	9.38	9.25	6.75
	3.500	0.63	1.63		3.31	8.00	8.63	8.00		8.75	9.38	9.25	6.75
8.000	1.375	0.25	0.88		2.81	8.13	8.88	8.25		9.13	9.88	9.75	6.63
	1.750	0.38	1.13		3.06	8.38	9.13	8.50		9.38	10.13	10.00	6.88
	2.000	0.38	1.25		3.19	8.50	9.25	8.63		9.50	10.25	10.13	7.00
	2.500	0.50	1.50		3.44	8.75	9.50	8.88		9.75	10.50	10.38	7.25
10.000	3.000	0.50	1.50		3.44	8.75	9.50	8.88		9.75	10.50	10.38	7.25
	3.500	0.50	1.50		3.44	8.75	9.50	8.88		9.75	10.50	10.38	7.25
	4.000	0.50	1.50		3.44	8.75	9.50	8.88		9.75	10.50	10.38	7.25
	4.500	0.50	1.50		3.44	8.75	9.50	8.88		9.75	10.50	10.38	7.25
12.000	5.000	0.50	1.50		3.44	8.75	9.50	8.88		9.75	10.50	10.38	7.25
	5.500	0.50	1.50		3.44	8.75	9.50	8.88		9.75	10.50	10.38	7.25
	1.375	0.25	0.88	1.63	2.81	8.25	9.25		4.00	9.25	10.25		6.75
	1.750	0.38	1.13	1.88	3.06	8.50	9.50		4.00	9.50	10.50		7.00
14.000	2.000	0.38	1.25	2.00	3.19	8.63	9.63		4.00	9.63	10.63		7.13
	2.500	0.50	1.50	2.25	3.44	8.88	9.88		4.00	9.88	10.88		7.38
	3.000	0.50	1.50	2.25	3.44	8.88	9.88		5.50	9.88	10.88		7.38
	3.500	0.50	1.50	2.25	3.44	8.88	9.88		5.50	9.88	10.88		7.38
16.000	4.000	0.50	1.50	2.25	3.44	8.88	9.88		5.50	9.88	10.88		7.38
	4.500	0.50	1.50	2.25	3.44	8.88	9.88		6.50	9.88	10.88		7.38
	5.000	0.50	1.50	2.25	3.44	8.88	9.88		6.50	9.88	10.88		7.38
	5.500	0.50	1.50	2.25	3.44	8.88	9.88		7.25	9.88	10.88		7.38
18.000	1.750	0.38	1.13	1.88	3.13	10.38			4.00	11.75			8.25
	2.000	0.38	1.25	2.00	3.25	10.50			4.00	11.88			8.38
	2.500	0.50	1.50	2.25	3.50	10.75			4.00	12.13			8.63
	3.000	0.50	1.50	2.25	3.50	10.75			5.50	12.13			8.63
20.000	3.500	0.50	1.50	2.25	3.50	10.75			5.50	12.13			8.63
	4.000	0.50	1.50	2.25	3.50	10.75			5.50	12.13			8.63
	4.500	0.50	1.50	2.25	3.50	10.75			6.50	12.13			8.63
	5.000	0.50	1.50	2.25	3.50	10.75			6.50	12.13			8.63
22.000	5.500	0.50	1.50	2.25	3.50	10.75			7.25	12.13			8.63
	2.000	0.38	1.13	2.00	3.25	11.13			4.00	12.88			8.88
	2.500	0.50	1.38	2.25	3.50	11.38			4.00	13.13			9.13
	3.000	0.50	1.38	2.25	3.50	11.38			5.50	13.13			9.13
24.000	3.500	0.50	1.38	2.25	3.50	11.38			5.50	13.13			9.13
	4.000	0.50	1.38	2.25	3.50	11.38			5.50	13.13			9.13
	4.500	0.50	1.38	2.25	3.50	11.38			6.50	13.13			9.13
	5.000	0.50	1.38	2.25	3.50	11.38			6.50	13.13			9.13
26.000	5.500	0.50	1.38	2.25	3.50	11.38			7.25	13.13			9.13
	2.500	0.50	1.38	2.25	3.81	12.88			4.00	14.88			10.38
	3.000	0.50	1.38	2.25	3.81	12.88			5.50	14.88			10.38
	3.500	0.50	1.38	2.25	3.81	12.88			5.50	14.88			10.38
28.000	4.000	0.50	1.38	2.25	3.81	12.88			5.50	14.88			10.38
	4.500	0.50	1.38	2.25	3.81	12.88			6.50	14.88			10.38
	5.000	0.50	1.38	2.25	3.81	12.88			6.50	14.88			10.38
	5.500	0.50	1.38	2.25	3.81	12.88			7.25	14.88			10.38

### FIXED & DETACHABLE CLEVIS MOUNT & UNIVERSAL CLEVIS MOUNT

The Clevis or Pin mounted cylinder is probably the most widely used of all mounts. For short strokes, medium or small cylinder applications, the clevis mounts are recommended. If this mount is applied where stroke requirements cause the overall length to be excessive, the Cap Trunnion mount can be used. Pivot mounts must always be used with a pivot type rod end attachment.

#### NOTES:

† Available with fixed, non-adjustable cushion on the rod end and Exact-a-just™ cushioning on the blind or cap end only

The bearing retainer plate is the same as the "E" dimension for 1-1/2" — 6" bore sizes and the "XN" dimension for the 8" — 14" bore sizes.

† Rod end options are shown on page 72.

MP1 and MP2 mounts include pivot pin. MU3 does not include pivot pin.

TABLE 2— Dimensions not affected by rod diameter

BORE IN	E	F	G	J	K	L	M	P	EW/CB	CD	CW	CX	EE NPT	EX	EP	LA	LB	LE	LR	MA	MB	MR
1.500	2.00	0.38	1.50	1.00	0.22	0.75	0.50	2.25	0.75	0.500	0.50	0.87	0.38	0.437	0.38	0.88	4.00	0.63	0.59	0.88	0.75	0.69
2.000	2.50	0.38	1.50	1.00	0.27	0.75	0.50	2.25	0.75	0.500	0.50	0.87	0.38	0.437	0.38	0.88	4.00	0.63	0.59	0.88	0.75	0.69
2.500	3.00	0.38	1.50	1.00	0.27	0.75	0.50	2.38	0.75	0.500	0.50	0.87	0.38	0.437	0.38	0.88	4.13	0.63	0.59	0.88	0.75	0.69
3.250	3.75	0.63	1.75	1.25	0.34	1.25	0.75	2.63	1.25	0.750	0.63	1.25	0.50	0.656	0.56	1.25	4.88	0.94	0.88	1.38	1.25	1.00
4.000	4.50	0.63	1.75	1.25	0.34	1.25	0.75	2.63	1.25	0.750	0.63	1.25	0.50	0.656	0.56	1.25	4.88	0.94	0.88	1.38	1.25	1.00
5.000	5.50	0.63	1.75	1.25	0.44	1.25	0.75	2.88	1.25	0.750	0.63	1.25	0.50	0.656	0.56	1.25	5.13	0.94	0.88	1.38	1.25	1.00
6.000	6.50	0.75	2.00	1.50	0.44	1.50	1.00	3.13	1.50	1.000	0.75	1.63	0.75	0.875	0.75	1.63	5.75	1.13	1.19	1.63	1.50	1.38
8.000	8.50	0.75	2.00	1.50	0.56	1.50	1.00	3.25	1.50	1.000	0.75		0.75				5.13		1.19			1.38
10.000	10.63	0.75	2.25	2.00	0.66	2.13	1.38	4.13	2.00	1.375	1.00		1.00				6.38		1.63			2.00
12.000	12.75	0.75	2.25	2.00	0.66	2.25	1.75	4.63	2.50	1.750	1.25		1.00				6.88		2.06			2.25
14.000	14.75	0.75	2.75	2.75	0.78	2.50	2.00	5.50	2.50	2.000	1.25		1.25				8.13		2.38			2.50

# Heavy Duty Pneumatic and Hydraulic NFPA Steel Cylinders

POWERMASTER® PPT PNEUMATIC & PHT HYDRAULIC CYLINDERS

## SIDE END LUG & SIDE END ANGLE MOUNT

### MS1 SIDE END 1-1/2"–14"

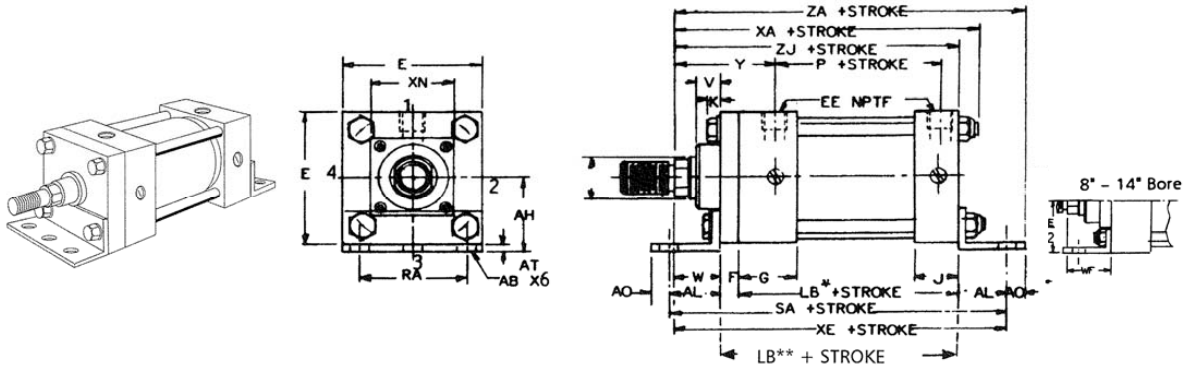

\*8" - 14" Bores only  
\*\*1-1/2" - 6" Bores only

### MS7 SIDE END LUGS 1-1/2"–14"

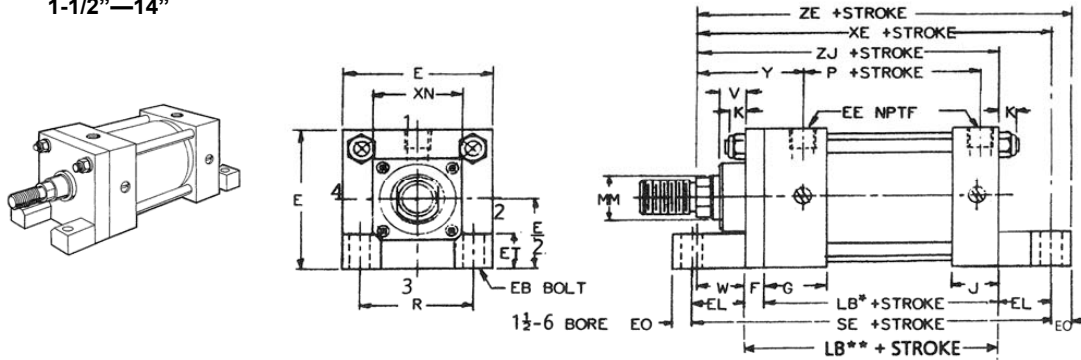

\*8" - 14" Bores only  
\*\*1-1/2" - 6" Bores only

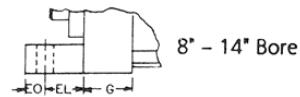

# Heavy Duty Pneumatic and Hydraulic NFPA Steel Cylinders

## POWERMASTER® PPT PNEUMATIC & PHT HYDRAULIC CYLINDERS

**TABLE 1—** Dimensions affected by rod diameter

BORE IN	MM ROD	V	W	WF	Y	XA	XE	XN	ZA	ZB	ZE	ZJ
1.5000	0.625	0.25	0.63		1.94	5.63	5.38		6.00	4.85	5.63	4.63
	1.000	0.50	1.00		2.31	6.00	5.75		6.38	5.22	6.00	5.00
	0.625	0.25	0.63		1.94	5.63	5.56		6.00	4.90	5.88	4.63
2.000	1.000	0.50	1.00		2.31	6.00	5.94		6.38	5.27	6.25	5.00
	1.375	0.63	1.25		2.56	6.25	6.19		6.63	5.52	6.50	5.25
	0.625	0.25	0.63		1.94	5.75	5.81		6.13	5.02	6.13	4.75
2.500	1.000	0.50	1.00		2.31	6.13	6.19		6.50	5.40	6.50	5.13
	1.375	0.63	1.25		2.56	6.38	6.44		6.75	5.65	6.75	5.38
	1.750	0.75	1.50		2.81	6.63	6.69		7.00	5.90	7.00	5.63
3.250	1.000	0.25	0.75		2.44	6.88	6.50		7.38	5.98	6.88	5.63
	1.375	0.38	1.00		2.69	7.13	6.75		7.63	6.23	7.13	5.88
	1.750	0.50	1.25		2.94	7.38	7.00		7.88	6.48	7.38	6.13
4.000	2.000	0.50	1.38		3.06	7.50	7.13		8.00	6.61	7.50	6.25
	1.000	0.25	0.75		2.44	6.88	6.63		7.38	5.98	7.00	5.63
	1.375	0.38	1.00		2.69	7.13	6.88		7.63	6.23	7.25	5.88
5.000	1.750	0.50	1.25		2.94	7.38	7.13		7.88	6.48	7.50	6.13
	2.000	0.50	1.38		3.06	7.50	7.25		8.00	6.61	7.63	6.25
	2.500	0.63	1.63		3.31	7.75	7.50		8.25	6.86	7.88	6.50
6.000	1.000	0.25	0.75		2.44	7.25	6.94		7.88	6.32	7.44	5.88
	1.375	0.38	1.00		2.69	7.50	7.19		8.13	6.57	7.69	6.13
	1.750	0.50	1.25		2.94	7.75	7.44		8.38	6.82	7.94	6.38
8.000	2.000	0.50	1.38		3.06	7.88	7.56		8.50	6.94	8.06	6.50
	2.500	0.63	1.63		3.31	8.13	7.81		8.75	7.19	8.31	6.75
	3.000	0.63	1.63		3.31	8.13	7.81		8.75	7.19	8.31	6.75
10.000	3.500	0.63	1.63		3.31	8.13	7.81		8.75	7.19	8.31	6.75
	1.375	0.25	0.88		2.81	8.00	7.63		8.63	7.07	8.13	6.63
	1.750	0.38	1.13		3.06	8.25	7.88		8.88	7.32	8.38	6.88
12.000	2.000	0.38	1.25		3.19	8.38	8.00		9.00	7.44	8.50	7.00
	2.500	0.50	1.50		3.44	8.63	8.25		9.25	7.69	8.75	7.25
	3.000	0.50	1.50		3.44	8.63	8.25		9.25	7.69	8.75	7.25
14.000	3.500	0.50	1.50		3.44	8.63	8.25		9.25	7.69	8.75	7.25
	4.000	0.50	1.50		3.44	8.63	8.25		9.25	7.69	8.75	7.25
	1.375	0.25		1.63	2.81	8.56	7.88	4.00	9.25	7.31	8.50	6.75
16.000	1.750	0.38		1.88	3.06	8.81	8.13	4.00	9.50	7.56	8.75	7.00
	2.000	0.38		2.00	3.19	8.94	8.25	4.00	9.63	7.69	8.88	7.13
	2.500	0.50		2.25	3.44	9.19	9.25	4.00	9.88	7.94	9.88	7.38
18.000	3.000	0.50		2.25	3.44	9.19	9.25	5.50	9.88	7.94	9.88	7.38
	3.500	0.50		2.25	3.44	9.19	9.25	5.50	9.88	7.94	9.88	7.38
	4.000	0.50		2.25	3.44	9.19	9.25	5.50	9.88	7.94	9.88	7.38
20.000	4.500	0.50		2.25	3.44	9.19	9.25	6.50	9.88	7.94	9.88	7.38
	5.000	0.50		2.25	3.44	9.19	9.25	6.50	9.88	7.94	9.88	7.38
	5.500	0.50		2.25	3.44	9.19	9.25	7.25	9.88	7.94	9.88	7.38
22.000	1.750	0.38		1.88	3.13	10.38	9.56	4.00	11.25	8.91	10.19	8.25
	2.000	0.38		2.00	3.25	10.50	9.69	4.00	11.38	9.03	10.31	8.38
	2.500	0.50		2.25	3.50	10.75	9.94	4.00	11.63	9.28	10.56	8.63
24.000	3.000	0.50		2.25	3.50	10.75	9.94	5.50	11.63	9.28	10.56	8.63
	3.500	0.50		2.25	3.50	10.75	9.94	5.50	11.63	9.28	10.56	8.63
	4.000	0.50		2.25	3.50	10.75	9.94	5.50	11.63	9.28	10.56	8.63
26.000	4.500	0.50		2.25	3.50	10.75	9.94	6.50	11.63	9.28	10.56	8.63
	5.000	0.50		2.25	3.50	10.75	9.94	6.50	11.63	9.28	10.56	8.63
	5.500	0.50		2.25	3.50	10.75	9.94	7.25	11.63	9.28	10.56	8.63
28.000	2.000	0.38		2.00	3.25	11.00	10.19	4.00	11.88	9.53	10.81	8.88
	2.500	0.50		2.25	3.50	11.25	10.44	4.00	12.13	9.78	11.06	9.13
	3.000	0.50		2.25	3.50	11.25	10.44	5.50	12.13	9.78	11.06	9.13
30.000	3.500	0.50		2.25	3.50	11.25	10.44	5.50	12.13	9.78	11.06	9.13
	4.000	0.50		2.25	3.50	11.25	10.44	5.50	12.13	9.78	11.06	9.13
	4.500	0.50		2.25	3.50	11.25	10.44	6.50	12.13	9.78	11.06	9.13
32.000	5.000	0.50		2.25	3.50	11.25	10.44	6.50	12.13	9.78	11.06	9.13
	5.500	0.50		2.25	3.50	11.25	10.44	7.25	12.13	9.78	11.06	9.13
	2.500	0.50		2.25	3.81	12.81	11.88	4.00	13.88	11.16	12.63	10.38
34.000	3.000	0.50		2.25	3.81	12.81	11.88	5.00	13.88	11.16	12.63	10.38
	3.500	0.50		2.25	3.81	12.81	11.88	5.50	13.88	11.16	12.63	10.38
	4.000	0.50		2.25	3.81	12.81	11.88	5.50	13.88	11.16	12.63	10.38
36.000	4.500	0.50		2.25	3.81	12.81	11.88	6.50	13.88	11.16	12.63	10.38
	5.000	0.50		2.25	3.81	12.81	11.88	6.50	13.88	11.16	12.63	10.38
	5.500	0.50		2.25	3.81	12.81	11.88	7.25	13.88	11.16	12.63	10.38

### SIDE END LUG AND ANGLE MOUNTS

The side end mounts lend themselves to easy mounting and replacement. They also permit side by side mounting in confined areas. As with the side lug mounts, proper use will place the bolts in simple shear or tension without any compound stresses. The alignment is critical to maximum service life.

When specifying these mounts, carefully check the distance between the rod and lug or angle to determine if there is sufficient clearance for the rod end attachment. It may be necessary to add a plain rod extension to move the threaded rod end out beyond the lug.

These mounts require the loosening of the tie rods to remove the rod gland for bore sizes 1-1/2"–6".

**NOTE:**

- † Available with fixed non-adjustable cushion on the rod end and standard Exact-a-just™ cushion on the cap end only.

The bearing retainer plate is the same as the "E" dimension for the 1-1/2"–6" bore sizes and the "XN" dimension for the 8"–14" bore sizes.

Rode end options are shown on page 72.

- For double rod cylinders 1-1/2" thru 8" bore, add 1/2", for 10 & 12" bore, add 1/4", for 14" bore add 1/2".

**TABLE 2—** Dimensions not affected by rod diameter

BORE IN	E	F	G	J	K	P	R	AA	AB BOLT	AH	AL	AO	AT	EB BOLT	EE NPTF	EL	EO	ET	LB	RA	SA	SE
1.500	2.00	0.38	1.50	1.00	0.22	2.25	1.43	2.02	0.38	1.19	1.00	0.38	0.13	0.25	0.38	0.75	0.25	0.56	4.00	1.25	6.00	5.50
2.000	2.50	0.38	1.50	1.00	0.27	2.25	1.84	2.60	0.38	1.44	1.00	0.38	0.13	0.31	0.38	0.94	0.31	0.69	4.00	1.75	6.00	5.88
2.500	3.00	0.38	1.50	1.00	0.27	2.38	2.19	3.10	0.38	1.63	1.00	0.38	0.13	0.31	0.38	1.06	0.31	0.81	4.13	2.25	6.13	6.25
3.250	3.75	0.63	1.75	1.25	0.34	2.63	2.76	3.90	0.50	1.94	1.25	0.50	0.13	0.38	0.50	0.88	0.38	1.00	4.88	2.75	7.38	6.63
4.000	4.50	0.63	1.75	1.25	0.34	2.63	3.32	4.70	0.50	2.25	1.25	0.50	0.13	0.38	0.50	1.00	0.38	1.19	4.88	3.50	7.38	6.88
5.000	5.50	0.63	1.75	1.25	0.44	2.88	4.10	5.80	0.63	2.75	1.38	0.63	0.19	0.50	0.50	1.06	0.50	1.38	5.13	4.25	7.88	7.25
6.000	6.50	0.75	2.00	1.50	0.44	3.13	4.88	6.90	0.75	3.25	1.38	0.63	0.19	0.50	0.75	1.00	0.50	1.63	5.75	5.25	8.50	7.75
8.000	8.50	0.75	2.00	1.50	0.56	3.25	6.44	9.10	0.75	4.25	1.81	0.69	0.25	0.63	0.75	1.13	0.63	2.06	5.13	7.13	8.75	7.38
10.000	10.63	0.75	2.25	2.00	0.66	4.13	7.92	11.20	1.00	5.31	2.13	0.88	0.25	0.75	1.00	1.31	0.63	2.69	6.38	8.88	10.63	9.00
12.000	12.75	0.75	2.25	2.00	0.66	4.63	9.40	13.30	1.00	6.38	2.13	0.88	0.38	0.75	1.00	1.31	0.63	3.31	6.88	11.00	11.13	9.50
14.000	14.75	0.75	2.75	2.25	0.78	5.50	10.90	15.40	1.25	7.38	2.44	1.06	0.38	0.88	1.25	1.50	0.75	3.81	8.13	12.63	13.00	11.13



# Heavy Duty Pneumatic and Hydraulic NFPA Steel Cylinders

POWERMASTER® PPT PNEUMATIC & PHT HYDRAULIC CYLINDERS

## SIDE & CENTERLINE LUG MOUNTS AND SIDE MOUNTS

### MS2 SIDE LUGS 1-1/2"–14"

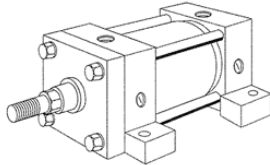

\*8" - 14" Bores only  
\*\*1-1/2" - 6" Bores only

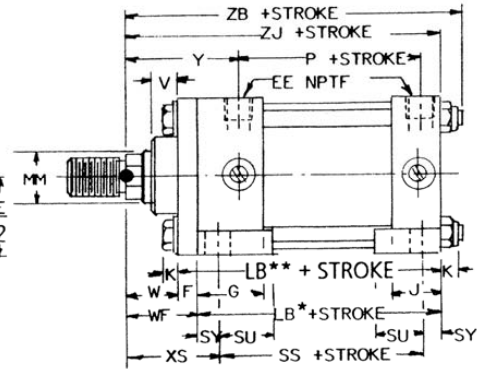
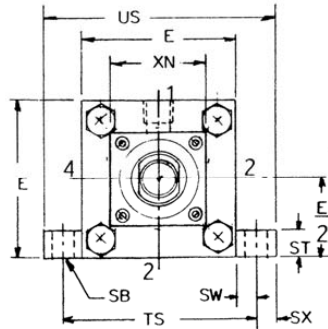

### MS3 CENTERLINE LUGS 1-1/2"–14"

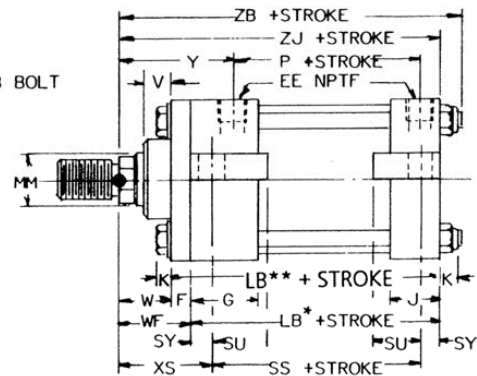
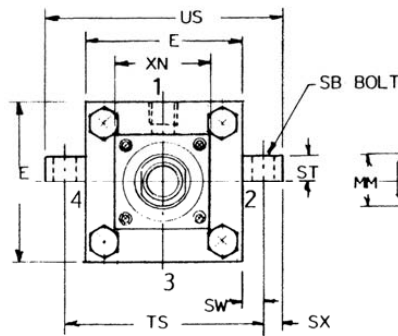
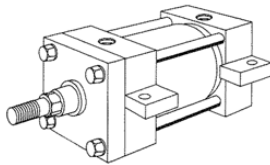

### MS4 SIDE TAPPED 1-1/2"–14"

### MX0 NO MOUNTINGS§ 1-1/2"–14"

§ Same as MS4 less mounting holes

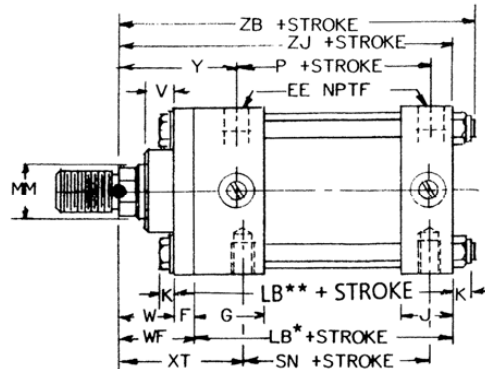
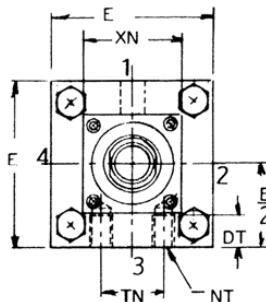
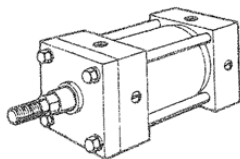

# Heavy Duty Pneumatic and Hydraulic NFPA Steel Cylinders

## POWERMASTER® PPT PNEUMATIC & PHT HYDRAULIC CYLINDERS

TABLE 1— Dimensions affected by rod diameter

BORE IN	MM ROD	V	W	WF	Y	XN	XS	XT	ZB	ZJ
1.500	0.625	0.25	0.63		1.94		1.38	1.94	4.85	4.63
	† 1.000	0.50	1.00		2.31		1.75	2.31	5.22	5.00
2.000	0.625	0.25	0.63		1.94		1.38	1.94	4.90	4.63
	1.000	0.50	1.00		2.31		1.75	2.31	5.27	5.00
	† 1.375	0.63	1.25		2.56		2.00	2.56	5.52	5.25
2.500	0.625	0.25	0.63		1.94		1.38	1.94	5.02	4.75
	1.000	0.50	1.00		2.31		1.75	2.31	5.40	5.13
	1.375	0.63	1.25		2.56		2.00	2.56	5.65	5.38
	† 1.750	0.75	1.50		2.81		2.25	2.81	5.90	5.63
3.250	1.000	0.25	0.75		2.44		1.88	2.44	5.98	5.63
	1.375	0.38	1.00		2.69		2.13	2.69	6.23	5.88
	1.750	0.50	1.25		2.94		2.38	2.94	6.48	6.13
	† 2.000	0.50	1.38		3.06		2.50	3.06	6.61	6.25
4.000	1.000	0.25	0.75		2.44		1.88	2.44	5.98	5.63
	1.375	0.38	1.00		2.69		2.13	2.69	6.23	5.88
	1.750	0.50	1.25		2.94		2.38	2.94	6.48	6.13
	2.000	0.50	1.38		3.06		2.50	3.06	6.61	6.25
5.000	1.000	0.25	0.75		2.44		2.06	2.44	6.32	5.88
	1.375	0.38	1.00		2.69		2.31	2.69	6.57	6.13
	1.750	0.50	1.25		2.94		2.56	2.94	6.82	6.38
	2.000	0.50	1.38		3.06		2.69	3.06	6.94	6.50
6.000	2.500	0.63	1.63		3.31		2.94	3.31	7.19	6.75
	3.000	0.63	1.63		3.31		2.94	3.31	7.19	6.75
	3.500	0.63	1.63		3.31		2.94	3.31	7.19	6.75
	1.375	0.25	0.88		2.81		2.31	2.81	7.07	6.63
8.000	1.750	0.38	1.13		3.06		2.56	3.06	7.32	6.88
	2.000	0.38	1.25		3.19		2.69	3.19	7.44	7.00
	2.500	0.50	1.50		3.44		2.94	3.44	7.69	7.25
	3.000	0.50	1.50		3.44		2.94	3.44	7.69	7.25
10.000	3.500	0.50	1.50		3.44		2.94	3.44	7.69	7.25
	4.000	0.50	1.50		3.44		2.94	3.44	7.69	7.25
	4.500	0.50	1.50		3.44		2.94	3.44	7.69	7.25
	5.000	0.50	1.50		3.44		2.94	3.44	7.69	7.25
12.000	5.500	0.50	1.50		3.44		2.94	3.44	7.69	7.25
	1.375	0.25		1.63	2.81	4.00	2.31	2.81	7.31	6.75
	1.750	0.38		1.88	3.06	4.00	2.56	3.06	7.56	7.00
	2.000	0.38		2.00	3.19	4.00	2.69	3.19	7.69	7.13
14.000	2.500	0.50		2.25	3.44	4.00	2.94	3.44	7.94	7.38
	3.000	0.50		2.25	3.44	5.50	2.94	3.44	7.94	7.38
	3.500	0.50		2.25	3.44	5.50	2.94	3.44	7.94	7.38
	4.000	0.50		2.25	3.44	5.50	2.94	3.44	7.94	7.38
16.000	4.500	0.50		2.25	3.44	6.50	2.94	3.44	7.94	7.38
	5.000	0.50		2.25	3.44	6.50	2.94	3.44	7.94	7.38
	5.500	0.50		2.25	3.44	7.25	2.94	3.44	7.94	7.38
	6.000	0.50		2.25	3.44	7.25	2.94	3.44	7.94	7.38
18.000	1.750	0.38		1.88	3.13	4.00	2.75	3.13	8.91	8.25
	2.000	0.38		2.00	3.25	4.00	2.88	3.25	9.03	8.38
	2.500	0.50		2.25	3.50	4.00	3.13	3.50	9.28	8.63
	3.000	0.50		2.25	3.50	5.50	3.13	3.50	9.28	8.63
20.000	3.500	0.50		2.25	3.50	5.50	3.13	3.50	9.28	8.63
	4.000	0.50		2.25	3.50	5.50	3.13	3.50	9.28	8.63
	4.500	0.50		2.25	3.50	6.50	3.13	3.50	9.28	8.63
	5.000	0.50		2.25	3.50	6.50	3.13	3.50	9.28	8.63
22.000	5.500	0.50		2.25	3.50	7.25	3.13	3.50	9.28	8.63
	2.000	0.38		2.00	3.25	4.00	2.88	3.25	9.53	8.88
	2.500	0.50		2.25	3.50	4.00	3.13	3.50	9.78	9.13
	3.000	0.50		2.25	3.50	5.50	3.13	3.50	9.78	9.13
24.000	3.500	0.50		2.25	3.50	5.50	3.13	3.50	9.78	9.13
	4.000	0.50		2.25	3.50	5.50	3.13	3.50	9.78	9.13
	4.500	0.50		2.25	3.50	6.50	3.13	3.50	9.78	9.13
	5.000	0.50		2.25	3.50	6.50	3.13	3.50	9.78	9.13
26.000	5.500	0.50		2.25	3.50	7.25	3.13	3.50	9.78	9.13
	2.500	0.50		2.25	3.81	4.00	3.38	3.81	11.16	10.38
	3.000	0.50		2.25	3.81	5.50	3.38	3.81	11.16	10.38
	3.500	0.50		2.25	3.81	5.50	3.38	3.81	11.16	10.38
28.000	4.000	0.50		2.25	3.81	5.50	3.38	3.81	11.16	10.38
	4.500	0.50		2.25	3.81	6.50	3.38	3.81	11.16	10.38
	5.000	0.50		2.25	3.81	6.50	3.38	3.81	11.16	10.38
	5.500	0.50		2.25	3.81	7.25	3.38	3.81	11.16	10.38

### SIDE AND CENTERLINE LUG MOUNTS

The side or lug mounted cylinder provides a fairly rigid mount. These type mounts can tolerate a slight amount of misalignment when the cylinder is at full stroke, but as the piston moves toward the blind end, the tolerance for misalignment decreases. It is important to note that if the cylinder is used properly the mounting bolts are either in simple shear or tension without any compound stresses.

#### NOTES:

When specifying an MS2 mount with ports in the 2 or 4 quadrant, be sure there is sufficient clearance between the port fitting and the lug to insert a bolt or cap screw into the lug.

† Available with fixed non-adjustable cushioning on the rod and Exact-a-just™ cushioning on the blind end.

The bearing retainer plate is the same as the “E” dimension for 1-1/2” —6” bore sizes and the “XN” dimension for the 8” —14” bore sizes.

Rod end options are shown on page 72

• For double rod cylinders 1-1/2” thru 8” bore, add 1/2”; for 10 & 12” bore, add 1/4”; for 14” bore add 1/2”.

TABLE 2— Dimensions not affected by rod diameter

BORE IN	E	F	G	J	K	P	DT	EE NPTF	LB	NT—THD	SB BOLT	SN	SS•	ST	SU	SW	SX	SY	TN	TS	US
1.500	2.00	0.38	1.50	1.00	0.22	2.25	0.38	0.38	4.00	0.25—20	0.38	2.25	2.88	0.50	0.94	0.38	0.38	0.38	0.63	2.75	3.50
2.000	2.50	0.38	1.50	1.00	0.27	2.25	0.50	0.38	4.00	0.31—18	0.38	2.25	2.88	0.50	0.94	0.38	0.38	0.38	0.88	3.25	4.00
2.500	3.00	0.38	1.50	1.00	0.27	2.38	0.75	0.38	4.13	0.38—16	0.38	2.38	3.00	0.50	0.94	0.38	0.38	0.38	1.25	3.75	4.50
3.250	3.75	0.63	1.75	1.25	0.34	2.63	0.88	0.50	4.88	0.50—13	0.50	2.63	3.25	0.75	1.25	0.50	0.50	0.50	1.50	4.75	5.75
4.000	4.50	0.63	1.75	1.25	0.34	2.63	0.88	0.50	4.88	0.50—13	0.50	2.63	3.25	0.75	1.25	0.50	0.50	0.50	2.06	5.50	6.50
5.000	5.50	0.63	1.75	1.25	0.44	2.88	1.25	0.50	5.13	0.63—11	0.75	2.88	3.13	1.00	1.56	0.69	0.69	0.69	2.69	6.88	8.25
6.000	6.50	0.75	2.00	1.50	0.44	3.13	1.50	0.75	5.75	0.75—10	0.75	3.06	3.63	1.00	1.56	0.69	0.69	0.69	3.25	7.88	9.25
8.000	8.50	0.75	2.00	1.50	0.56	3.25	1.50	0.75	5.13	0.75—10	0.75	3.25	3.75	1.00	1.56	0.69	0.69	0.69	4.50	9.88	11.25
10.000	10.63	0.75	2.25	2.00	0.66	4.13	2.00	1.00	6.38	1.00—8	1.00	4.13	4.63	1.25	2.00	0.88	0.88	0.88	5.50	12.38	14.13
12.000	12.75	0.75	2.25	2.00	0.66	4.63	2.00	1.00	6.88	1.00—8	1.00	4.63	5.13	1.25	2.00	0.88	0.88	0.88	7.25	14.50	16.25
14.000	14.75	0.75	2.75	2.25	0.78	5.50	2.50	1.25	8.13	1.25—7	1.25	5.50	5.88	1.50	2.50	1.13	1.13	1.13	8.38	17.00	19.25

# Heavy Duty Pneumatic and Hydraulic NFPA Steel Cylinders

## POWERMASTER® PPT PNEUMATIC & PHT HYDRAULIC CYLINDERS

### TRUNNION MOUNTS

#### MT1 HEAD TRUNNION 1-1/2"–14"

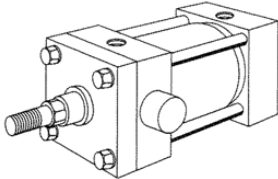

\*8" - 14" Bores only  
\*\*1-1/2" - 6" Bores only

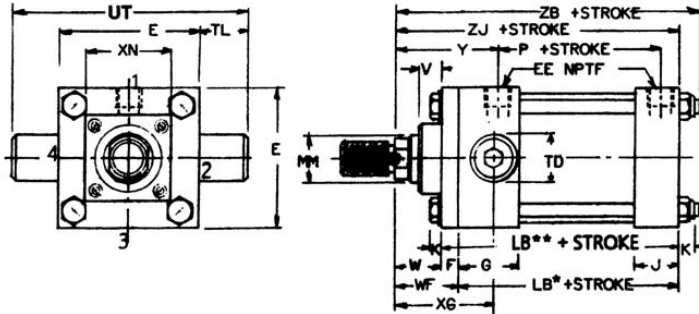

The "XG" and "XJ" dimensions for MT1 and MT2 mounts are longer than NFPA standard.

#### MT2 CAP TRUNNION 1-1/2"–14"

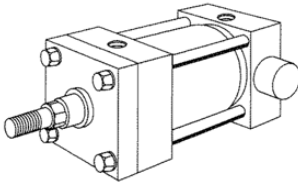

\*8" - 14" Bores only  
\*\*1-1/2" - 6" Bores only

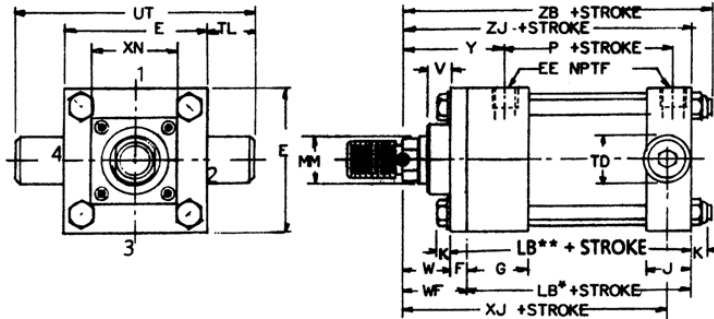

The "XG" and "XJ" dimensions for MT1 and MT2 mounts are longer than NFPA standard.

#### MT4 INTERMEDIATE FIXED TRUNNION 1-1/2"–14"

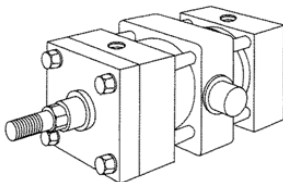

\*8" - 14" Bores only  
\*\*1-1/2" - 6" Bores only

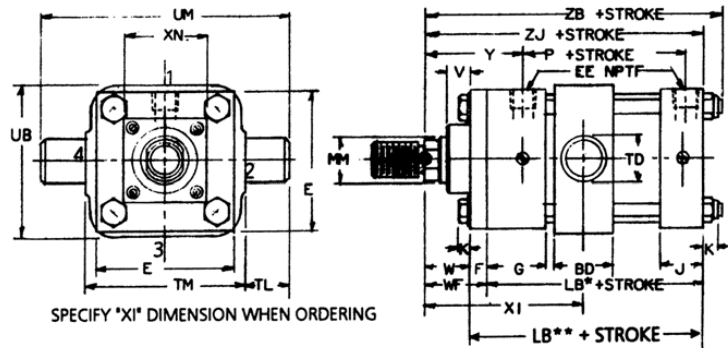

# Heavy Duty Pneumatic and Hydraulic NFPA Steel Cylinders

## POWERMASTER® PPT PNEUMATIC & PHT HYDRAULIC CYLINDERS

**TABLE 1** —Dimensions affected by rod diameter

BORE IN	MM ROD	V	W	WF	Y	XG	ZB	XI MIN	XJ	XN	ZJ
1.500	0.625	0.25	0.63		1.94	1.94	4.85	3.13	4.19		4.63
	†1.000	0.50	1.00		2.31	2.31	5.22	3.50	4.56		5.00
2.000	0.625	0.25	0.63		1.94	1.94	4.90	3.25	4.19		4.63
	1.000	0.50	1.00		2.31	2.31	5.27	3.63	4.56		5.00
2.500	†1.375	0.63	1.25		2.56	2.56	5.52	3.88	4.81		5.25
	0.625	0.25	0.63		1.94	1.94	5.02	3.25	4.31		4.75
3.250	1.000	0.50	1.00		2.31	2.31	5.40	3.63	4.69		5.13
	1.375	0.63	1.25		2.56	2.56	5.65	3.88	4.94		5.38
4.000	†1.750	0.75	1.50		2.81	2.81	5.90	4.13	5.19		5.63
	1.000	0.25	0.75		2.44	2.44	5.98	4.13	5.06		5.63
5.000	1.375	0.38	1.00		2.69	2.69	6.23	4.38	5.31		5.88
	1.750	0.50	1.25		2.94	2.94	6.48	4.63	5.56		6.13
6.000	†2.000	0.50	1.38		3.06	3.06	6.61	4.75	5.69		6.25
	1.000	0.25	0.75		2.44	2.44	5.98	4.13	5.06		5.63
7.000	1.375	0.38	1.00		2.69	2.69	6.23	4.38	5.31		5.88
	1.750	0.50	1.25		2.94	2.94	6.48	4.63	5.56		6.13
8.000	2.000	0.50	1.38		3.06	3.06	6.61	4.75	5.69		6.25
	2.500	0.63	1.63		3.31	3.31	6.86	5.00	5.94		6.50
9.000	1.000	0.25	0.75		2.44	2.44	6.32	4.13	5.31		5.88
	1.375	0.38	1.00		2.69	2.69	6.57	4.38	5.56		6.13
10.000	1.750	0.50	1.25		2.94	2.94	6.82	4.63	5.81		6.38
	2.000	0.50	1.38		3.06	3.06	6.94	4.75	5.94		6.50
11.000	2.500	0.63	1.63		3.31	3.31	7.19	5.00	6.19		6.75
	3.000	0.63	1.63		3.31	3.31	7.19	5.00	6.19		6.75
12.000	3.500	0.63	1.63		3.31	3.31	7.19	5.00	6.19		6.75
	1.375	0.25	0.88		2.81	2.81	7.07	4.88	5.94		6.63
13.000	1.750	0.38	1.13		3.06	3.06	7.32	5.13	6.19		6.88
	2.000	0.38	1.25		3.19	3.19	7.44	5.25	6.31		7.00
14.000	2.500	0.50	1.50		3.44	3.44	7.69	5.50	6.56		7.25
	3.000	0.50	1.50		3.44	3.44	7.69	5.50	6.56		7.25
15.000	3.500	0.50	1.50		3.44	3.44	7.69	5.50	6.56		7.25
	4.000	0.50	1.50		3.44	3.44	7.69	5.50	6.56		7.25
16.000	1.375	0.25		1.63	2.81	2.81	7.31	4.88	6.06	4.00	6.75
	1.750	0.38		1.88	3.06	3.06	7.56	5.13	6.44	4.00	7.00
17.000	2.000	0.38		2.00	3.19	3.19	7.69	5.25	6.56	4.00	7.13
	2.500	0.50		2.25	3.44	3.44	7.94	5.50	6.69	4.00	7.38
18.000	3.000	0.50		2.25	3.44	3.44	7.94	5.50	6.69	5.50	7.38
	3.500	0.50		2.25	3.44	3.44	7.94	5.50	6.69	5.50	7.38
19.000	4.000	0.50		2.25	3.44	3.44	7.94	5.50	6.69	5.50	7.38
	4.500	0.50		2.25	3.44	3.44	7.94	5.50	6.69	6.50	7.38
20.000	5.000	0.50		2.25	3.44	3.44	7.94	5.50	6.69	7.25	7.38
	5.500	0.50		2.25	3.44	3.44	7.94	5.50	6.69	7.25	7.38
21.000	1.750	0.38		1.88	3.13	3.13	8.91	5.63	7.25	4.00	8.25
	2.000	0.38		2.00	3.25	3.25	9.03	5.75	7.38	4.00	8.38
22.000	2.500	0.50		2.25	3.50	3.50	9.28	6.00	7.63	4.00	8.63
	3.000	0.50		2.25	3.50	3.50	9.28	6.00	7.63	5.50	8.63
23.000	3.500	0.50		2.25	3.50	3.50	9.28	6.00	7.63	5.50	8.63
	4.000	0.50		2.25	3.50	3.50	9.28	6.00	7.63	5.50	8.63
24.000	4.500	0.50		2.25	3.50	3.50	9.28	6.00	7.63	6.50	8.63
	5.000	0.50		2.25	3.50	3.50	9.28	6.00	7.63	6.50	8.63
25.000	5.500	0.50		2.25	3.50	3.50	9.28	6.00	7.63	6.50	8.63
	6.000	0.50		2.25	3.50	3.50	9.28	6.00	7.63	7.25	8.63
26.000	2.000	0.38		2.00	3.25	3.25	9.53	5.75	7.88	4.00	8.88
	2.500	0.50		2.25	3.50	3.50	9.78	6.00	8.13	4.00	9.13
27.000	3.000	0.50		2.25	3.50	3.50	9.78	6.00	8.13	5.50	9.13
	3.500	0.50		2.25	3.50	3.50	9.78	6.00	8.13	5.50	9.13
28.000	4.000	0.50		2.25	3.50	3.50	9.78	6.00	8.13	5.50	9.13
	4.500	0.50		2.25	3.50	3.50	9.78	6.00	8.13	6.50	9.13
29.000	5.000	0.50		2.25	3.50	3.50	9.78	6.00	8.13	6.50	9.13
	5.500	0.50		2.25	3.50	3.50	9.78	6.00	8.13	7.25	9.13
30.000	2.500	0.50		2.25	3.81	3.81	11.16	6.75	9.31	4.00	10.38
	3.000	0.50		2.25	3.81	3.81	11.16	6.75	9.31	5.50	10.38
31.000	3.500	0.50		2.25	3.81	3.81	11.16	6.75	9.31	5.50	10.38
	4.000	0.50		2.25	3.81	3.81	11.16	6.75	9.31	5.50	10.38
32.000	4.500	0.50		2.25	3.81	3.81	11.16	6.75	9.31	6.50	10.38
	5.000	0.50		2.25	3.81	3.81	11.16	6.75	9.31	6.50	10.38
33.000	5.500	0.50		2.25	3.81	3.81	11.16	6.75	9.31	6.50	10.38
	6.000	0.50		2.25	3.81	3.81	11.16	6.75	9.31	7.25	10.38

### TRUNNION MOUNTS

All trunnion mounted cylinders need a provision on both ends for pivoting. These types of cylinders are designed to carry shear loads and the trunnion and pivot pins should be carried by bearings that rigidly held and closely fit for the entire length of the pin.

Head or rod end trunnions should be carefully applied to either short strokes or to applications where the weight of the cylinder falls vertically below the pin.

### NOTES:

† Available with fixed non-adjustable cushion on the rod end and standard Exact-a-just™ cushion on the cap end only.

Specify the “XI” dimension when ordering MT4 Intermediate Fixed Trunnion mounts. If not specified, the trunnion will be located at the center of the tube.

The “XG” and “XJ” dimensions for MT1 and MT2 mounts are not NFPA Standard.

The bearing retainer plate is the same as the “E” dimension for bore sizes 1-1/2”—6” and the “XN” dimension for 8”—14” bore sizes.

For rod end options see pg 72.

**TABLE 2** — Dimensions not affected by rod diameter

BORE SIZE	E	F	G	J	K	P	BD	EE NPTF	LB	*TD +0.000 -0.002	TL	TM	UB	UM	UT
1.50"	2.00	0.38	1.50	1.00	0.22	2.25	1.25	0.38	4.00	1.000	1.00	2.50	2.25	4.50	4.00
2.00"	2.50	0.38	1.50	1.00	0.27	2.25	1.50	0.38	4.00	1.000	1.00	3.00	2.75	5.00	4.50
2.50"	3.00	0.38	1.50	1.00	0.27	2.38	1.50	0.38	4.13	1.000	1.00	3.50	3.25	5.50	5.00
3.25"	3.75	0.63	1.75	1.25	0.34	2.63	2.00	0.50	4.88	1.000	1.00	4.50	4.25	6.50	5.75
4.00"	4.50	0.63	1.75	1.25	0.34	2.63	2.00	0.50	4.88	1.000	1.00	5.25	5.00	7.25	6.50
5.00"	5.50	0.63	1.75	1.25	0.44	2.88	2.00	0.50	5.13	1.00	1.00	6.25	6.00	8.25	7.50
												6.75		8.75	
6.00"	6.50	0.75	2.00	1.50	0.44	3.13	2.50	0.75	5.75	1.375	1.38	7.63	7.38	10.38	9.25
8.00"	8.50	0.75	2.00	1.50	0.56	3.25	2.50	0.75	5.13	1.375	1.38	9.75	9.50	12.50	11.25
10.00"	10.63	0.75	2.25	2.00	0.66	4.13	3.00	1.00	6.38	1.750	1.75	12.00	11.75	15.50	14.13
12.00"	12.75	0.75	2.25	2.00	0.66	4.63	3.00	1.00	6.88	1.750	1.75	14.00	13.75	17.50	16.25
14.00"	14.75	0.75	2.75	2.25	0.78	5.50	3.50	1.25	8.13	2.000	2.00	16.25	16.00	20.25	18.75

Air PP  
Oil PH

# Heavy Duty Pneumatic and Hydraulic NFPA Steel Cylinders

## POWERMASTER® PPT PNEUMATIC & PHT HYDRAULIC CYLINDERS

### MX1 TIE RODS EXTENDED BOTH ENDS

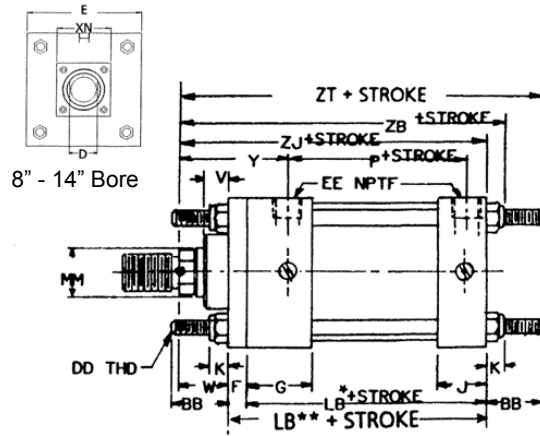
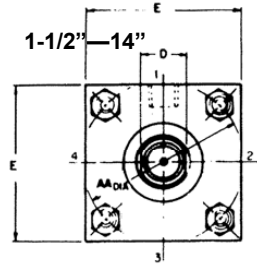
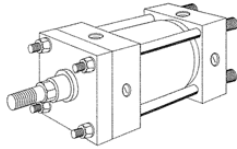

\*8" - 14" Bores only (XN See above)  
 \*\*1-1/2" - 6" Bores only

### MX2 TIE RODS EXTENDED CAP END ONLY

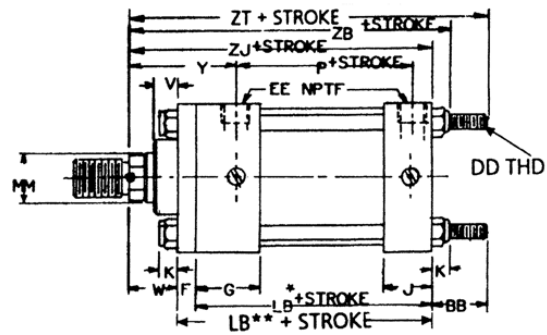
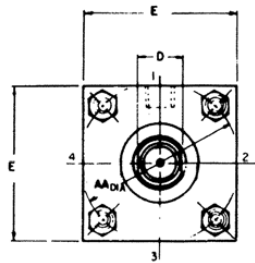
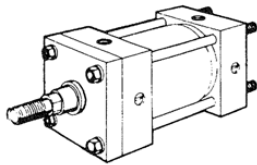

\*8" - 14" Bores only (XN See above)  
 \*\*1-1/2" - 6" Bores only

### MX3 TIE RODS EXTENDED HEAD END ONLY

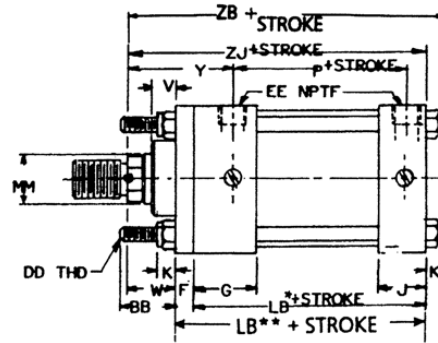
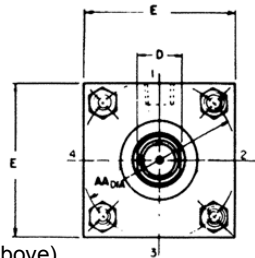
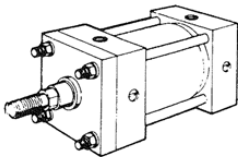

\*8" - 14" Bores only (XN See above)  
 \*\*1-1/2" - 6" Bores only

### MX4 TIE RODS EXTENDED HEAD END ONLY

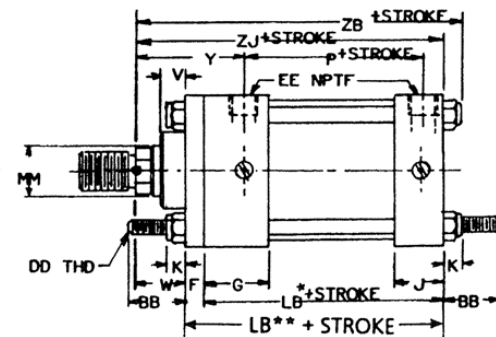
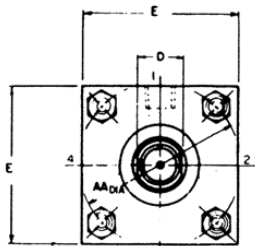
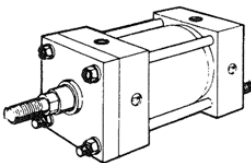

\*8" - 14" Bores only (XN See above)  
 \*\*1-1/2" - 6" Bores only



# Heavy Duty Pneumatic and Hydraulic NFPA Steel Cylinders

## POWERMASTER® PPT PNEUMATIC & PHT HYDRAULIC CYLINDERS

TABLE 1—Dimensions affected by rod diameter

BORE IN	MM ROD	V	W	WF	Y	XN	ZB	ZJ	ZT
1.500	0.625	0.25	0.63		1.94		4.85	4.63	5.63
	† 1.000	0.50	1.00		2.31		5.22	5.00	6.00
2.000	0.625	0.25	0.63		1.94		4.90	4.63	5.75
	1.000	0.50	1.00		2.31		5.27	5.00	6.13
2.500	† 1.375	0.63	1.25		2.56		5.52	5.25	6.38
	0.625	0.25	0.63		1.94		5.02	4.75	5.88
3.250	1.000	0.50	1.00		2.31		5.40	5.13	6.25
	1.375	0.63	1.25		2.56		5.65	5.38	6.50
	† 1.750	0.75	1.50		2.81		5.90	5.63	6.75
	1.000	0.25	0.75		2.44		5.98	5.63	7.00
4.000	1.375	0.38	1.00		2.69		6.23	5.88	7.25
	1.750	0.50	1.25		2.94		6.48	6.13	7.50
	† 2.000	0.50	1.38		3.06		6.61	6.25	7.63
	1.000	0.25	0.75		2.44		5.98	5.63	7.00
5.000	1.375	0.38	1.00		2.69		6.23	5.88	7.25
	1.750	0.50	1.25		2.94		6.48	6.13	7.50
	2.000	0.50	1.38		3.06		6.61	6.25	7.63
	2.500	0.63	1.63		3.31		6.86	6.50	7.88
6.000	1.000	0.25	0.75		2.44		6.32	5.88	7.69
	1.375	0.38	1.00		2.69		6.57	6.13	7.94
	1.750	0.50	1.25		2.94		6.82	6.38	8.06
	2.000	0.50	1.38		3.06		6.94	6.50	8.31
8.000	2.500	0.63	1.63		3.31		7.19	6.75	8.56
	3.000	0.63	1.63		3.31		7.19	6.75	8.56
	3.500	0.63	1.63		3.31		7.19	6.75	8.56
	1.375	0.25	0.88		2.81		7.07	6.63	8.44
10.000	1.750	0.38	1.13		3.06		7.32	6.88	8.69
	2.000	0.38	1.25		3.19		7.44	7.00	8.81
	2.500	0.50	1.50		3.44		7.69	7.25	9.06
	3.000	0.50	1.50		3.44		7.69	7.25	9.06
12.000	3.500	0.50	1.50		3.44		7.69	7.25	9.06
	4.000	0.50	1.50		3.44		7.69	7.25	9.06
	1.375	0.25		1.63	2.81	4.00	7.31	6.75	9.06
	1.750	0.38		1.88	3.06	4.00	7.56	7.00	9.31
14.000	2.000	0.38		2.00	3.19	4.00	7.69	7.13	9.44
	2.500	0.50		2.25	3.44	4.00	7.94	7.38	9.69
	3.000	0.50		2.25	3.44	5.50	7.94	7.38	9.69
	3.500	0.50		2.25	3.44	5.50	7.94	7.38	9.69
16.000	4.000	0.50		2.25	3.44	5.50	7.94	7.38	9.69
	4.500	0.50		2.25	3.44	6.50	7.94	7.38	9.69
	5.000	0.50		2.25	3.44	6.50	7.94	7.38	9.69
	5.500	0.50		2.25	3.44	7.25	7.94	7.38	9.69
18.000	2.500	0.50		2.25	3.50	7.25	7.94	7.38	9.69
	3.000	0.50		1.88	3.13	4.00	8.91	8.25	10.94
	3.500	0.50		2.00	3.25	4.00	9.03	8.38	11.06
	4.000	0.50		2.25	3.50	4.00	9.28	8.63	11.31
20.000	4.500	0.50		2.25	3.50	5.50	9.28	8.63	11.31
	5.000	0.50		2.25	3.50	5.50	9.28	8.63	11.31
	5.500	0.50		2.25	3.50	5.50	9.28	8.63	11.31
	6.000	0.50		2.25	3.50	6.50	9.28	8.63	11.31
22.000	6.500	0.50		2.25	3.50	7.25	9.28	8.63	11.31
	7.000	0.50		2.00	3.25	4.00	9.53	8.88	11.56
	7.500	0.50		2.25	3.50	4.00	9.78	9.13	11.81
	8.000	0.50		2.25	3.50	5.50	9.78	9.13	11.81
24.000	8.500	0.50		2.25	3.50	5.50	9.78	9.13	11.81
	9.000	0.50		2.25	3.50	6.50	9.78	9.13	11.81
	9.500	0.50		2.25	3.50	6.50	9.78	9.13	11.81
	10.000	0.50		2.25	3.50	7.25	9.78	9.13	11.81
26.000	10.500	0.50		2.25	3.81	4.00	11.16	10.38	13.56
	11.000	0.50		2.25	3.81	5.50	11.16	10.38	13.56
	11.500	0.50		2.25	3.81	5.50	11.16	10.38	13.56
	12.000	0.50		2.25	3.81	6.50	11.16	10.38	13.56
28.000	12.500	0.50		2.25	3.81	6.50	11.16	10.38	13.56
	13.000	0.50		2.25	3.81	6.50	11.16	10.38	13.56
	13.500	0.50		2.25	3.81	6.50	11.16	10.38	13.56
	14.000	0.50		2.25	3.81	7.25	11.16	10.38	13.56

### EXTENDED TIE ROD MOUNTS

Tie rod and flange mounts are basically the same except that the tie rods are extended and used to mount the cylinder. To prevent misalignment, sagging, or binding of the cylinder when long strokes are required, the free end of the cylinder should be supported. For thrust load applications, blind or cap end tie rod extensions are best. For tension load applications, rod or head end extensions are best. Tie rod mounts are suited for many applications however, it should be noted that they are not as rigid as the flange mount.

### NOTES:

† Available with fixed non-adjustable cushion on the rod end and standard Exact-a-just™ cushion on the cap only.

The bearing retainer plate is the same as the “E” dimension for 1-1/2”–6” bore sizes and the “XN” dimension for the 8”–14” bore sizes.

For rod end options see page 72.

TABLE 2— Dimensions not affected by rod diameter

BORE IN	E	F	G	J	K	P	AA	BB	DD THD	EE NPTF	LB
1.500	2.00	0.38	1.50	1.00	0.22	2.25	2.02	1.00	0.25–28	0.38	4.00
2.000	2.50	0.38	1.50	1.00	0.27	2.25	2.60	1.13	0.31–24	0.38	4.00
2.500	3.00	0.38	1.50	1.00	0.27	2.38	3.10	1.13	0.31–24	0.38	4.13
3.250	3.75	0.63	1.75	1.25	0.34	2.63	3.90	1.38	0.38–24	0.50	4.88
4.000	4.50	0.63	1.75	1.25	0.34	2.63	4.70	1.38	0.38–24	0.50	4.88
5.000	5.50	0.63	1.75	1.25	0.44	2.88	5.80	1.81	0.50–20	0.50	5.13
6.000	6.50	0.75	2.00	1.50	0.44	3.13	6.90	1.81	0.50–20	0.75	5.75
8.000	8.50	0.75	2.00	1.50	0.56	3.25	9.10	2.31	0.63–18	0.75	5.13
10.000	10.63	0.75	2.25	2.00	0.66	4.13	11.20	2.69	0.75–16	1.00	6.38
12.000	12.75	0.75	2.25	2.00	0.66	4.63	13.30	2.69	0.75–16	1.00	6.88
14.000	14.75	0.75	2.75	2.25	0.78	5.50	15.40	3.19	0.88–14	1.25	8.13

\* For these or larger size rods on 8” and 10” bores, consult factory before ordering.

# Heavy Duty Pneumatic and Hydraulic NFPA Steel Cylinders

## POWERMASTER® PPT PNEUMATIC & PHT HYDRAULIC CYLINDERS

### HOW TO ORDER

EXAMPLES (A) 2 x 10 C-MP1-PHT-C;  
5/8" Rod, 7/16" - 20 M. Threads

(B) 4 x 36 Effective Stroke, C-MP1-PHT-C 1-3/8" rod, 1"-14 male Threads, 4" Stop Tube "A" = STD + 1", "W" = STD + 1/2", Epoxy Paint Proximity Switch @ Location #4 Head and Cap

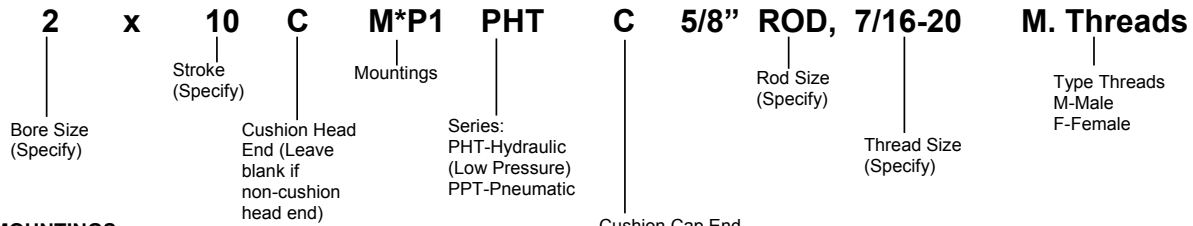

#### MOUNTINGS

- Head Square (8"-- 14") ME3
- Cap Screws (8"-- 14") ME4
- Head Rectangular Flange (1-1/2"-- 6") MF1
- Cap Rectangular Flange (1-1/2"-- 6") MF2
- Head Square Flange (1-1/2"-- 6") MF5
- Cap Square Flange (1-1/2"-- 6") MF6
- Cap Fixed Clevis MP1
- Cap Detachable Clevis MP2
- Cap Fixed Eye MP3
- Cap Detachable Eye MP4
- Side End Angles MS1
- Side Lug MS2
- Center Line Lug MS3
- Side Tap MS4
- Side End Lug MS7
- Head End Trunnion MT1
- Cap End Trunnion MT2
- Intermediate Fixed Trunnion (specify XI) MT4
- Universal Clevis MU3
- Tie Rod Mounting MX0, 1, 2, 3, 4

\* Double Rod End (Example MDE3)  
(Specify only when required, available in most mountings. 1-1/2, 2, 2-1/2 bore cylinders with the maximum oversize rod and head cushion have no head cushion adjustment or check valve bypass. These models are not recommended for double end application.)

#### OPTIONS

- Seals-- Standard, Viton, other
- Piston Rod Stud
- Rod Extension ("W" Dimension)
- Thread Extension ("A" Dimension)
- Stop Tube (Specify Effective Stroke) + inches of stop tube
- Piston Rod Material (Stainless Steel)
- Port Location if other than standard #1 location
- Cushion Location if other than standard #2 location
- Water Service
- Mixed Mountings
- Epoxy Paint
- Additional Ports
- SAE O-ring Straight Thread Ports
- Additional Cushion Adjustment Screws
- Oversized Ports
- Stroke Adjuster in Cap
- Moveable Center Trunnion (MT4)
- Special Items as Required

### \*PRESSURE RATINGS FOR DOUBLE ROD END POWERMASTER CYLINDERS

BORE SIZE	ROD SIZE	CUSHION ROD END OR NON-CUSHION	CUSHION BOTH ENDS OR EXT.	BORE SIZE	ROD SIZE	CUSHION ROD END OR NON-CUSHION	CUSHION BOTH ENDS OR EXT.	
1.50	.625	1,000 PSI	750 PSI	8.00	1.38	200 PSI	Not Available	
	1.00	1,000 PSI	1,000 PSI		1.75	500 PSI	450 PSI	
2.00	.625	800 PSI	450 PSI		2.00	500 PSI	500 PSI	
	1.00	1,000 PSI	500 PSI		2.50	500 PSI	500 PSI	
	1.38	1,000 PSI	1,000 PSI		3.00	500 PSI	500 PSI	
2.50	.625	500 PSI	250 PSI		3.50	500 PSI	500 PSI	
	1.00	1,000 PSI	500 PSI		4.00	500 PSI	500 PSI	
	1.38	1,000 PSI	1,000 PSI		10.00	1.75	250 PSI	Not Available
	1.75	1,000 PSI	1,000 PSI			2.00	400 PSI	300 PSI
3.25	1.00	500 PSI	Not Available			2.50	400 PSI	400 PSI
	1.38	1,000 PSI	1,000 PSI	3.00		400 PSI	400 PSI	
	2.00	1,000 PSI	1,000 PSI	3.50		400 PSI	400 PSI	
4.00	1.00	400 PSI	Not Available	4.00		400 PSI	400 PSI	
	1.38	1,000 PSI	1,000 PSI	12.00		2.00	175 PSI	Not Available
	1.75	1,000 PSI	1,000 PSI			2.50	250 PSI	250 PSI
	2.00	1,000 PSI	1,000 PSI			3.00	250 PSI	250 PSI
	5.00	2.50	1,000 PSI			1,000 PSI	3.50	250 PSI
1.00		250 PSI	Not Available		4.00	250 PSI	250 PSI	
1.38		750 PSI	750 PSI		14.00	2.50	150 PSI	Not Available
1.75	750 PSI	750 PSI	3.00			250 PSI	250 PSI	
2.00	750 PSI	750 PSI	3.50			250 PSI	250 PSI	
2.50	750 PSI	750 PSI	4.00			250 PSI	250 PSI	
3.00	750 PSI	750 PSI	6.00			1.38	250 PSI	Not Available
3.50	750 PSI	750 PSI		1.75		750 PSI	750 PSI	
6.00	2.00	750 PSI		750 PSI	2.00	750 PSI	750 PSI	
	2.50	675 PSI		675 PSI	2.50	750 PSI	750 PSI	
	3.00	750 PSI	750 PSI	3.00	750 PSI	750 PSI		
	3.50	750 PSI	750 PSI	4.00	750 PSI	750 PSI		

# Heavy Duty Pneumatic and Hydraulic NFPA Steel Cylinders

## POWERMASTER® PPT PNEUMATIC & PHT HYDRAULIC CYLINDERS

### 1-1/2" — 14" BORES

#### INSTALLATION AND SERVICE INFORMATION

##### Approximate Uncrated Powermaster Weights (lbs.)\* (Air & Hydraulic Models)

CYLINDER BORE	1-1/2"	2	2-1/2	3-1/4	4	5	6	8	10	12	14
ZERO STROKE	5	7	12	20	30	45	70	100	200	300	490
ADD PER INCH OF STROKE	.3	.4	.6	.8	.9	1.0	1.5	2.0	2.5	4.0	4.5

\*Weights based on standard (first) rod sizes.

**WARNING—** Read and follow warnings and directions as listed on the inside back cover of this catalog prior to performing any service or installation.

**INSTALLATION—** For outline dimensions and other considerations in mounting the PowerMaster, see pages 11 - 24. Before plumbing the cylinder, all lines in the system should be flushed to remove any contamination. To prevent corrosion and accumulation of foreign matter in the air cylinder, a 10 MICRON or better filter should be installed in the supply line to the cylinder control valve.

A very important consideration in mounting the PowerMaster cylinder is keeping the cylinder thrust as close as possible to the centerline of the piston rod and free of misalignment or side loading. Off-center thrust or side loads decrease the normal life of the rod bearing and seals and can cause binding in the cylinder or linkage. Forcing rod, clevis pins, or mounting bolts into position indicates that the cylinder is not properly aligned, and permanent damage may result for such installation.

**Side End Angles (MS1), Side Lugs (MS2), Centerline Lugs (MS3) and Side End Lugs (MS7):** After a cylinder with one of these mountings has been aligned, key or pin it to its support. Properly located shear keys or pins will absorb the major portion of the shear load that can develop in the bolts that fasten the cylinder to its support. Always use high-tensile steel bolts to fasten the cylinder.

**Head Rectangular Flange (MF1), Cap Rectangular Flange (MF2), Head Square Flange (MF5 & ME3), and Cap Square Flange (MF6 & ME4):** A flange-mounted cylinder can be centered by using the gland in the cylinder head as a pilot. After mounting and alignment, the cylinder should be dowelled to its supports to keep it from shifting. For installations that use maximum operating pressures or have high shock loads, a square flange is recommended.

**Head Trunnion (MT1), Cap Trunnion (MT2), and Intermediate Fixed or Movable Trunnion (MT4):** Install a trunnion-mounted cylinder in rigid and accurately aligned pillow blocks. These blocks should be well lubricated at all times. Since trunnion pins are designed for shear loads only, provide linkage with a suitable pivot for connection to the rod end of the cylinder.

##### STANDARD SPECIFICATIONS

**Duty:** 250 psi Pneumatic, 250-1500 psi Hydraulic (see chart)  
**Standards:** Meet or exceeds all J.I.C. and NFPA requirements  
**Bore Sizes:** 1-1/2" — 14" (standard)  
**Piston Rods:** 5/8" — 5-1/2" (standard)  
**Mountings:** 21 standard NFPA mountings.  
**Temperature Range:** -65°F to +200°F (Buna N Standard seals)  
 Optional Viton seals for -15°F to +400°F and many fluids which require chemical resistance.

##### HYDRAULIC OPERATING PRESSURES BY CYLINDER BORE SIZES

BORE SIZE	1-1/2 2	2-1/2* 3-1/4	4	5	6	8	10	12	14
MAX. PSI, MAX. DUTY, SEVERE SERVICE	1,500	1,500	1,000	750	750	500	400	250	250

\* for 5/8" rod, 1000 psi

**Fixed Clevis (MP1), Detachable Clevis (MP2) and Universal Clevis (MU3):** In the installation of a clevis-mounted cylinder, the centerline of the pivot pin in the rod end linkage must be parallel with the centerline of the clevis pin in the cap end of the cylinder. A universal clevis mount automatically compensates for 5 to 10 degrees of misalignment in any direction. Never allow the cylinder head or cap to stop the piston at the end of its stroke. Either provide external stops to prevent the piston from bottoming or use a cylinder with built-in cushioning. A cushioned cylinder will stop the piston just before it reaches the end of its stroke. Under certain conditions of load, external stops may be required to supplement the cylinder cushioning.

**OPERATION—** The standard Powermaster pneumatic cylinder has a maximum operating pressure of 250 psi, and the hydraulic cylinder a maximum of 250 - 1500 psi at a temperature range of -65°F to +200°F. For operating temperatures above or below this range, cylinders with special packing and seals are required. Air pressure supplied to the cap-end port moves the piston rod to its extended position. Pressure supplied to the head end port moves the piston rod to its retraced position. See page 62 for forces developed by each cylinder.

**ADJUSTMENT—** A noncushioned cylinder requires no further adjustment after it has been installed and properly aligned. A cushioned cylinder, after installation and alignment, must be adjusted to obtain the degree of cushioning desired. An adjustment is provided by a screw-type needle and check valve in either or both ends of the cylinder. This Exact-a-just™ valve controls the rate at which trapped air or fluid is allowed to meter from the end of the cylinder when the piston is near the end of its stroke. Turn the needle valve clockwise to increase the amount of cushioning and counter-clockwise to decrease cushioning. To obtain the most effective cushioning, final adjustment must be made while the cylinder is operating under normal conditions at normal operating pressure.

# Heavy Duty Pneumatic and Hydraulic NFPA Steel Cylinders

## POWERMASTER® PPT PNEUMATIC & PHT HYDRAULIC CYLINDERS

### 1-1/2" — 14" BORES — MAJOR REPAIR, MAINTENANCE & TESTING

#### GENERAL MAINTENANCE AND REPAIR RECOMMENDATIONS

Maintenance periods should be scheduled in accordance with frequency of use and working environment of the cylinder. All cylinders must be visually inspected for wear and given an "in system" operating performance and leakage test at least once a year. If these visual observations indicate cylinder repair is required, the cylinder must be removed, repaired and tested. A major overhaul is recommended at one million cycles. However, where frequency of use is such that it would require more than two years to obtain one million cycles, the cylinder must be overhauled at the two year period. When it is determined that the cylinder requires a major repair as a result of the one million cycles, one year routine inspection, or the two year service period has elapsed, the device must be disassembled, cleaned, inspected, parts replaced as required, rebuilt and tested for leakage, and proper operation prior to installation. Refer to MAJOR REPAIR, MAINTENANCE INSTRUCTION, and TEST PROCEDURES.

#### MAJOR REPAIR AND MAINTENANCE INSTRUCTION.

Always exhaust or drain the pressure from the system before performing any service work. Disconnect lines from head and cap ports of cylinder. Completely disassemble the cylinder using the exploded and assembly views as reference. No special tools are required except internal snap ring pliers. The piston rod assembly consisting of rod, piston and head cushion bushing (where used) are torque and secured at the factory and are not to be disassembled (cylinders built prior to 1985 utilized piston nut). After disassembling the cylinder, wash all metal parts in a non-flammable solvent. Rinse each part thoroughly and blow dry with a low pressure air jet. Arrange the parts on a clean surface. Examine each part carefully. Replace all rubber parts and other worn or damaged parts. The use of REPAIR KITS is strongly recommended. Particular attention should be given to the rod bearing (5a) since cylinder leakage can result from a worn bearing. A scored or rough rod bearing might damage the piston rod and subsequently, the rod packing. Rod cartridge kits are available with or without the rod bearing.

An excellent feature of the POWERMASTER Cylinder is easy replacement of the rod cartridge (5) without loosening the tie rods. On most cylinders with the bore sizes from 1-1/2" - 6 inches, remove the screws and washers (1 & 2) and retainer plate (4a). For all cylinders with bore sizes 8" - 14", remove screws (3) and retainer plate (4b). The rod cartridge is easily removed from the cylinder head. To facilitate removal, a screwdriver can be used to pry in the external groove.

#### REASSEMBLY

The procedure for reassembly is essentially the reverse of disassembly. However, the following exceptions should be noted:

- All O-rings should be well coated with Cylinder Lube grease for air cylinders or the hydraulic fluid used in the application for hydraulic cylinders, as they are installed in their respective grooves and prior to reassembly with the mating part. Care must be taken when assembling O-rings and packings that they are not damaged, as this will cause leakage.
- Reassemble the cylinder using the exploded and assembly views as reference. **Pneumatic Only:** As the

assembly proceeds, lubricate the piston seals, cushion seals, rod seal, tube and tube seals with Cylinder Lube grease. Pay particular attention to the installation of the cushion kit (ref. 11 & 19) to insure that the tapered rubber surface marked "THIS SIDE UP" faces to the inside (piston side) of the cylinder.

**Hydraulic Only:** Lubricate inside diameter of cylinder tube and piston rod, plus all seals, with hydraulic fluid used in cylinder application. The hydraulic fluid specified for use in the cylinder is the only lubricant to be used in assembly.

- Tie rod threads should be well lubricated to allow tightening the nuts evenly for proper pre-stressing. To avoid twisting of the tie rods during tightening, hold with vise grip or clamp. To assure equal pre-stressing of the tie rods, first turn on nuts even and snug to align assembly, then the nuts are to be tightened alternately. For proper tie rod pre-stressing, they should be torque as recommended. The specific torque value is determined by the diameter of the tie rod. For lubricated tie-rod threads, these torque values are:

CYL. BORE SIZE	TIE ROD DIA.	TORQUE-LUBRICATED POUNDS—FOOT
1-1/2"	1/4"	4.5
2"	5/16"	9
2-1/2"	5/16"	12
3-1/4"	3/8"	23
4"	3/8"	22
5" & 6"	1/2"	45
8"	5/8"	90

**TESTING:** After the cylinder has been completely reassembled, it should be tested, either on a test bench or in the regular installation.

**TEST PROCEDURES:** (see maximum psi/style). The cylinder should be tested for cushioning, travel and leakage.

#### A. Cushioning (if applicable)

- Turn both cushioning screws clockwise all the way in.
- Cycle cylinder a few times by alternating supply pressure to head & cap ports.
- Apply supply pressure to the head port. Rod should retract, decelerate and may stop before completion of stroke.
- Apply supply pressure to the cap port. Rod should extend, decelerate and may stop before completion of stroke.

#### B. Travel and Leakage

- Turn the cushioning screws counterclockwise one (1) full turn.
- Apply supply pressure to the head port. Rod should retract smoothly without binding. Cylinder should retract, has less cushioning and make full stroke + or - .062". Check leakage at cap port, 30cc/min. leakage permitted. Check leakage around rod seal. No leakage permitted.
- Apply supply pressure to the cap port. Rod should extend smoothly without binding. Cylinder should have less cushioning and make full stroke + or - .062". Check leakage at head port, 30cc/min. leakage permitted.
- Return piston rod to retract position by applying supply pressure to head port. Remove supply pressure and install cylinder in service if satisfactory.

#### CUSHION ADJUSTMENT

Turn the needle valve clockwise to increase the amount of cushioning and counter-clockwise to decrease cushioning. To obtain the most effective cushioning, final adjustment must be made while the cylinder is operating under normal conditions at normal operating pressure.

# Heavy Duty Pneumatic and Hydraulic NFPA Steel Cylinders

POWERMASTER® PPT PNEUMATIC & PHT HYDRAULIC CYLINDERS

## POWERMASTER PPT PNEUMATIC CYLINDERS 1-1/2" — 14" BORES

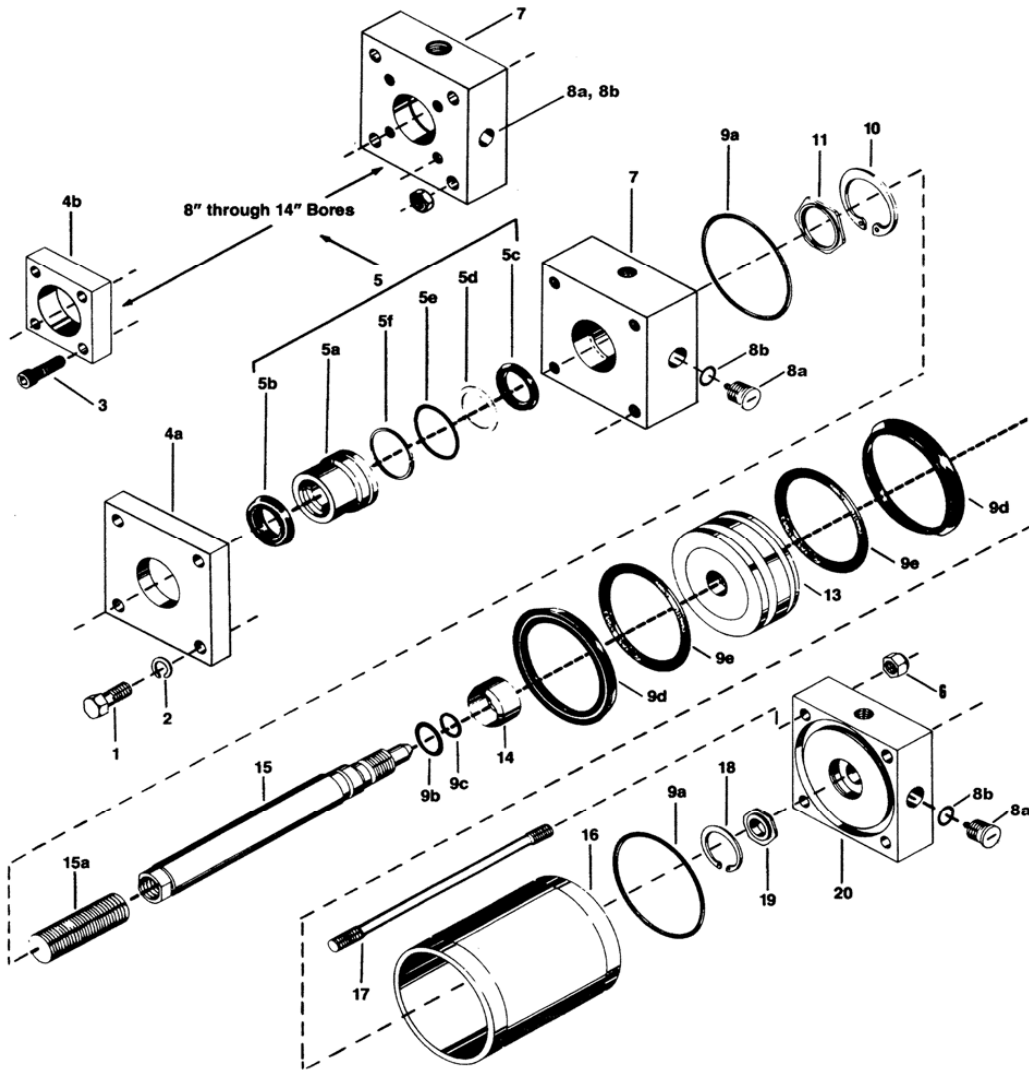

1-1/2" through 6" bores

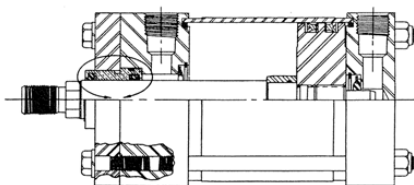

8" through 14" bores

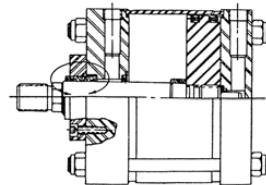



# Heavy Duty Pneumatic and Hydraulic NFPA Steel Cylinders

## POWERMASTER® PPT PNEUMATIC & PHT HYDRAULIC CYLINDERS

### SERVICE INFORMATION — POWERMASTER PPT PNEUMATIC, 1-1/2"—14" BORES

REF.	DESCRIPTION	CUSHIONED BOTH ENDS	CUSHIONED HEAD ONLY	CUSHIONED CAP ONLY	NON-CUSHIONED
1	SCREW, Cap (1-1/2"-6" bores)	4	4	4	4
2	WASHER, Lock (1-1/2"-6" bores)	4	4	4	4
3	SCREW, Socket Head Cap (8"-14" bores)	4	4	4	4
4a	PLATE, Retainer (1-1/2"-6" bores)	1	1	1	1
4b	PLATE, Retainer (8"-14" bores)	1	1	1	1
5*	CARTRIDGE, Rod Kit	1	1	1	1
5a	BEARING, Rod	1	1	1	1
5b	WIPER, Rod	1	1	1	1
5c	PACKING, "U" Rod	1	1	1	1
5d	O-RING, Backup	1	1	1	1
5e	O-RING, Rod Bearing	1	1	1	1
5f	RING, Backup	1	1	1	1
6	NUT, Tie Rod Lock	†	†	†	†
7	HEAD	1	1	1	1
8*	CUSHION, Needle Valve Kit	2	1	1	-
8a	VALVE, Exact-a-just™ Needle & Check (includes Ref. 8)	2	1	1	-
8b	O-RING, Needle Valve	2	1	1	-
9*	PISTON & TUBE Seal Kit	1	1	1	1
9a	O-RING, End Cover	2	2	2	2
9b	O-RING, Head Cushion Bushing	1	1	1	1
9c	O-RING, Piston Bearing	1	1	1	1
9d	SEAL, Piston	2	2	2	2
9e	RING, Piston Backup	2	2	2	2
10	RING, Head Cushion Retaining	1	1	1	1
11	SEAL, Head Cushion Kit	1	1	-	-
12	NUT, Piston Retaining (Not shown - not used after 1984)	1	1	1	1
13	PISTON				
14	BUSHING, Head Cushion	1	1	-	-
15	ROD, Female Piston	1	1	1	1
15a	ADAPTER, Male Piston Rod (when required)	1	1	1	1
16	TUBE, Cylinder	1	1	1	1
17	TIE ROD	4	4	4	4
18	RING, Cap Cushion Retaining	1	-	1	-
19*	SEAL, Cap Cushion Kit	1	-	1	-
20	CAP	1	1	1	1

\*Recommended spare parts to be retained in stock at all times. See "REPAIR KITS" below.

† On 8" — 14" bores, 8 are always required. On 1-1/2"—6" bores, 4 are normally required, but may sometimes replace Ref. No. 1 & 2 on some mounting styles.

### REPAIR KITS

Repair parts included in the following repair kits are available only in kit form. Kits should be ordered by kit part numbers plus cylinder part number when possible. Some kits may have an excess of parts not used in some cylinder models. Discard these parts or keep for later use. Other parts not included in repair kits must be ordered separately by reference number, description, and cylinder part number.

Rod Cartridge Kit (with Rod Bearing)			Rod Seal Kit (less Rod Bearing)		Head Cushion Seal
Rod Diameter	Buna N With Urethane Rod Wiper (std.) Part Number	Viton Part Number	Buna N With Urethane Rod Wiper (std.) Part Number	Viton Part Number	Buna N* Part Number
0.63"	R433023506	R433023936	R433014982	R433023935	R432029151
1.00"	R433023510	R433014756	R433014984	R433023941	R433023150
1.38"	R433014766	R433023946	R433014986	R433023945	R433015596
1.75"	R433023515	R433023952	R433014988	R433023951	R433022387
2.00"	R433023519	R433023958	R433014990	R433023957	R433022388
2.50"	R433023523	R433023964	R433024068	R433023963	R433023465
3.00"	R433023526	R433014768	R433024071	R433023969	
3.50"	R433014844	R433074988	R433074775	R433024261	
4.00"	R433014682	R433021263	R433014976		
4.50"	R433014684		R433014978	R433024269	
5.00"	R433014686	R433024267	R433014980		
5.50"	R433014688				
Includes Ref. items: 5a, 5b, 5c, 5d, 5e & 5f			Includes Ref. items 5b, 5c, 5d, 5e & 5f		* Buna N rubber For high-temp. opera- consult the factory.
Bore Size	Piston & Tube Seal Kit		Cap Cushion Seal		Cushion Needle Valve Assemblies (Exact-a-just™)
	BUNA N Part Number	VITON Part Number	BUNA N* Part Number		
1.50"	R433023971	R433023977	R433015593		Part Number
2.00"	R433023981	R433023987	R433015593		
2.50"	R433023993	R433023997	R433015593		Bore Sizes
3.25"	R433024002	R433024009	R433015594		
4.00"	R433024012	R433024018	R433015594		R433015236 1.5", 2", 2.5" Buna- R433016568 3.25", 4", 5" Buna- R433023258 6" thru 14" Buna-N
5.00"	R433024022	R433024027	R433015594		
6.00"	R433024031	R433024037	R433015595		R433072609 1.5", 2", 2.5" Viton R433074773 3.25", 4", 5" Viton R433023256 6" thru 14" Viton
8.00"	R433024041	R433024043	R433015595		
10.00"	R433024045	R433024047	R433022386		
12.00"	R433024049	R433024051	R433022386		
14.00"	R433024053	R433024055	R433015596		
Includes Ref. Items 9a, 9c, 9d & 9e.			*Buna N rubber (Ref. 19) For high-temperature operation, consult factory		
Cylinder Lube Grease					
14 oz. tube	R431001590				

# Heavy Duty Pneumatic and Hydraulic NFPA Steel Cylinders

## POWERMASTER® PPT PNEUMATIC & PHT HYDRAULIC CYLINDERS

### POWERMASTER PHT PNEUMATIC CYLINDERS 1-1/2" — 14" BORES

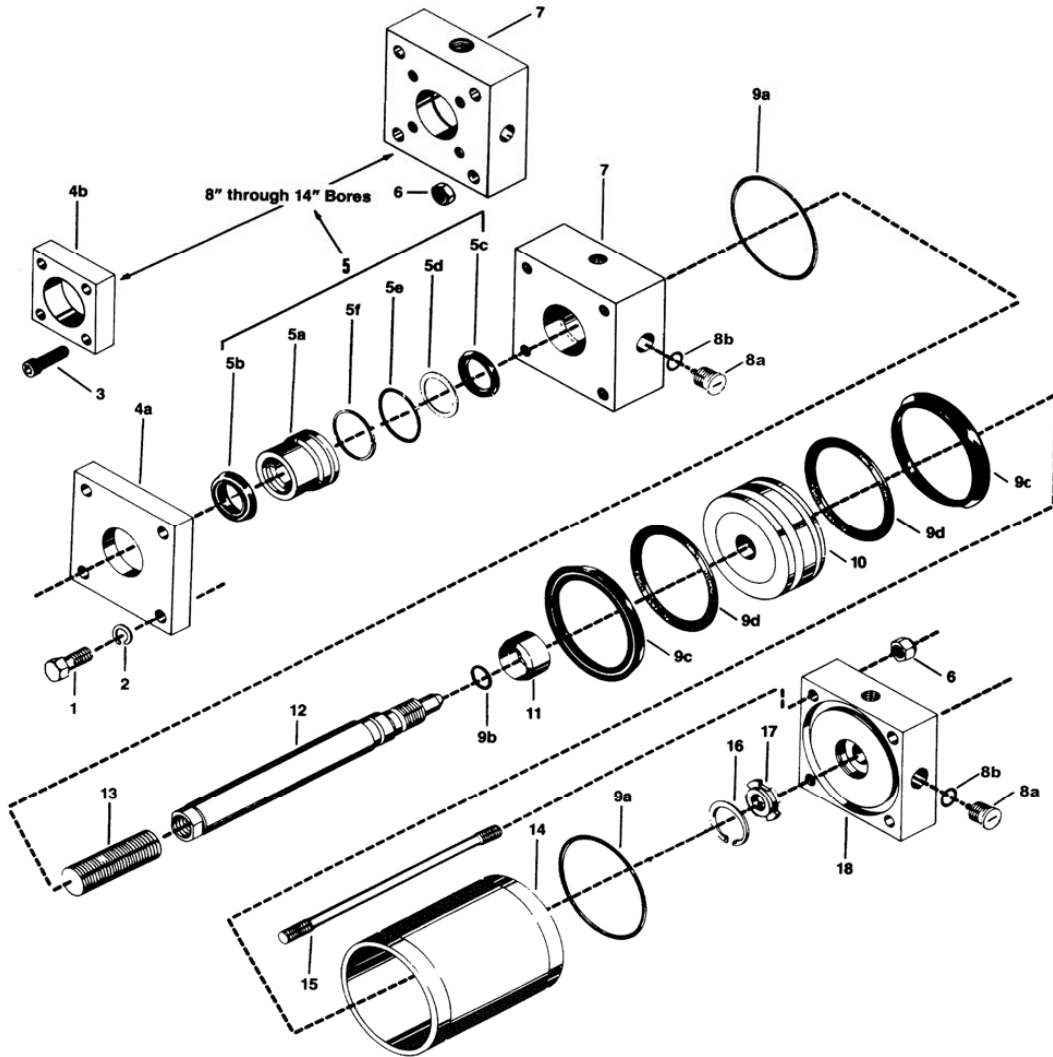

1-1/2" through 6" bores

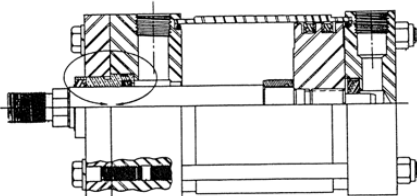

8" through 14" bores

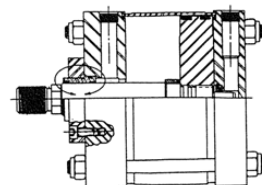

# Heavy Duty Pneumatic and Hydraulic NFPA Steel Cylinders

## POWERMASTER® PPT PNEUMATIC & PHT HYDRAULIC CYLINDERS

### POWERMASTER PHT HYDRAULIC CYLINDER 1-1/2"—14" BORES

REF.	DESCRIPTION	CUSHIONED BOTH ENDS	CUSHIONED HEAD ONLY	CUSHIONED CAP ONLY	NON-CUSHIONED
1	SCREW, Cap (1-1/2"—6" bores)	4	4	4	4
2	WASHER, Lock (1-1/2"—6" bores)	4	4	4	4
3	SCREW, Socket Head Cap (8"—14" bores)	4	4	4	4
4a	PLATE, Retainer (1-1/2"—6" bores)	1	1	1	1
4b	PLATE, Retainer (8"—14" bores)	1	1	1	1
5*	CARTRIDGE, Rod Kit	1	1	1	1
5a	BEARING, Rod	1	1	1	1
5b	WIPE, Rod	1	1	1	1
5c	PACKING, "U" Cup/O-Ring	1	1	1	1
5d	RING, Backup	1	1	1	1
5e	O-RING, Rod Bearing	1	1	1	1
5f	RING, Backup	1	1	1	1
6	NUT, Tie Rod Lock	†	†	†	†
7	HEAD	1	1	1	1
8*	CUSHION, Needle Valve Kit	2	1	1	-
8a	VALVE, Exact-a-just™ Needle & Check (include Ref. 8)	2	1	1	-
8b	O-RING, Needle Valve	2	1	1	-
9*	PISTON & TUBE, Seal Kit	1	1	1	1
9a	O-RING, End Cover	2	2	2	2
9b	O-RING, Piston Bearing	1	1	1	1
9c	SEAL, Piston	2	2	2	2
9d	RING, Piston Seal Backup	2	2	2	2
10	PISTON	1	1	1	1
11	BUSHING, Head Cushion	1	1	-	-
12	ROD, Female Piston	1	1	1	1
13	ADAPTAR, Male Piston Rod (when required)	1	1	1	1
14	TUBE, Cylinder	1	1	1	1
15	TIE ROD	4	4	4	4
16	RING, Cap Cushion Retaining	1	-	1	-
17	SEAL, Cap Cushion	1	-	1	-
18	CAP	1	1	1	1
19	NUT, Piston Retaining (Not shown - not used after 1984)	1	1	1	1

\*Recommended spare parts to be retained in stock at all times. See "REPAIR KITS" below.

† On 8" — 14" bores, 8 are always required. On 1-1/2"—6" bores, 4 are normally required, but may sometimes replace Ref. No. 1 & 2 on some mounting styles.

### REPAIR KITS

Repair parts included in the following repair kits are available only in kit form. Kits should be ordered by kit part numbers plus cylinder part number when possible. Some kits may have an excess of parts not used in some cylinder models. Discard these parts or keep for later use. Other parts not included in repair kits must be ordered separately by reference number, description, and cylinder part number.

Rod Cartridge Kit (with Rod Bearing)		
Rod Dia.	Buna N With Urethane Rod Wiper (std.)	Viton
	Part Number	Part Number
0.63"	R433022023	R433041184
1.00"	R433022025	R433033115
1.38"	R433022027	R433033112
1.75"	R433022029	R433041191
2.00"	R433022031	R433041203
2.50"	R433022033	R433023964
3.00"	R433022035	R433033105
3.50"	R433014561	
4.00"	R433014690	R433024263
4.50"		R433040358
5.00"	R433074774	
5.50"		

Includes Ref. items: 5a, 5b, 5c, 5d, 5e & 5f

Rod Seal Kit (less Rod Bearing)	
Buna N With Urethane Rod Wiper (std.)	Viton
Part Number	Part Number
R433023933	R433041186
R433023939	R433033116
R433023943	R433033111
R433023949	R433041189
R433023955	R433041201
R433023961	R433023963
R433023967	R433033107
R433014992	R433041233
R433074792	R433024265
R433074806	R433040356
R433074804	
R433074803	R433024269

Includes Ref. items 5b, 5c, 5d, 5e & 5f

Bore Size	Piston & Tube Seal Kit		Cap Cushion Seal BUNA N* Part Number
	BUNA N Part Number	VITON Part Number	
1.50"	R433023971	R433023977	R433015116
2.00"	R433023981	R433023987	R433015116
2.50"	R433023993	R433023997	R433015116
3.25"	R433024002	R433024009	R433015114
4.00"	R433024012	R433024018	R433015114
5.00"	R433024022	R433024027	R433015114
6.00"	R433024031	R433024037	R433015115
8.00"	R433024041	R433024043	R433015115
10.00"	R433024045	R433024047	R433015120
12.00"	R433024049	R433024051	R433015120
14.00"	R433024053	R433024055	R433015121

Includes Ref. Items 9a, 9c, 9d & 9e. Ref. 17

Cushion Needle Valve Assemblies (Exact-a-just™)	
Part Number	Bore Sizes
R433015236	1.5", 2", 2.5" Buna-N
R433016568	3.25", 4", 5" Buna-N
R433023258	6" thru 14" Buna-N
R433072609	1.5", 2", 2.5" Viton
R433074773	3.25", 4", 5" Viton
R433023256	6" thru 14" Viton

Includes Ref. items 8a & 8b

Cylinder Lube Grease	
14 oz. tube	Part Number
	R431001590

# Heavy Duty Pneumatic and Hydraulic NFPA Steel Cylinders



## PRESSUREMASTER® HHT HYDRAULIC CYLINDERS

**NOMINAL 3000 PSI  
NON-SHOCK 5000 PSI**

(Exceptions to 5,000 psi rating are listed on page 55)

**1-1/2" — 14" BORE**

**MACHINE TOOL GRADE NFPA DESIGNS**

---



**POSITION FEEDBACK  
(AHT) HYDRAULIC CYLINDER  
for AVENTICS HHT Series NFPA Cylinders  
See Page 39**

Note: "LB" dimension is greater than standard PRESSUREMASTER® -  
consult factory

# Heavy Duty Pneumatic and Hydraulic NFPA Steel Cylinders

AVENTICS PRESSUREMASTER® HHT HYDRAULIC CYLINDERS

## STANDARD CYLINDER SPECIFICATIONS

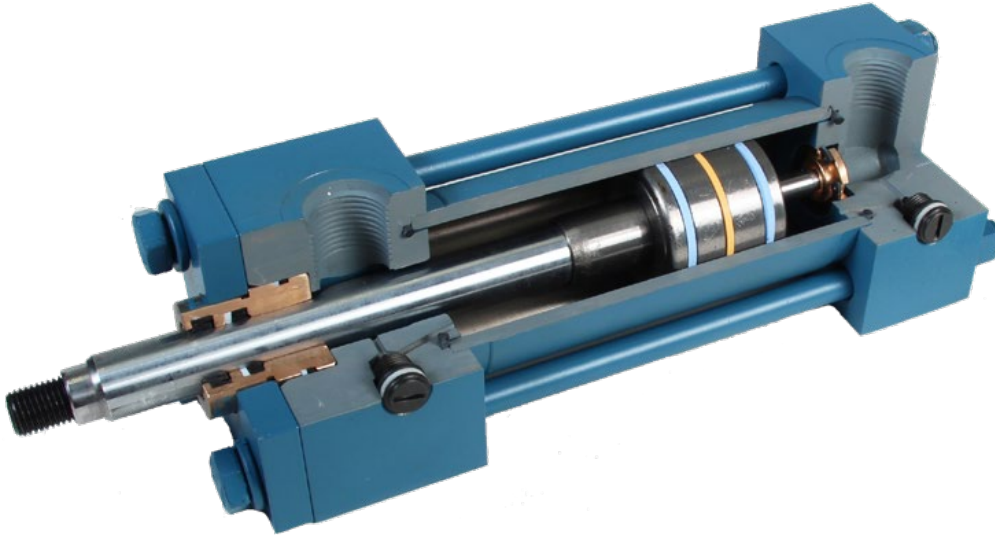

**Operating Pressures (PSI)  
by Cylinder Bore Sizes\***

Bore Size	Standard Rod	Nominal* Pressure	Non-Shock** Pressure
1-1/2	5/8		
2	1		
2-1/2	1		
3-1/4	1-3/8		
4	1-3/4		
5	2	3,000	5,000
6	2-1/2		
7	3		
8	3-1/2		
10	5		
12	5-1/2		
14	7		

\* See pressure limitations on Double Rod End cylinders on page 42 and Flange Mounted cylinder on page 44.  
\*\* Exceptions to 5,000 psi rating are listed on page 55.

§Effective March 1, 1997, SAE O-ring straight thread ports became standard

**Duty** - Nominal 3000 PSI hydraulic, non-shock 5000 PSI  
**Standards** - Meets or exceeds all J.I.C. and NFPA requirements  
**Bore Sizes** - 1-1/2" through 14" (standard), larger available  
**Piston Rods** - 5/8" through 7" (standard)

**Mounting** - 22 standard NFPA mounts

**Temperature Range** - -65°F to +200°F (-54°C to +93°C)

For Buna-N standard seals.

Optional Viton® seals for -15°F to +400°F (-26°C to +204°C) and many fluids.

**Ports**§- SAE O-Ring straight thread posts; NPTF dryseal tapered threads available. (SAE Flange ports available at extra cost.)

**Stroke** - Standard strokes furnished to nearest 1/8". Normal stroke tolerance +/-1/16". Closer stroke tolerances available, consult factory.

**Rod End Threads** - Standard KK1 male and female threads plus KK2 oversize male thread. Other rod end styles optional.

**Cushions** - Available for all bore sizes, at either or both ends.

**Piston Rods** - Case hardened to 50-55 Rockwell "C" (except 5/8") chrome-plated and finished to 15 micro-inches or better. Can be certified to meet ASTM B-117 corrosion resistance test.

**Tie Rods** - High tensile, 1144 stress proof steel

**Cylinder Tube** - Honed, steel tubing

**Double End Rod** - Available in many mounting styles to meet special needs



# Heavy Duty Pneumatic and Hydraulic NFPA Steel Cylinders

## AVENTICS PRESSUREMASTER® HHT HYDRAULIC CYLINDERS

### CYLINDER SPECIFICATIONS

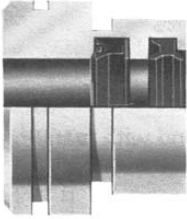

Extra-long rod bearing provides for maximum support against side-loads including external misalignment. Marine-grade 660 bronze material has superior non-scoring properties and dimensional stability. Bearing is pilot fitted into the head assuring true concentricity and long bearing and seal life. Cartridge can be quickly and easily changed without special tools.



Self-aligning U-cup/O-ring seal coordinates operating pressures with sealing forces providing a positive sealing with minimum friction. Urethane Poly-pak rod seal provides long life in an operating range of  $-65^{\circ}\text{F}$  to  $+200^{\circ}\text{F}$ . Viton seals  $-15^{\circ}\text{F}$  to  $+400^{\circ}\text{F}$  are also available for use with many special fluids. (Special fluids should be checked for compatibility with Viton)

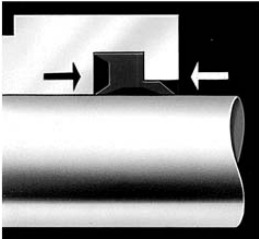

Double Duty Twin Lip rod wiper provides dirt protection for the rod bearing and rod seal. External lip prevents entry of contaminants into the bearing area on in-stroke and internal lip wipes rod on out-stroke and serves as a secondary seal.

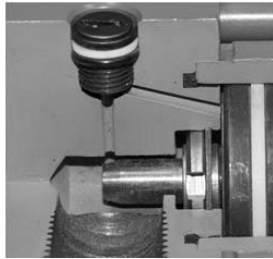

The Pressuremaster self-aligning cushion design provides a positive sealing cushion with fast piston breakaway response. Head cushion is solid with a floating cushion bushing on the rod and the cap end has a floating bronze insert.

The AVENTICS Exact-a-just™ combination needle and check valve eliminates the need for separate ball checks (thus leaving a quadrant free for other possible use.)

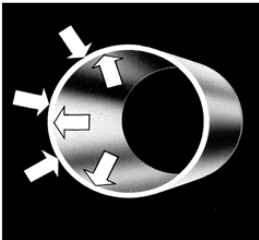

Dent resistant heavy wall steel tubing is honed to a 12 micro-inch, or better, finish, for minimum friction and long seal life.



The unique Pressuremaster piston design incorporates a center filled Teflon® seal continuously loaded by an O-ring with two Teflon® split rings as load bearings (additional bearing rings are provided above 8" bore sizes). Design provided an ideal coordination of operating pressures with proper sealing forces and result in long, trouble-free service life using petroleum or high water base fluids. Cast iron piston rings, Poly-pak and Viton seals are also available.

Teflon® is a registered trademark of the DuPont company

# Heavy Duty Pneumatic and Hydraulic NFPA Steel Cylinders

## AVENTICS PRESSUREMASTER® HHT HYDRAULIC CYLINDERS

### CYLINDER OPTIONS

#### VITON SEALS

Available for high temperature air service in a temperature range of -15°F to 400°F, and with many special hydraulic fluids. (Special fluids should be checked for compatibility with Viton).

#### PISTON ROD OPTIONS

Non-standard rod ends are available including rod and thread extensions, special threads and rod end machining, and additional wrench flats. (Catalog dimensional changes must be specified). Optional rod materials are also available for specific applications and environmental conditions: Stainless steel – 303 and 17-4 PH

#### METALLIC ROD SCRAPER

Metal scraper available for the removal of tough/hardened matter adhering to piston rod. (Rod boots for exterior rod protection might also be considered).

#### PISTON SEALS

Poly-pak piston seals are available for positive sealing in continuous holding applications. U-cup/O-ring loaded provides for tight sealing when pressure vary.

#### PORT OPTIONS

Effective 3/1/97, SAE O-Ring straight thread ports are standard. NPTF dryseal tapered threads are optional at no additional charge. Other standard size ports, oversize welded coupling ports and multiple ports are also available where design dimensions permit. SAE 4 Bolt Split Flange ports are available in the bore sizes where design space permits.

#### TUBE BLEEDS

Available for bleeding hydraulic cylinders.

#### STOP TUBE

Internal stop tube or dual position is available for reducing excessive bearing loads and jackknifing conditions in long stroke push cylinders. (See page 68 for determining stop tube length required).

#### COMBINATION MOUNTING

Additional cylinder mountings are available where design space permits.

#### WATER SERVICE

Model HW is available for water service and includes chrome-plated I.D. tube, electroless nickel plated head, cap piston, and cushion parts. Stainless steel rod is also recommended for water service.

#### EPOXY PAINT

Available for additional exterior cylinder protection in corrosive environments. Painting includes one coat of Yellow Zinc Chromate Primer and one coat of Black Epoxy Enamel.

#### TAPPED RETAINER PLATE

Head retainer plate tapped for tie rods available when bolts or tie rod nuts are not permitted on head end. (Available for 1-1/2"–6" bore sizes).

#### EXTRA CHECK VALVE (Exact-a-just™)

Available for faster breakway response for cushioned cylinders.

CONSULT FACTORY FOR OTHER OPTION REQUIREMENTS NOT SHOWN IN THIS CATALOG

# Heavy Duty Pneumatic and Hydraulic NFPA Steel Cylinders

## AVENTICS PRESSUREMASTER® HHT HYDRAULIC CYLINDERS

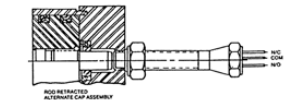
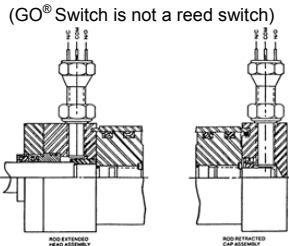
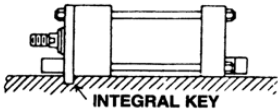
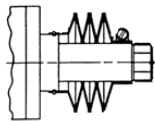
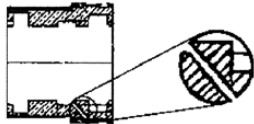
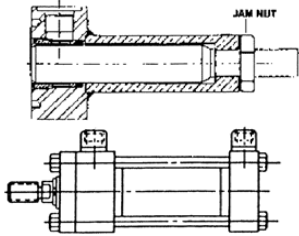

GO® Switch is standard on 7" to 14" bore sizes.

**CAUTION**  
 THESE UNITS ARE **NOT**  
 INTENDED TO BE USED AS  
 A FINAL SAFETY DEVICE

### CYLINDER OPTIONS

Emerson offers a standard arrangement to provide cylinder stroke adjustment. When an application requires a precise cylinder stroke or when infrequent stroke length adjustment is required, this retracted stroke adjustment should be specified.

Oversize welded coupling ports are available for most Pressuremaster bore sizes and mountings. (Can not be provided where cylinder design or mounting space prohibits, MF6 and MF2 flange side).

Gland drains are to be used in environments where seepage is not allowable. Threaded port allows fluid to be plumbed away from the application.

Rod boots are available for additional rod protection from environmental conditions. The oil resistant cover of neoprene-coated nylon fabric is suitable for operation in an ambient temperature range of -45°F to 220°F. Consult factory for higher temperature boot requirements.

Thrust Key Retainer is available on Pressuremaster MS2, MS4 and MS7 mountings. This eliminates the need for fitted bolts or external keys to carry the trust load.

Proximity Limit Switches are available for most styles and rod sizes of Pressuremaster cylinders. These switches are mounted in the head and cap ends to confirm the extended or retracted position of the piston. The switches are actuated by the cushion bushing on the head end and the cushion spear on the cap end. No linkage or external actuator is required. Switches can be assembled in the cylinder head, cap, or rear cap face for simple and accurate piston confirmation. The switches are not sensitive to vibration and are suitable for most environments. Switch height is less than 4 inches; for critical dimensions, contact factory. Note: "Low Profile" switch is standard on 1.5" and 6" bore sizes.

### SENSING DISTANCE

End sensing of .090" (2.25mm) to .110" (2.76mm) when using a ferrous actuator approximately equal the area of the end. The differential (hysteresis) is approximately 1/2 of the sensing range. We supply most name brand switches, such as Balluff Strokemaster, P&F Low Profile, Stoke to GO® Low Profile, NAMCO and others.

### CONTACT RATING

2 AMP at 240 VAC (CSA and UL approved)  
 50 mA at 24 VDC (CSA only)

### CONTACT ARRANGEMENT

Available in Single Pole, Double Throw.

### TEMPERATURE RANGE

Tested to -22°F to +250°F. Impervious to

most environments.

Recognized by UL at 104°F (40°C) maximum

GO® is a trademark of General Equipment Manufacturing Company, Inc.

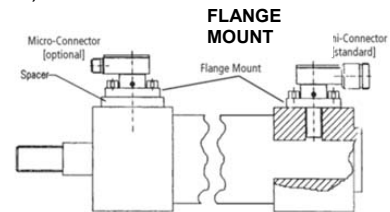

# Heavy Duty Pneumatic and Hydraulic NFPA Steel Cylinders

## AVENTICS PRESSUREMASTER® HHT HYDRAULIC CYLINDERS

### CYLINDER OPTIONS

OVERSIZE PORTS OFFERED IN WELDED BOSSES

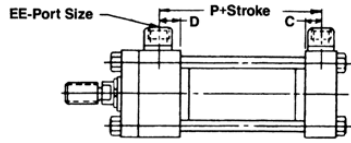
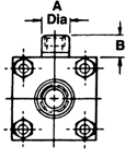

SEE CAUTION ON PAGE 38

BORE SIZE	PORT SIZE			BOSS DIA. "A"	BOSS HGT "B"	P
	SAE	DASH	NPTF			
1.5"	1-1/16-12	-12	3/4"	1.38"	1"	2.88
2"	1-1/16-12	-12	3/4"	1.38"	1"	2.88
2.5"	1-1/16-12	-12	3/4"	1.38"	1"	3.00
3.25"	1-5/16-12	-16	1"	1.75"	1.19"	3.50
4"	1-5/16-12	-16	1"	1.75"	1.19"	3.75
5"	1-5/16-12	-16	1"	1.75"	1.19"	4.25
6"	1-5/8-12	-20	1-1/4"	2.25"	1.31"	4.88
7"	1-7/8-12	-24	1-1/2"	2.50"	1.56"	5.38
8"	2-1/2-12	-32	2"	3.00"	1.56"	6.12

The above oversize ports cannot be furnished on cylinders with MF6 cap square flange mounts or in position No. 2 or No.4 on cylinders with MF2 cap rectangular flange mounts. Note that oversize ports do not necessarily mean increased flow capacity; consult factory

STANDARD DIMENSIONS

BORE	EE		
	SAE	DASH	NPTF
1.5	3/4-16	-8	1/2"
2	3/4-16	-8	1/2"
* 2.5	3/4-16	-8	1/2"
3.25	1-1/16-12	-12	3/4"
4	1-1/16-12	-12	3/4"
† 5	1-1/16-12	-12	3/4"
6	1-5/16-12	-16	1"
7	1-5/8-12	-20	1-1/4"
8	1-7/8-12	-24	1-1/2"
10	2-1/2-12	-32	2"
12	2-1/2-12	-32	2.5"
14	2-1/2-12	-32	3"

\*3/4-16 SAE Max. with 1-3/8 & 1-3/4 Rod Diameter  
†7/8-14SAE Max. with 3-1/2 Rod Diameter

### EXTENDED KEY PLATE

Emerson offers a standard arrangement of Thrust Key Mountings on the MS2, MS4 and MS7 PressureMaster cylinders. This option eliminates the need for fitted bolts or external keys to carry the thrust load. The normal headplate is extended below the head surface of the cylinder and is fitted in a keyway milled into the mounting surface of the machine member. See drawings for details.

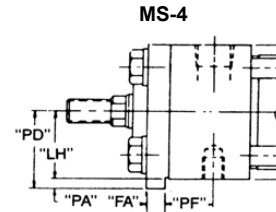
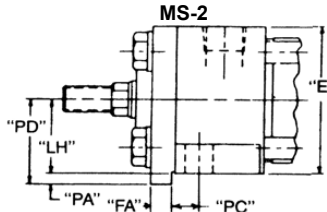
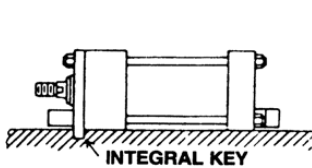

BORE	"E"	"FA"	"LH"	"PA"	"PC"	"PD"	"PF"	"PG"
1.50"	2.50	.312 +.000 -.002	1.244 +.000 -.002	.19	.44	1.44	1.06	1.19
2.00"	3.00	.562 +.000 -.002	1.494 +.000 -.002	.31	.56	1.81	1.06	1.50
2.50"	3.50	.562 +.000 -.002	1.744 +.000 -.002	.31	.75	2.06	1.06	1.50
3.25"	4.50	.687 +.000 -.003	2.244 +.000 -.002	.38	.75	2.62	1.19	1.84
4.00"	5.00	.812 +.000 -.003	2.494 +.000 -.002	.44	.94	2.94	1.19	1.94
5.00"	6.50	.812 +.000 -.003	3.244 +.000 -.002	.44	.94	3.69	1.19	2.31
6.00"	7.50	.937 +.000 -.003	3.744 +.000 -.002	.50	1.19	4.25	1.31	2.62

NOTES:

1. Use mounting bolts .06 smaller in diameter than hole size.
2. Fitted bolts or dowel pins are not needed with the trust key headplate.
3. All dimensions not shown are NFPA standard.
4. PD, PA, FA dimensions typical for all mounts.

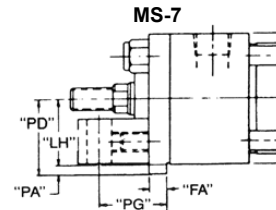

# Heavy Duty Pneumatic and Hydraulic NFPA Steel Cylinders

## AVENTICS PRESSUREMASTER® HHT HYDRAULIC CYLINDERS

### CYLINDER OPTIONS

#### ROD PROTECTIVE COVER

Emerson offers a standard rod protective cover option on PowerMaster cylinders. This option provides a dirt and oil resistant cover to extend piston rod and seal service life in applications where severe environmental conditions exist. The standard cover material is neoprene coated nylon fabric and is suitable for operation in ambient temperatures between -45°F and +220°F. Rod covers are also available for larger rod sizes on special request.

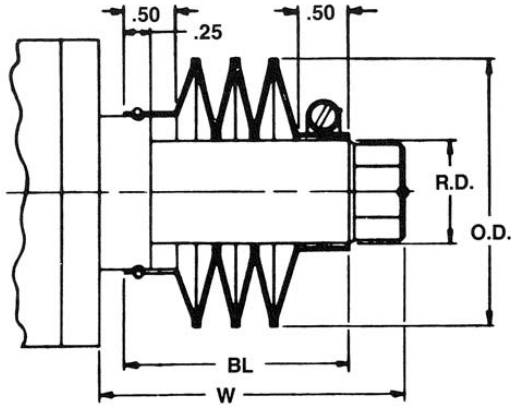

PISTON ROD		COVER O.D.	LENGTH FACTOR LF
CODE	DIAMETER		
D	.63"	2.25	.13
F	1.00"	2.62	.13
G	1.38"	3.00	.13
H	1.75"	3.38	.13
J	2.00"	3.75	.13
K	2.50"	4.38	.13
L	3.00"	5.12	.10

Determine the extra piston rod extension (ERE) required to accommodate the rod cover.

ERE = (cylinder stroke x length factor LF) + .75". See table above for LF.

Adjust cylinder catalog dimension V, WF, etc. as required to insure correct installation dimensions.

BL = ERE + .25

W = ERE + W (from dimension charts)

NOTE: These calculations are needed for cylinder application, but not for pricing.

**CAUTION:**  
**OVERSIZE PORTS**  
 Full flow diameters of oversize ports may not be obtainable with standard cylinder geometry. Consult factory.



# Heavy Duty Pneumatic and Hydraulic NFPA Steel Cylinders

## INTEGRAL POSITION FEEDBACK—ANALOG OR DIGITAL

Transducer Ready or Transducer Installed

Positioning Accuracy to .001"

Use with Proportional Hydraulic Valves

**Optional valve mounting footprints** - DO3, DO5, DO7 or DO10

**Strokes** - up to 90" (for larger strokes consult the factory)

**Pressures** - up to 3000 psi  
(available with or without valve mounting.)

**Optional transducer**- when installed, external transducer is standard, embedded is optional (contact factory)

**Bore Sizes** - 2" and larger

**Rod Diameter** - 1 3/8" and up

### Digital Position Feedback-

24 or 25 bits (binary or gray code) TTL single ended - leading edge.



### INFORMATION REQUIRED FOR A QUOTATION:

<i>Bore</i>	<i>Cylinder Mounting</i>	<i>Digital or Analog</i>
<i>Stroke</i>	<i>Valve Footprint</i>	<i>Input Voltage</i>
<i>Rod Diameter</i>	<i>Type of Cylinder</i>	<i>Output Signal</i>

### TRANSDUCER SPECIFICATIONS

Balluff linear transducer standard, others available upon request

Electrical interface	Analog	Analog	Digital
Electrical type	Voltage	Current	Start/Stop PWM
Output	0...+10V,-5...+5V,-10...+10V	4...20 mA, 0...20 mA	Start/Stop or Pulse-width-Modulated (RS422/RS485)
Output load	>2KΩ (5 mA max)	<500Ω	Per spec
Resolution	≤0.33 mV	≤0.66 μA	Controller dependent
Non-linearity	±100μm to 500mm stroke ±0.02% over 500mm stroke	±100μm to 500mm stroke ±0.02% over 500mm stroke	±100μm to 500mm stroke ±0.02% over 500mm stroke
Repeatability	Resolution / min 2μm	Resolution / min 2μm	Resolution / min 2μm
Hysteresis	≤5μm	≤5μm	≤5μm
Sampling rate	2KHz	2KHz	500 Hz stroke >2000mm 1KHz stroke <2000mm
Temperature coefficient*	[150μV/°C+ (5ppm/°C*P*V/NL)]* ΔT	[0.6μA/°C+ (10ppm/°C*P*V/NL)]* ΔT	(6μm + 5ppm*NL)/°C
Operating voltage	24 Vdc ±20%, 10...30 Vdc Or 15 Vdc ±2%	24 Vdc ±20%, 10...30 Vdc Or 15 Vdc ±2%	24 Vdc ±20%, 10...30 Vdc Or 15 Vdc ±2%
Operating current	<150 mA Nominal, @ 24 Vdc	<150mA Nominal, @ 24 Vdc	<100mA (at 1K Hz sampling rate)

Notes: Analog voltage output versions incorporate both rising and falling outputs. Analog current version must be ordered as rising or falling outputs.

\*Temperature coefficient variables:

V= output range in V

P=magnet position

NL=stroke length

I= output range in [mA]

ΔT=temperature change

# Heavy Duty Pneumatic and Hydraulic NFPA Steel Cylinders

## AVENTICS PRESSUREMASTER® HHT HYDRAULIC CYLINDERS

### MOUNTING INDEX

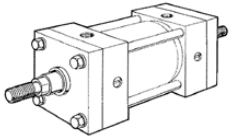
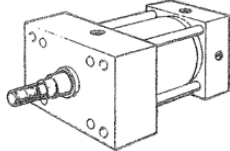
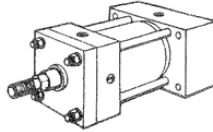
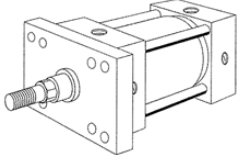
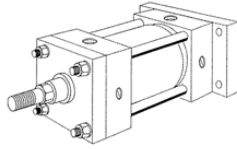
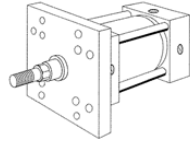
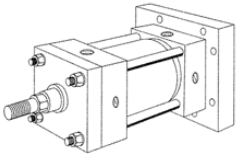
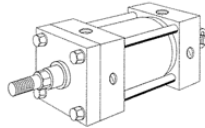
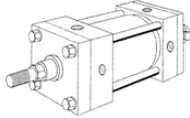
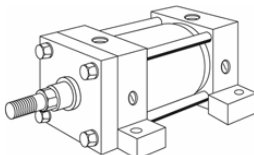
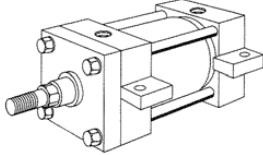
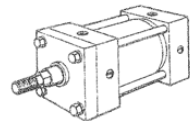
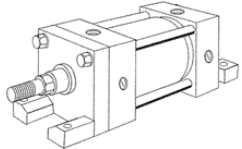
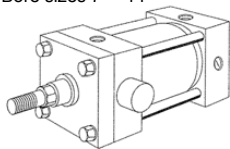
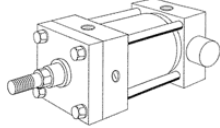
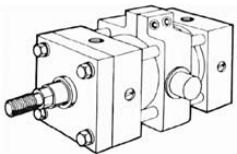
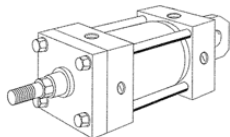
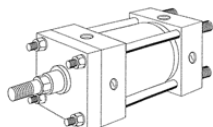
<p><b>D</b> DOUBLE ROD CYLINDER Bore sizes 1-1/2"–6"..... page 41</p> 	<p><b>ME5</b> HEAD RECTANGULAR Bore sizes 1-1/2"–6" ..... page 41 Bore sizes 7"–14"</p> 	<p><b>ME6</b> CAP RECTANGULAR Bore sizes 1-1/2"–6" ..... page 41 Bore sizes 7"–14"</p> 
<p><b>MF1</b> HEAD RECTANGULAR FLANGE Bore sizes 1-1/2"–6" ..... page 43</p> 	<p><b>MF2</b> CAP RECTANGULAR FLANGE Bore sizes 1-1/2"–6" ..... page 43</p> 	<p><b>MF5</b> HEAD SQUARE FLANGE Bore sizes 1-1/2"–6" ..... page 43 Bore sizes 7"–14"</p> 
<p><b>MF6</b> CAP SQUARE FLANGE Bore sizes 1-1/2"–6" ..... page 43 Bore sizes 7"–14"</p> 	<p><b>MP1</b> FIXED CLEVIS Bore sizes 1-1/2"–14" ..... page 45</p> <p><b>MP3</b> FIXED EYE Bore sizes 1-1/2"–14" ..... page 45</p> 	<p><b>MP2</b> DETACHABLE CLEVIS Bore sizes 1-1/2"–6" ..... page 45</p> <p><b>MP4</b> DETACHABLE EYE Bore sizes 1-1/2"–6" ..... page 45</p> 
<p><b>MS2</b> SIDE LUGS Bore sizes 1-1/2"–6" ..... page 47 Bore sizes 7"–14"</p> 	<p><b>MS3</b> CENTERLINE LUGS Bore sizes 1-1/2"–6" ..... page 47</p> 	<p><b>MS4</b> SIDE TAPPED Bore sizes 1-1/2"–6" ..... page 47</p> <p><b>MX0</b> NO MOUNTINGS Bore sizes 1-1/2"–14" ..... page 47</p> 
<p><b>MS7</b> SIDE END LUGS Bore sizes 1-1/2"–6" ..... page 47</p> 	<p><b>MT1</b> HEAD TRUNNION Bore sizes 1-1/2"–6" ..... page 49 Bore sizes 7"–14"</p> 	<p><b>MT2</b> CAP TRUNNION Bore sizes 1-1/2"–6" ..... page 49 Bore sizes 7"–14"</p> 
<p><b>MT4</b> INTERMEDIATE FIXED TRUNNION Bore sizes 1-1/2"–6" ..... page 49 Bore sizes 7"- 14"</p> 	<p><b>MU3</b> UNIVERSAL CLEVIS Bore sizes 1-1/2"–6" ..... page 51</p> 	<p><b>MX1</b> TIE ROD EXTENDED Bore sizes 1-1/2"–6" ..... page 53</p> <p><b>MX2</b></p> <p><b>MX3</b></p> <p><b>MX4</b></p> 

# Heavy Duty Pneumatic and Hydraulic NFPA Steel Cylinders

## AVENTICS PRESSUREMASTER® HHT HYDRAULIC CYLINDERS

### RECTANGULAR HEAD AND CAP FLANGE MOUNT DOUBLE ROD END

#### ME5 HEAD RECTANGULAR

Bore Sizes 1-1/2"–6"  
Bore Sizes 7"–14"

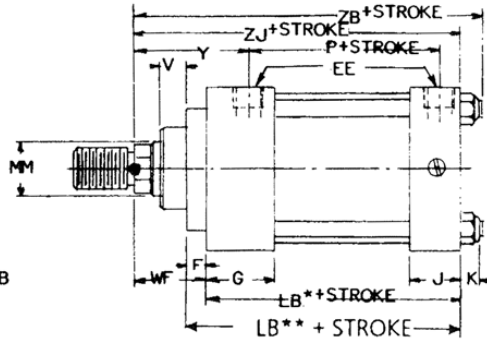
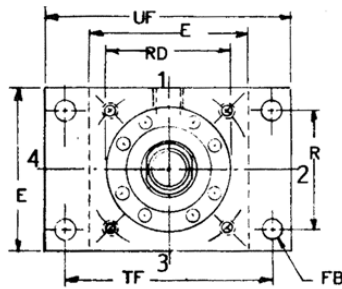
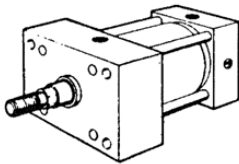

#### RD TOLERANCES:

(1-1/2–6")

+ .000

- .004

(7–14")

± .015

\*7"–14" Bores only

\*\*1-1/2–6" Bores only

CUSHION NEEDLE-CHECK VALVE ONLY ON

#### ME6 CAP RECTANGULAR

Bore Sizes 1-1/2"–6"  
Bore Sizes 7"–14"

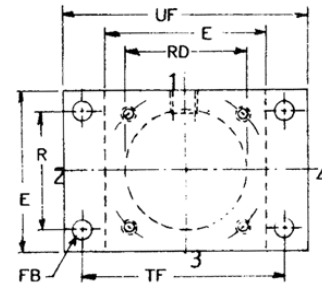
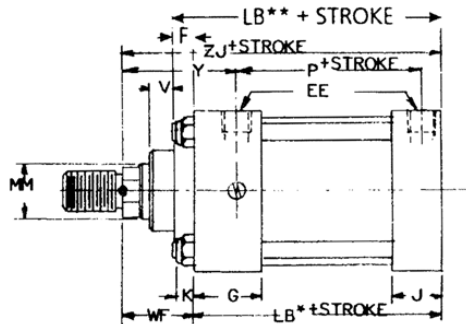
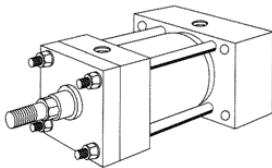

#### RD TOLERANCES:

(1-1/2–6")

+ .000

- .004

(7–14")

± .015

\*7"–14" Bores only

\*\*1-1/2–6" Bores only

CUSHION NEEDLE-CHECK VALVE ONLY ON  
SIDE 1 OR 3 FOR FLANGE END

#### D DOUBLE ROD CYLINDER

Bore Sizes 1-1/2"–6"

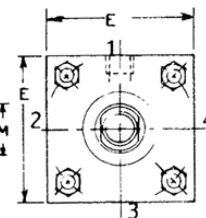
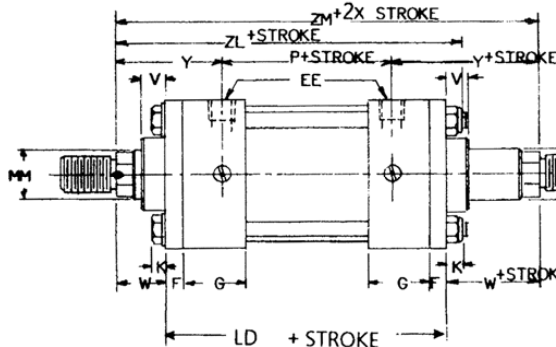
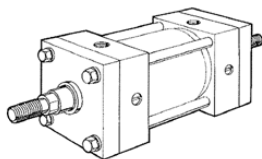

# Heavy Duty Pneumatic and Hydraulic NFPA Steel Cylinders

## AVENTICS PRESSUREMASTER® HHT HYDRAULIC CYLINDERS

### HEAD FLANGE MOUNT CAP FLANGE MOUNT DOUBLE ROD CYLINDERS

Solid Head and Cap Flange Mounts are some of the strongest, most rigid methods of mounting cylinders. The Head Flange type mounting is best in a tension application. The Cap Flange type mounting is best in a thrust application.

Double Rod End Cylinders are available in every mounting style except clevis or pin type. For dimensions on specific mounting styles, consult the page showing the required mounting. On cylinders where the rod ends are not the same, be sure to specify where each rod end is located in relation to the mounting requirements. Note that bore sizes 1-1/2"–6" have square retainers, the same square size as the head on both ends. One of these retainers is held in place by the tie rod nuts, and therefore cannot be removed without loosening the tie rods.

TABLE 1 - Dimensions affected by rod diameter.

Bore Size	MM Rod	V	Y	RD*	WF	ZB	ZJ	ZL	ZM
1.50"	0.625	0.25	2.00	2.500	1.00	6.06	5.63	6.69	6.88
	1.000	0.50	2.38	2.500	1.38	6.43	6.00	7.06	7.63
2.00"	1.000	0.25	2.38	3.000	1.38	6.57	6.00	7.45	7.63
	1.375	0.38	2.63	3.000	1.63	6.82	6.25	7.70	8.13
2.50"	1.000	0.25	2.38	3.500	1.38	6.70	6.13	7.57	7.75
	1.375	0.38	2.63	3.500	1.63	6.95	6.38	7.82	8.25
3.25"	1.750	0.50	2.88	4.000	1.88	7.20	6.63	8.07	8.75
	1.375	0.25	2.75	4.000	1.63	7.85	7.13	8.85	9.00
4.00"	1.750	0.38	3.00	4.000	1.88	8.10	7.38	9.10	9.50
	2.000	0.38	3.13	4.000	2.00	8.22	7.50	9.22	9.75
5.00"	1.750	0.25	3.00	4.500	1.88	8.35	7.63	9.47	9.75
	2.000	0.25	3.13	4.500	2.00	8.48	7.75	9.60	10.00
6.00"	2.500	0.38	3.38	4.500	2.25	8.73	8.00	9.85	10.50
	2.000	0.25	3.13	4.000	2.00	9.26	8.25	10.38	10.50
7.00"	2.500	0.38	3.38	4.375	2.25	9.51	8.50	10.63	11.00
	3.000	0.38	3.38	5.250	2.25	9.51	8.50	10.63	11.00
8.00"	3.500	0.38	3.38	5.625	2.25	9.51	8.50	10.63	11.00
	2.500	0.25	3.50	4.375	2.25	10.77	9.63	11.77	11.88
9.00"	3.000	0.25	3.50	5.250	2.25	10.77	9.63	11.77	11.88
	3.500	0.25	3.50	5.625	2.25	10.77	9.63	11.77	11.88
10.00"	4.000	0.25	3.50	6.250	2.25	10.77	9.63	11.77	11.88
	3.000	0.25	3.81	5.750	2.25	12.03	10.75		13.00
11.00"	3.500	0.25	3.81	6.250	2.25	12.03	10.75		13.00
	4.000	0.25	3.81	6.750	2.25	12.03	10.75		13.00
12.00"	5.000	0.25	3.81	7.625	2.25	12.03	10.75		13.00
	3.500	0.25	3.94	6.250	2.25	13.16	11.75		14.00
13.00"	4.000	0.25	3.94	6.750	2.25	13.16	11.75		14.00
	4.500	0.25	3.94	7.250	2.25	13.16	11.75		14.00
14.00"	5.000	0.25	3.94	8.000	2.25	13.16	11.75		14.00
	5.500	0.25	3.94	9.000	2.25	13.16	11.75		14.00
15.00"	4.500	0.25	5.00	7.625	2.94	16.60	15.06		18.00
	5.000	0.25	5.00	7.625	2.94	16.60	15.06		18.00
16.00"	5.500	0.25	5.00	9.000	2.94	16.60	15.06		18.00
	7.000	0.25	5.00	10.500	2.94	16.60	15.06		18.00
17.00"	5.500	0.25	5.75	9.000	3.19	19.23	17.69		20.88
	7.000	0.25	5.75	10.500	3.19	19.23	17.69		20.88
18.00"	8.000	0.25	5.75	11.500	3.19	19.23	17.69		20.88
	7.000	0.25	6.06	10.500	3.44	20.60	19.06		22.50
19.00"	10.000	0.50	6.06	13.500	3.44	20.60	19.06		22.50

\*RD Toleranc- 1-1/2" - 6" bores +0.000/-0.004  
7" - 14" bores +0.015/-0.015

Pressure Ratings For Double Rod  
End Pressure Cylinders

BORE SIZE	ROD SIZE	CUSHION	CUSHION	REMARK
1.500	0.625	3,000PSI	3,000PSI	
	1.000	3,000PSI	3,000PSI	
2.000	1.000	3,000PSI	3,000PSI	
	1.375	3,000PSI	3,000PSI	
2.500	1.000	3,000PSI	3,000PSI	NON-CUSH
	1.375	3,000PSI	3,000PSI	
3.250	1.750	3,000PSI	3,000PSI	
	1.375	3,000PSI	3,000PSI	
4.000	1.750	3,000PSI	3,000PSI	
	2.000	3,000PSI	3,000PSI	
5.000	1.750	3,000PSI	3,000PSI	
	2.500	3,000PSI	3,000PSI	
6.000	2.000	3,000PSI	3,000PSI	
	2.500	3,000PSI	3,000PSI	
7.000	3.000	3,000PSI	3,000PSI	
	3.500	3,000PSI	3,000PSI	
8.000	2.500	3,000PSI	3,000PSI	
	3.000	3,000PSI	3,000PSI	
9.000	3.500	3,000PSI	3,000PSI	
	4.000	3,000PSI	3,000PSI	
10.000	3.000	1,150PSI	500PSI	
	3.500	3,000PSI	2,000PSI	
11.000	4.000	2,000PSI	1,300PSI	
	5.000	3,000PSI	3,000PSI	
12.000	3.500	1,300PSI	NONE	NON-CUSH
	4.000	3,000PSI	2,250PSI	
13.000	5.000	3,000PSI	3,000PSI	
	5.500	3,000PSI	3,000PSI	
14.000	5.000	2,500PSI	2,000PSI	
	7.000	3,000PSI	3,000PSI	
15.000	5.000	1,500PSI	700PSI	
	8.500	3,000PSI	3,000PSI	
16.000	7.000	1,700PSI	1,500PSI	

Rod end options shown on page 72

TABLE 2– Dimensions not affected by rod diameter.

BORE IN	E	F	G	J	K	P	R	EE**	FB BOLT	LD	LB	TF	UF
1.500	2.50	0.38	1.75	1.50	0.43	2.88	1.63	3/4-16	0.38	5.63	5.00	3.44	4.25
2.000	3.00	0.63	1.75	1.50	0.57	2.88	2.06	3/4-16	0.50	6.13	5.25	4.13	5.13
2.500	3.50	0.63	1.75	1.50	0.57	3.00	2.56	3/4-16	0.50	6.25	5.38	4.63	5.63
3.250	4.50	0.75	2.00	1.75	0.72	3.50	3.25	1-1/16-12	0.63	7.25	6.25	5.88	7.13
4.000	5.00	0.88	2.00	1.75	0.72	3.75	3.81	1-1/16-12	0.63	7.75	6.63	6.38	7.63
5.000	6.50	0.88	2.00	1.75	1.00	4.25	4.94	1-1/16-12	0.88	8.25	7.13	8.19	9.75
6.000	7.50	1.00	2.25	2.25	1.14	4.88	5.72	1-5/16-12	1.00	9.38	8.38	9.44	11.25
7.000	8.50	1.00	2.75	2.75	1.28	5.38	6.58	1-5/8-12	1.13		8.50	10.63	12.63
8.000	9.50	1.00	3.00	3.00	1.41	6.13	7.50	1-7/8-12	1.25		9.50	11.81	14.00
10.000	12.63	1.69	3.69	3.69	1.53	8.00	9.63	2-1/2-12	1.75		12.13	15.88	19.00
12.000	14.88	1.94	4.44	4.44	1.53	9.38	11.45	2-1/2-12	2.00		14.51	18.50	22.00
14.000	17.25	2.19	4.88	4.88	1.53	10.38	13.22	2-1/2-12	2.25		15.63	21.38	25.25

\*\*Prior to 3/1/97, NPTF standard. Effective 3/1/97 SAE O-Ring straight thread ports are standard; see page 37 for sizes.

# Heavy Duty Pneumatic and Hydraulic NFPA Steel Cylinders

## AVENTICS PRESSUREMASTER® HHT HYDRAULIC CYLINDERS

### MF1 HEAD RECTANGULAR FLANGE

Bore Sizes 1-1/2"–6"

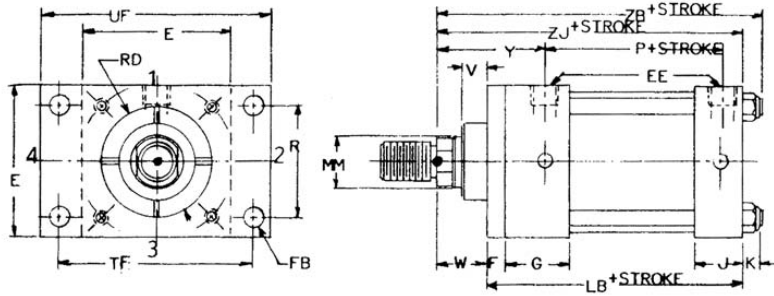
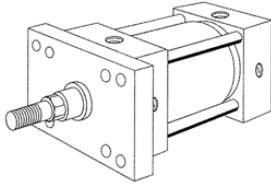

### MF2 CAP RECTANGULAR FLANGE

Bore Sizes 1-1/2"–6"

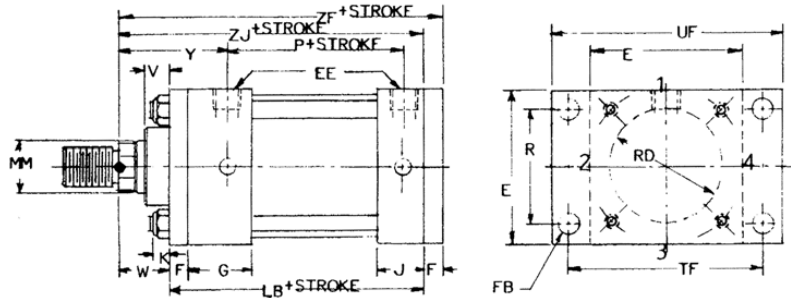
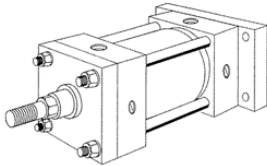

### MF5 HEAD SQUARE FLANGE

Bore Sizes 1-1/2"–6"  
Bore Sizes 7"–14"

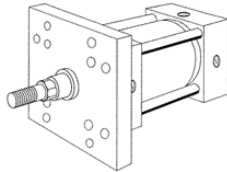

\*7"–14" Bores only  
\*\*1-1/2"–6" Bores only

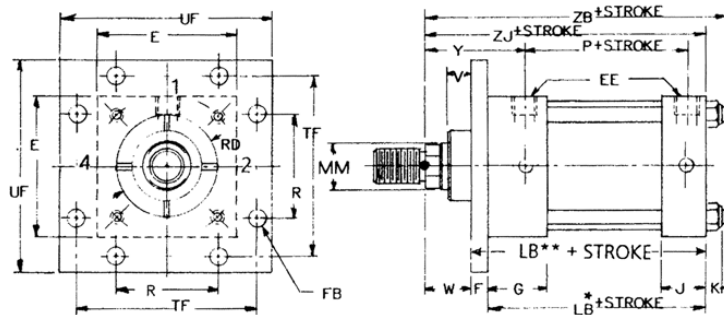

### MF6 CAP SQUARE FLANGE

Bore Sizes 1-1/2"–6"  
Bore Sizes 7"–14"

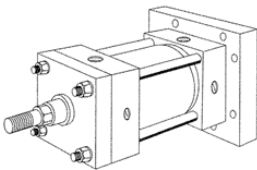

\*7"–14" Bores only  
\*\*1-1/2"–6" Bores only

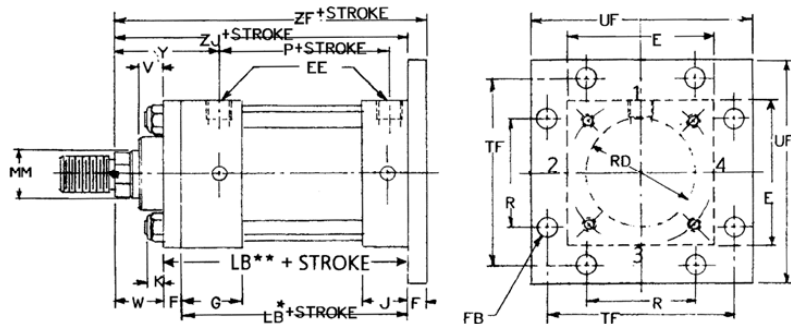



# Heavy Duty Pneumatic and Hydraulic NFPA Steel Cylinders

## AVENTICS PRESSUREMASTER® HHT HYDRAULIC CYLINDERS

### HEAD RECTANGULAR, CAP RECTANGULAR, HEAD SQUARE & CAP SQUARE FLANGE MOUNTS

TABLE 1 - Dimensions affected by rod diameter.

Bore Size	MM Rod	V	W	Y	RD	WF	ZB	ZF	ZJ
1.50"	0.625	0.25	0.63	2.00			6.06	6.00	5.63
	1.000	0.50	1.00	2.38			6.43	6.38	6.00
2.00"	1.000	0.25	0.75	2.38			6.57	6.63	6.00
	1.375	0.38	1.00	2.63			6.82	6.88	6.25
2.50"	1.000	0.25	0.75	2.38			6.70	6.75	6.13
	1.375	0.38	1.00	2.63			6.95	7.00	6.38
3.25"	1.750	0.50	1.25	2.88			7.20	7.25	6.63
	1.375	0.25	0.88	2.75			7.85	7.88	7.13
3.25"	1.750	0.38	1.13	3.00			8.10	8.13	7.38
	2.000	0.38	1.25	3.13			8.22	8.25	7.50
4.00"	1.750	0.25	1.00	3.00			8.35	8.50	7.63
	2.000	0.25	1.13	3.13			8.48	8.63	7.75
4.00"	2.500	0.38	1.38	3.38			8.73	8.88	8.00
	2.000	0.25	1.13	3.13			9.26	9.13	8.25
5.00"	2.500	0.38	1.38	3.38			9.51	9.38	8.50
	3.000	0.38	1.38	3.38			9.51	9.38	8.50
5.00"	3.500	0.38	1.38	3.38			9.51	9.38	8.50
	2.500	0.25	1.25	3.50			10.77	10.63	9.63
6.00"	3.000	0.25	1.25	3.50			10.77	10.63	9.63
	3.500	0.25	1.25	3.50			10.77	10.63	9.63
6.00"	4.000	0.25	1.25	3.50			10.77	10.63	9.63
	3.000	0.25	3.81	5.75	2.25	12.03	11.75	10.75	
7.00"	3.500	0.25	3.81	6.25	2.25	12.03	11.75	10.75	
	4.000	0.25	3.81	6.75	2.25	12.03	11.75	10.75	
7.00"	5.000	0.25	3.81	7.63	2.25	12.03	11.75	10.75	
	3.500	0.25	3.94	6.25	2.25	13.16	12.75	11.75	
8.00"	4.000	0.25	3.94	6.75	2.25	13.16	12.75	11.75	
	4.500	0.25	3.94	7.25	2.25	13.16	12.75	11.75	
8.00"	5.000	0.25	3.94	7.63	2.25	13.16	12.75	11.75	
	5.500	0.25	3.94	9.00	2.25	13.16	12.75	11.75	
10.00"	4.500	0.25	5.00	7.63	2.94	16.60	16.75	15.06	
	5.000	0.25	5.00	7.63	2.94	16.60	16.75	15.06	
10.00"	5.500	0.25	5.00	9.00	2.94	16.60	16.75	15.06	
	7.000	0.25	5.00	10.50	2.94	16.60	16.75	15.06	
12.00"	5.500	0.25	5.75	9.00	3.19	19.23	19.63	17.69	
	7.000	0.25	5.75	10.50	3.19	19.23	19.63	17.69	
12.00"	8.000	0.25	5.75	11.50	3.19	19.23	19.63	17.69	
	7.000	0.25	6.06	10.50	3.44	20.60	21.25	19.06	
14.00"	7.000	0.25	6.06	13.50	3.44	20.60	21.25	19.06	
	10.000	0.50	6.06	13.50	3.44	20.60	21.25	19.06	

Flange mounts are one of the strongest, most rigid methods of mounting. With this type of mount, there is little allowance for misalignment, so when long strokes are required, the free end opposite the mounting should be supported to prevent sagging and possible binding of the cylinder. Blind end mounts are best in a thrust load application and rod end mounts are best in tension applications. If an application exceeds the rectangular flange rating, a solid head or cap flange mount (ME5) or (ME6) is available (refer to page 41). When a less rigid mount can be used and the cylinder can be attached to a panel or bulkhead, and extended tie rod mount could be considered.

#### Pressure Limitations for Flange-mounted Cylinders

BORE SIZE	ROD DIA.	MAXIMUM OPERATING PRESSURE			
		MF1	MF2	MF5	MF6
2.50	1.00	1,500	1,500	3,000	3,000
	1.38	1,200	1,200	3,000	3,000
	1.75	1,000	1,000	3,000	3,000
3.25	1.38	1,700	1,700	3,000	3,000
	1.75	1,100	1,700	3,000	3,000
	2.00	1,000	1,700	3,000	3,000
4.00	1.75	1,900	1,900	3,000	3,000
	2.00	1,700	1,900	3,000	3,000
	2.50	1,000	1,900	3,000	3,000
5.00	2.00	1,700	1,700	3,000	3,000
	2.50	1,400	1,700	2,600	3,000
	3.00	1,100	1,700	2,200	3,000
6.00	3.50	850	1,700	1,950	3,000
	2.50	1,600	1,600	3,000	3,000
	3.00	1,300	1,600	2,550	3,000
6.00	3.50	1,150	1,600	2,250	3,000
	4.00	800	1,600	1,900	3,000
	3.00			2,300	2,300
7.00	3.50			2,000	2,300
	4.00			1,800	2,300
	5.00			1,400	2,300
8.00	3.50			2,000	2,000
	4.00			1,600	2,000
	5.00			1,400	2,000
10.00	5.50			1,200	2,000
	5.00			3,000	3,000
	7.00			3,000	3,000
12.00	5.50			3,000	3,000
	8.50			3,000	3,000
14.00	7.00			3,000	3,000

Consult factory for specific applications.

TABLE 2 - Dimensions not affected by rod diameter.

BORE IN	E	EE**	F	FB BOLT	G	J	K	LB	P	R	TF	UF
1.500	2.50	3/4-16	0.38	0.38	1.75	1.50	0.43	5.00	2.88	1.63	3.44	4.25
2.000	3.00	3/4-16	0.63	0.50	1.75	1.50	0.57	5.25	2.88	2.06	4.13	5.13
2.500	3.50	3/4-16	0.63	0.50	1.75	1.50	0.57	5.38	3.00	2.56	4.63	5.63
3.250	4.50	1-1/16-12	0.75	0.63	2.00	1.75	0.72	6.25	3.50	3.25	5.88	7.13
4.000	5.00	1-1/16-12	0.88	0.63	2.00	1.75	0.72	6.63	3.75	3.81	6.38	7.63
5.000	6.50	1-1/16-12	0.88	0.88	2.00	1.75	1.00	7.13	4.25	4.94	8.19	9.75
6.000	7.50	1-5/16-12	1.00	1.00	2.25	2.25	1.14	8.38	4.88	5.72	9.44	11.25
7.000	8.50	1-5/8-12	1.00	1.13	2.75	2.75	1.28	8.50	5.38	6.58	10.63	12.63
8.000	9.50	1-7/8-12	1.00	1.25	3.00	3.00	1.41	9.50	6.13	7.50	11.81	14.00
10.00	12.63	2-1/2-12	1.69	1.75	3.69	3.69	1.53	12.13	8.00	9.63	15.88	19.00
12.00	14.88	2-1/2-12	1.94	2.00	4.44	4.44	1.53	14.51	9.38	11.45	18.50	22.00
14.00	17.25	2-1/2-12	2.19	2.25	4.88	4.88	1.53	15.63	10.38	13.22	21.38	25.25

\*\*Prior to 3/1/97, NPTF standard. Effective 3/1/97 SAE O-Ring straight thread ports are standard; see page 37 for sizes

#### NOTES:

The bearing retainer plate is the same as the "E" dimension

For the 1-1/2"—6" bore sizes and the "RD" dimension for the

7"—14" bore sizes. Removable bearing retainer is not available in the 1-1/2"—6" bore sizes. For rod end options see page 72.

# Heavy Duty Pneumatic and Hydraulic NFPA Steel Cylinders

## AVENTICS PRESSUREMASTER® HHT HYDRAULIC CYLINDERS

### CLEVIS MOUNTS

#### MP1 FIXED CLEVIS

Bore Sizes 1-1/2"–6"  
Bore Sizes 7"–14"

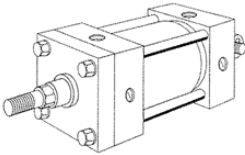

\*7"–14" Bores only  
\*\*1-1/2"–6" Bores only

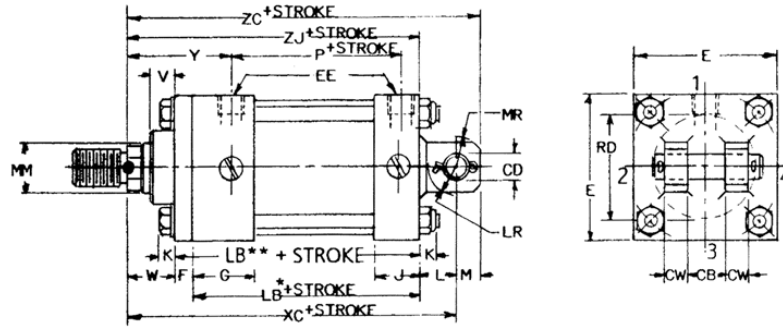

#### MP2 DETACHABLE CLEVIS

Bore Sizes 1-1/2"–6"

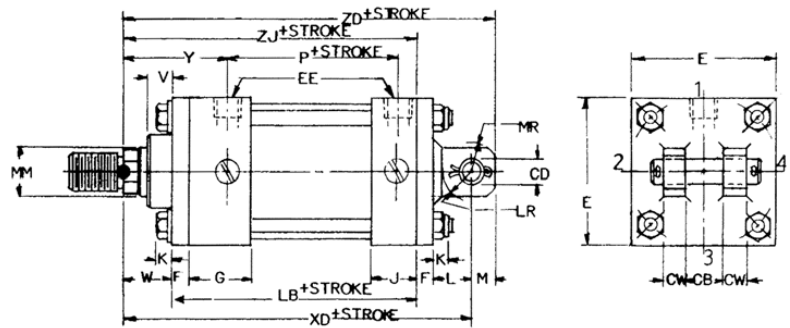
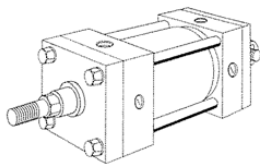

#### MP3 FIXED EYE

Bore Sizes 1-1/2"–6"  
Bore Sizes 7"–14"

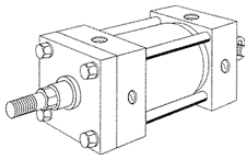

\*7"–14" Bores only  
\*\*1-1/2"–6" Bores only

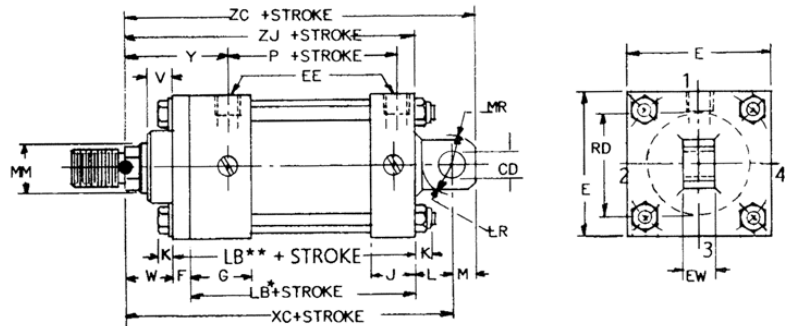

#### MP4 DETACHABLE EYE

Bore Sizes 1-1/2"–6"

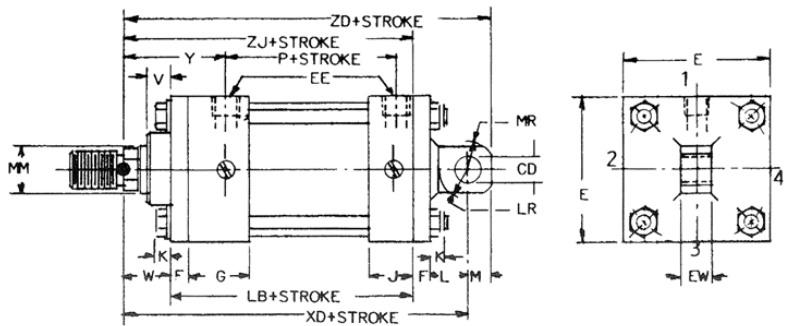
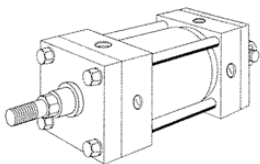

# Heavy Duty Pneumatic and Hydraulic NFPA Steel Cylinders

## AVENTICS PRESSUREMASTER® HHT HYDRAULIC CYLINDERS

### CLEVIS MOUNTS

TABLE 1 - Dimensions affected by rod diameter.

Bore Size	MM Rod	V	W	Y	RD	WF	XC	XD	ZC	ZD	ZJ
1.50"	0.625	0.25	0.63	2.00			6.38	6.75	6.88	7.25	5.63
	1.000	0.50	1.00	2.38			6.75	7.13	7.25	7.63	6.00
2.00"	1.000	0.25	0.75	2.38			7.25	7.88	8.00	8.63	6.00
	1.375	0.38	1.00	2.63			7.50	8.13	8.25	8.88	6.25
2.50"	1.000	0.25	0.75	2.38			7.38	8.00	8.13	8.75	6.13
	1.375	0.38	1.00	2.63			7.63	8.25	8.38	9.00	6.38
3.25"	1.750	0.50	1.25	2.88			7.88	8.50	8.63	9.25	6.63
	1.375	0.25	0.88	2.75			8.63	9.38	9.63	10.38	7.13
4.00"	1.750	0.38	1.13	3.00			8.88	9.63	9.88	10.63	7.38
	2.000	0.38	1.25	3.13			9.00	9.75	10.00	10.75	7.50
5.00"	1.750	0.25	1.00	3.00			9.75	10.63	11.13	12.00	7.63
	2.000	0.25	1.13	3.13			9.88	10.75	11.25	12.13	7.75
6.00"	2.500	0.38	1.38	3.38			10.13	11.00	11.50	12.38	8.00
	2.000	0.25	1.13	3.13			10.50	11.38	12.25	13.13	8.25
7.00"	2.500	0.38	1.38	3.38			10.75	11.63	12.50	13.38	8.50
	3.000	0.38	1.38	3.38			10.75	11.63	12.50	13.38	8.50
8.00"	3.500	0.38	1.38	3.38			10.75	11.63	12.50	13.38	8.50
	2.500	0.25	1.25	3.50			12.13	13.13	14.13	15.13	9.63
9.00"	3.000	0.25	1.25	3.50			12.13	13.13	14.13	15.13	9.63
	3.500	0.25	1.25	3.50			12.13	13.13	14.13	15.13	9.63
10.00"	4.000	0.25	1.25	3.50			12.13	13.13	14.13	15.13	9.63
	3.000	0.25	1.25	3.81	5.75	2.25	13.75		16.25		10.75
11.00"	3.500	0.25	1.25	3.81	6.25	2.25	13.75		16.25		10.75
	4.000	0.25	1.25	3.81	6.75	2.25	13.75		16.25		10.75
12.00"	5.000	0.25	1.25	3.81	7.63	2.25	13.75		16.25		10.75
	3.500	0.25	1.25	3.94	6.25	2.25	15.00		17.75		11.75
13.00"	4.000	0.25	1.25	3.94	6.75	2.25	15.00		17.75		11.75
	4.500	0.25	1.25	3.94	7.25	2.25	15.00		17.75		11.75
14.00"	5.000	0.25	1.25	3.94	7.63	2.25	15.00		17.75		11.75
	5.500	0.25	1.25	3.94	9.00	2.25	15.00		17.75		11.75
15.00"	4.500	0.25	1.25	5.00	7.63	2.94	19.06		22.56		15.06
	5.000	0.25	1.25	5.00	7.63	2.94	19.06		22.56		15.06
16.00"	5.500	0.25	1.25	5.00	9.00	2.94	22.19		22.56		15.06
	7.000	0.25	1.25	5.00	10.50	2.94	19.06		22.56		15.06
17.00"	5.500	0.25	1.25	5.75	9.00	3.19	22.19		26.19		17.69
	7.000	0.25	1.25	5.75	10.50	3.19	22.19		26.19		17.69
18.00"	8.500	0.50	1.25	5.75	11.50	3.19	22.19		26.19		17.69
	7.000	0.25	1.25	6.06	10.50	3.44	24.81		29.81		19.06
19.00"	10.000	0.50	1.25	6.06	13.50	3.44	24.81		29.81		19.06

The Clevis or Pin mounted cylinder is probably the most widely used of all mounts. For short strokes, medium or small cylinder applications, the clevis mounts are recommended. If this mount is applied where stroke requirements cause the overall length to be excessive, the Cap Trunnion mount can be used. Pivot mounts must always be used with a pivot type rod end attachment.

**NOTES:**

- The bearing retainer plate is the same as the "E" dimension for 1-1/2" -- 6" bore sizes and the "RD" dimension for the 7" -- 14" bore sizes.
- Rod options shown on page 72.
- MP1 and MP2 mounts include pivot pin.

TABLE 2 - Dimensions not affected by rod diameter.

BORE IN	CB	CD	CW	E	EE**	EW	F	G	J	K	L	LB	LR	M	MR	P
1.500	0.75	0.500	0.50	2.50	3/4-16	0.75	0.38	1.75	1.50	0.43	0.75	5.00	0.59	0.50	0.69	2.88
2.000	1.25	0.750	0.63	3.00	3/4-16	1.25	0.63	1.75	1.50	0.57	1.25	5.25	0.88	0.75	0.94	2.88
2.500	1.25	0.750	0.63	3.50	3/4-16	1.25	0.63	1.75	1.50	0.57	1.25	5.38	0.88	0.75	0.94	3.00
3.250	1.50	1.000	0.75	4.50	1-1/16-12	1.50	0.75	2.00	1.75	0.72	1.50	6.25	1.13	1.00	1.25	3.50
4.000	2.00	1.375	1.00	5.00	1-1/16-12	2.00	0.88	2.00	1.75	0.72	2.13	6.63	1.75	1.38	1.63	3.75
5.000	2.50	1.750	1.25	6.50	1-1/16-12	2.50	0.88	2.00	1.75	1.00	2.25	7.13	1.88	1.75	2.00	4.25
6.000	2.50	2.000	1.25	7.50	1-5/16-12	2.50	1.00	2.25	2.25	1.14	2.50	8.38	2.13	2.00	2.38	4.88
7.000	3.00	2.500	1.50	8.50	1-5/8-12	3.00	1.00	2.75	2.75	1.28	3.00	8.50	2.38	2.50	2.88	5.38
8.000	3.00	3.000	1.50	9.50	1-7/8-12	3.00	1.00	3.00	3.00	1.41	3.25	9.50	2.63	2.75	3.13	6.13
10.000	4.00	3.500	2.00	12.63	2-1/2-12	4.00	1.69	3.69	3.69	1.53	4.00	12.13	3.25	3.50	4.25	8.00
12.000	4.50	4.000	2.25	14.88	2-1/2-12	4.50	1.94	4.44	4.44	1.53	4.50	14.51	3.75	4.00	4.38	9.38
14.000	6.00	5.000	3.00	17.25	2-1/2-12	6.00	2.19	4.88	4.88	1.53	5.75	15.63	4.75	5.00	5.38	10.38

\*\*Prior to 3/1/97, NPTF standard. Effective 3/1/97 SAE O-Ring straight thread ports are standard: see page 37 for sizes.

# Heavy Duty Pneumatic and Hydraulic NFPA Steel Cylinders

## AVENTICS PRESSUREMASTER® HHT HYDRAULIC CYLINDERS

### SIDE AND LUG MOUNTS

#### MS2 SIDE LUGS

Bore Sizes 1-1/2"–6"  
Bore Sizes 7"–14"

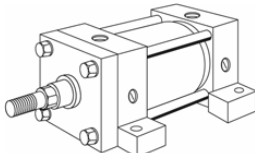

\*7"–14" Bores only  
\*\*1-1/2"–6" Bores only

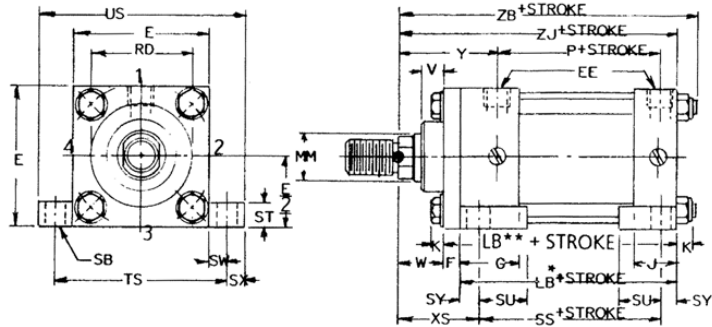

#### MS3 CENTERLINE LUGS

Bore Sizes 1-1/2"–6"

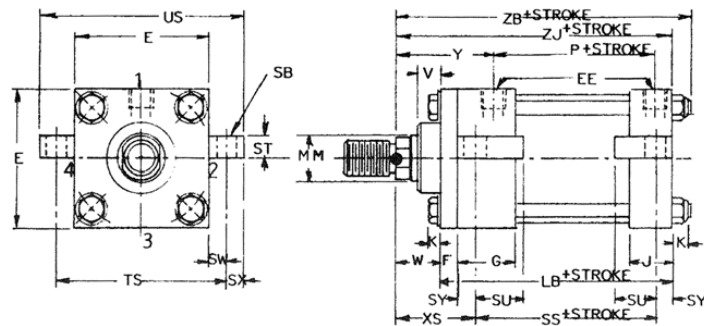
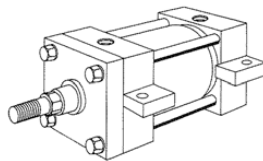

#### MS4 SIDE TAPPED

Bore Sizes 1-1/2"–6"

#### MX0 NO MOUNTING

Bore Sizes 1-1/2"–14"

Note: MX0 is MS4 less mounting holes.

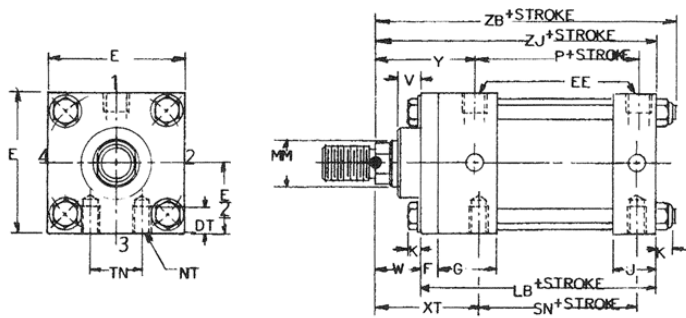
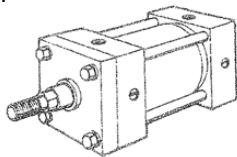

#### MS7 SIDE END LUGS

Bore Sizes 1-1/2"–6"

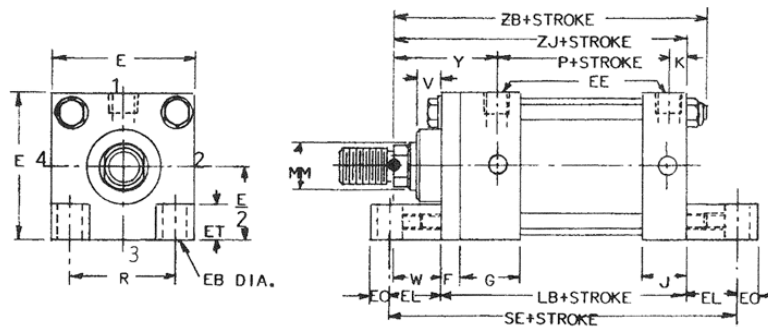
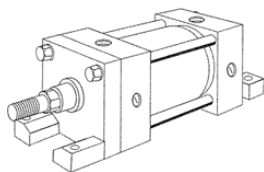

# Heavy Duty Pneumatic and Hydraulic NFPA Steel Cylinders

## AVENTICS PRESSUREMASTER® HHT HYDRAULIC CYLINDERS

### SIDE LUG, CENTERLINE LUG, SIDE TAPPED & SIDE END LUG MOUNTS

TABLE 1 - Dimensions affected by rod diameter.

Bore Size	MM Rod	V	W	Y	RD*	WF	XS	XT	ZB	ZJ
1.50"	0.625	0.25	0.63	2.00			1.38	2.00	6.06	5.63
	1.000	0.50	1.00	2.38			1.75	2.38	6.43	6.00
2.00"	1.000	0.25	0.75	2.38			1.88	2.38	6.57	6.00
	1.375	0.38	1.00	2.63			2.13	2.63	6.82	6.25
2.50"	1.000	0.25	0.75	2.38			2.06	2.38	6.70	6.15
	1.375	0.38	1.00	2.63			2.31	2.63	6.95	6.38
	1.750	0.50	1.25	2.88			2.56	2.88	7.20	6.63
3.25"	1.375	0.25	0.88	2.75			2.31	2.75	7.88	7.13
	1.750	0.38	1.13	3.00			2.56	2.88	8.10	7.38
	2.000	0.38	1.25	3.13			2.68	3.13	8.22	7.50
4.00"	1.750	0.25	1.00	3.00			2.75	3.00	8.35	7.63
	2.000	0.25	1.13	3.13			2.88	3.13	8.48	7.75
	2.500	0.38	1.38	3.38			3.13	3.38	8.73	8.00
5.00"	2.000	0.25	1.13	3.13			2.88	3.13	9.26	8.25
	2.500	0.38	1.38	3.38			3.13	3.38	9.51	8.50
	3.000	0.38	1.38	3.38			3.13	3.38	9.51	8.50
	3.500	0.38	1.38	3.38			3.13	3.38	9.51	8.50
6.00"	2.500	0.25	1.25	3.50			3.38	3.50	10.77	9.63
	3.000	0.25	1.25	3.50			3.38	3.50	10.77	9.63
	3.500	0.25	1.25	3.50			3.38	3.50	10.77	9.63
	4.000	0.25	1.25	3.50			3.38	3.50	10.77	9.63
7.00"	3.000	0.25	1.25	3.81	5.75	2.25	3.63		12.03	10.75
	3.500	0.25	1.25	3.81	6.25	2.25	3.63		12.03	10.75
	4.000	0.25	1.25	3.81	6.75	2.25	3.63		12.03	10.75
	5.000	0.25	1.25	3.81	7.63	2.25	3.63		12.03	10.75
8.00"	3.500	0.25	1.25	3.94	6.25	2.25	3.63		13.16	11.75
	4.000	0.25	1.25	3.94	6.75	2.25	3.63		13.16	11.75
	4.500	0.25	1.25	3.94	7.25	2.25	3.63		13.16	11.75
	5.000	0.25	1.25	3.94	7.63	2.25	3.63		13.16	11.75
10.00"	5.000	0.25	1.25	3.94	9.00	2.25	3.63		13.16	11.75
	4.500	0.25	1.25	5.00	7.63	2.94	4.56		16.60	15.06
	5.000	0.25	1.25	5.00	7.63	2.94	4.56		16.60	15.06
	5.500	0.25	1.25	5.00	9.00	2.94	4.56		16.60	15.06
12.00"	7.000	0.25	1.25	5.75	9.00	3.19	5.19		19.21	17.69
	8.500	0.25	1.25	5.75	10.50	3.19	5.19		19.21	17.69
	8.500	0.25	1.25	5.75	12.00	3.19	5.19		19.47	17.69
14.00"	7.000	0.25	1.25	6.06	10.50	3.44	5.94		20.59	19.06
	10.000	0.50	1.25	6.06	13.50	3.44	5.94		20.59	19.06

The side or lug mounted cylinder provides a fairly rigid mount. These type mounts can tolerate a slight amount of misalignment when the cylinder is at full stroke, but as the piston moves toward the blind end, the tolerance for misalignment decreases. It is important to note that if the cylinder is used properly, the mounting bolts are either in simple shear or tension without any compound stresses. An extended key plate option is available to eliminate the need for fitted bolts or external keys to carry the thrust load.

(See page 9)

**NOTE:**

The MS3, MS4 and MS7 mounts are only offered in 1-1/2"—6" bore sizes and have a square retainer the same size as the head. When specifying an MS2 mount with ports in the 2, 4, 6 or 8 quadrant, be sure to see that sufficient clearance between the port fitting and the lug is available to insert a bolt or cap screw into the lug.

When specifying an MS7 mount, carefully check the distance between the rod and lug to determine sufficient clearance for the rod end attachment. It may be necessary to add extra plain rod extension to move the threaded rod end out beyond the lug. The lugs serve as nuts on the bottom two tie rods therefore making it necessary to loosen the tie rods to remove the rod gland.

Rod end options shown on page 72.

TABLE 2 - Dimension not affected by rod diameter.

Bore Size	DT	E	EB Bolt	EE**	EL SQ.	EO	ET	F	G	J	K	LB	NT- THD	P	R	SB Bolt	SE §	SN	SS §	ST	SU	SW	SX	SY	TN	TS	US
1.50"	0.41	2.50	0.38	3/4-16	0.88	0.38	0.81	0.38	1.75	1.50	0.43	5.00	0.38-16	2.88	1.63	0.38	6.75	2.88	3.88	0.50	0.94	0.38	0.38	0.38	0.75	3.25	4.00
2.00"	0.50	3.00	0.50	3/4-16	0.94	0.50	0.88	0.63	1.75	1.50	0.57	5.25	0.50-13	2.88	2.06	0.50	7.13	2.88	3.63	0.75	1.25	0.50	0.50	0.50	0.94	4.00	5.00
2.50"	0.50	3.50	0.50	3/4-16	0.94	0.50	0.88	0.63	1.75	1.50	0.57	5.38	0.63-11	3.00	2.56	0.75	7.25	3.00	3.38	1.00	1.56	0.69	0.69	0.69	1.31	4.88	6.25
3.25"	0.75	4.50	0.62	1-1/16-12	1.13	0.63	1.19	0.75	2.00	1.75	0.72	6.25	0.75-10	3.50	3.25	0.75	8.50	3.50	4.12	1.00	1.56	0.69	0.69	0.69	1.50	5.88	7.25
4.00"	0.75	5.00	0.62	1-1/16-12	1.13	0.63	1.13	0.88	2.00	1.75	0.72	6.63	1.00-8	3.75	3.81	1.00	8.88	3.75	4.00	1.25	2.00	0.88	0.88	0.88	2.06	6.75	8.50
5.00"	0.75	6.50	0.88	1-1/16-12	1.50	0.75	1.47	0.88	2.00	1.75	1.00	7.13	1.00-8	4.25	4.94	1.00	10.13	4.25	4.50	1.25	2.00	0.88	0.88	0.88	2.94	8.25	10.00
6.00"	1.00	7.50	1.00	1-5/16-12	1.69	0.88	1.69	1.00	2.25	2.25	1.14	8.38	1.25-7	4.88	5.72	1.25	11.75	5.13	5.13	1.50	2.50	1.13	1.13	1.13	3.31	9.75	12.00
7.00"	8.50			1-5/8-12				1.00	2.75	2.75	1.28	8.50		5.38	6.58	1.50			5.75	1.75	2.88	1.38	1.38	1.38		11.25	14.00
8.00"	9.50			1-7/8-12				1.00	3.00	3.00	1.41	9.50		6.13	7.50	1.50			6.75	1.75	2.88	1.38	1.38	1.38		12.25	15.00
10.00"	12.63			2-1/2-12				1.69	3.69	3.69	1.53	12.13		8.00	9.63	1.50			8.88	2.25	3.50	1.63	1.63	1.63		15.88	19.13
12.00"	14.88			2-1/2-12				1.94	4.44	4.44	1.53	14.51		9.38	11.45	1.50			10.50	3.00	4.25	2.00	2.00	2.00		18.88	22.88
14.00"	17.25			2-1/2-12				2.19	4.88	4.88	1.53	15.63		10.38	13.22	1.50			10.63	4.00	5.00	2.50	2.50	2.50		22.25	27.25

\*\*Prior to 3/1/97, NPTF standard. Effective 3/1/97 SAE O-Ring straight thread ports are standard; see page 37 for sizes § for double rod cylinders 1-1/2" through 5" bores, add 0.25" to these dimensions



# Heavy Duty Pneumatic and Hydraulic NFPA Steel Cylinders

## AVENTICS PRESSUREMASTER® HHT HYDRAULIC CYLINDERS

### TRUNNION MOUNTS

#### MT1 HEAD TRUNNION

Bore Sizes 1-1/2"–6"  
Bore Sizes 7"–14"

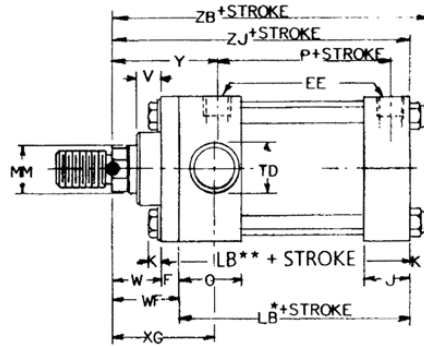
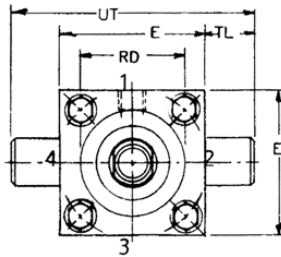
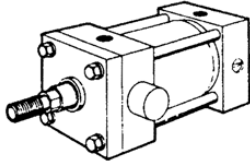

\*7"–14" Bores only  
\*\*1-1/2"–6" Bores only

#### MT2 CAP TRUNNION

Bore Sizes 1-1/2"–6"  
Bore Sizes 7"–14"

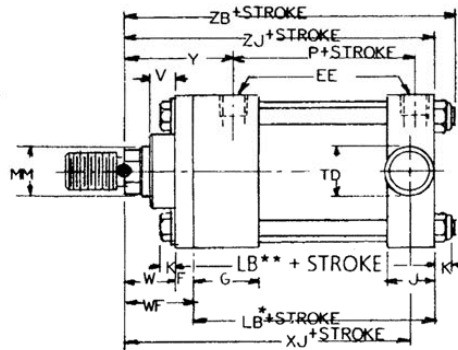
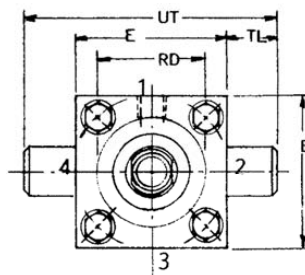
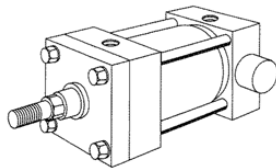

\*7"–14" Bores only  
\*\*1-1/2"–6" Bores only

#### MT4 INTERMEDIATE FIXED TRUNNION

Bore Sizes 1-1/2"–6"  
Bore Sizes 7"–14"

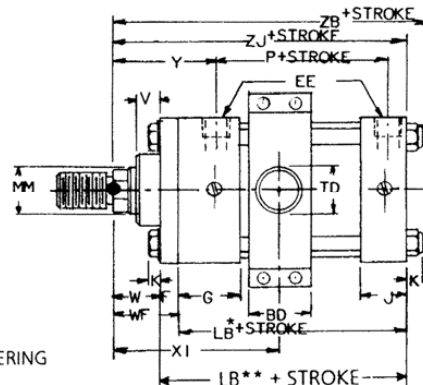
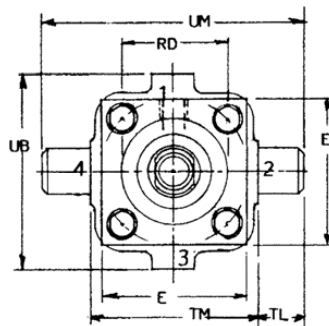
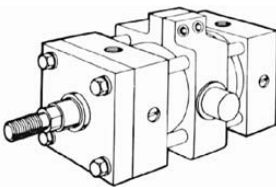

SPECIFY \*XI" DIMENSION WHEN ORDERING

\*7"–14" Bores only  
\*\*1-1/2"–6" Bores only

# Heavy Duty Pneumatic and Hydraulic NFPA Steel Cylinders

## AVENTICS PRESSUREMASTER® HHT HYDRAULIC CYLINDERS

### TRUNNION MOUNTS

TABLE 1 - Dimensions affected by rod diameter.

Bore Size	MM Rod	V	W	Y	RD*	WF	XG	XI MIN	XJ	ZB	ZJ
1.50"	0.625	0.25	0.63	2.00			2.00	3.66	4.88	6.06	5.63
	1.000	0.50	1.00	2.38			2.38	4.03	5.25	6.43	6.00
2.00"	1.000	0.25	0.75	2.38			2.38	4.03	5.25	6.57	6.00
	1.375	0.38	1.00	2.63			2.63	4.28	5.50	6.82	6.25
2.50"	1.000	0.25	0.75	2.38			2.38	4.16	5.38	6.70	6.13
	1.375	0.38	1.00	2.63			2.63	4.41	5.63	6.95	6.38
	1.750	0.50	1.25	2.88			2.88	4.66	5.88	7.20	6.63
3.25"	1.375	0.25	0.88	2.75			2.75	4.78	6.25	7.85	7.13
	1.750	0.38	1.13	3.00			3.00	5.03	6.50	8.10	7.38
	2.000	0.38	1.25	3.13			3.13	5.16	6.63	8.22	7.50
4.00"	1.750	0.25	1.00	3.00			3.00	5.16	6.75	8.35	7.63
	2.000	0.25	1.13	3.13			3.13	5.28	6.88	8.48	7.75
	2.500	0.38	1.38	3.38			3.38	5.53	7.13	8.73	8.00
5.00"	2.000	0.25	1.13	3.13			3.13	5.53	7.38	9.26	8.25
	2.500	0.38	1.38	3.38			3.38	5.72	7.63	9.51	8.50
	3.000	0.38	1.38	3.38			3.38	5.72	7.63	9.51	8.50
	3.500	0.38	1.38	3.38			3.38	5.72	7.63	9.51	8.50
6.00"	2.500	0.25	1.25	3.50			3.50	6.16	8.38	10.77	9.63
	3.000	0.25	1.25	3.50			3.50	6.16	8.38	10.77	9.63
	3.500	0.25	1.25	3.50			3.50	6.16	8.38	10.77	9.63
	4.000	0.25	1.25	3.50			3.50	6.16	8.38	10.77	9.63
7.00"	3.000	0.25		3.81	5.75	2.25	3.63	6.91	9.38	12.03	10.75
	3.500	0.25		3.81	6.25	2.25	3.63	6.91	9.38	12.03	10.75
	4.000	0.25		3.81	6.75	2.25	3.63	6.91	9.38	12.03	10.75
	5.000	0.25		3.81	7.63	2.25	3.63	6.91	9.38	12.03	10.75
8.00"	3.500	0.25		3.94	6.25	2.25	3.75	7.16	10.25	13.16	11.75
	4.000	0.25		3.94	6.75	2.25	3.75	7.16	10.25	13.16	11.75
	4.500	0.25		3.94	7.25	2.25	3.75	7.16	10.25	13.16	11.75
	5.000	0.25		3.94	7.63	2.25	3.75	7.16	10.25	13.16	11.75
	5.500	0.25		3.94	9.00	2.25	3.75	7.16	10.25	13.16	11.75
10.00"	4.500	0.25		5.00	7.63	2.94	4.75	9.13	13.25	16.60	15.06
	5.000	0.25		5.00	7.63	2.94	4.75	9.13	13.25	16.60	15.06
	5.500	0.25		5.00	9.00	2.94	4.75	9.13	13.25	16.60	15.06
	7.000	0.25		5.00	10.50	2.94	4.75	9.13	13.25	16.60	15.06
12.00"	5.500	0.25		5.75	9.00	3.19	5.38	10.75	15.50	19.23	17.69
	7.000	0.25		5.75	10.50	3.19	5.38	10.75	15.50	19.23	17.69
	8.000	0.25		5.75	11.50	3.19	5.38	10.75	15.50	19.23	17.69
14.00"	7.000	0.25		6.06	10.50	3.44	5.81	11.94	16.69	20.60	19.06
	10.000	0.50		6.06	13.50	3.44	5.81	11.94	16.69	20.60	19.06

All trunnion mount cylinders need a provision on both ends for pivoting. These types of cylinders are designed to carry shear loads and the trunnion and pivot pins should be carried by bearings that are rigidly held and closely fit for the entire length of the pin.

**CAUTION NOTE:**

Rod end trunnion mount cylinders in bore sizes 5"—8" with oversize piston rods and bores 10" - 14" with all diameters should not be used over 1500 PSI. If your application requires higher pressure, consult the factory.

**NOTES:**

Specify "XI" dimension when ordering MT4 Intermediate Fixed Trunnion mounts. If not specified, trunnion will be located at the center of the tube.

The bearing retainer plate is the same as the "E" dimension for 1-1/2"—6" bore sizes and the "RD" dimension for the 7"—14" bore sizes.

For mounting MT1 1-1/2" through 6" bores only, a design change effective October 1, 2015 resulted in some changes in the XG dimensions column, and the new dimensions are shown here. To confirm the XG dimension for cylinders manufactured prior to October 1, 2015, contact the factory.

Rod end options shown on page 72.

TABLE 2 - Dimensions not affected by rod diameter.

BORE IN	BD	E	EE**	F	G	J	K	LB	P	TD	TL	TM	UB	UM	UT
1.500	1.44	2.50	3/4-16	0.38	1.75	1.50	0.43	5.00	2.88	1.000	1.00	2.75	4.00	4.75	4.50
2.000	1.44	3.00	3/4-16	0.63	1.75	1.50	0.57	5.25	2.88	1.380	1.38	3.25	4.50	6.00	5.75
2.500	1.69	3.50	3/4-16	0.63	1.75	1.50	0.57	5.38	3.00	1.380	1.38	3.75	5.25	6.50	6.25
3.250	1.94	4.50	1-1/16-12	0.75	2.00	1.75	0.72	6.25	3.50	1.750	1.75	5.00	6.50	8.50	8.00
4.000	2.19	5.00	1-1/16-12	0.88	2.00	1.75	0.72	6.63	3.75	1.750	1.75	5.50	7.38	9.00	8.50
5.000	2.69	6.50	1-1/16-12	0.88	2.00	1.75	1.00	7.13	4.25	1.750	1.75	7.00	9.25	10.50	10.00
6.000	2.94	7.50	1-5/16-12	1.00	2.25	2.25	1.14	8.38	4.88	2.000	2.00	8.00	10.25	12.00	11.50
7.000	3.44	8.50	1-5/8-12	1.00	2.75	2.75	1.28	8.50	5.38	2.500	2.50	9.25	12.25	14.25	13.50
8.000	3.44	9.50	1-7/8-12	1.00	3.00	3.00	1.41	9.50	6.13	3.000	3.00	11.00	14.00	17.00	15.50
10.000	4.66	12.63	2-1/2-12	1.69	3.69	3.69	1.53	12.13	8.00	3.500	3.50	14.00	17.75	21.00	19.63
12.000	5.91	14.88	2-1/2-12	1.94	4.44	4.44	1.53	14.51	9.38	4.000	4.00	17.00	20.50	25.00	22.88
14.000	6.91	17.25	2-1/2-12	2.19	4.88	4.88	1.53	15.63	10.38	4.500	4.50	19.00	23.50	28.00	27.25

\*\*Prior to 3/1/97, NPTF standard. Effective 3/1/97 SAE O-Ring straight thread ports are standard: see page 37 for sizes.

# Heavy Duty Pneumatic and Hydraulic NFPA Steel Cylinders

## AVENTICS PRESSUREMASTER® HHT HYDRAULIC CYLINDERS

### UNIVERSAL CLEVIS MOUNT

#### MU3 UNIVERSAL CLEVIS Bore Sizes 1-1/2"–6"

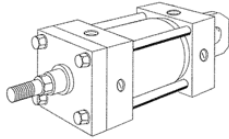

Note: Spherical rod eye shown for critical dimensions only; not included with MU3. For dimensions and ordering, see p. 74

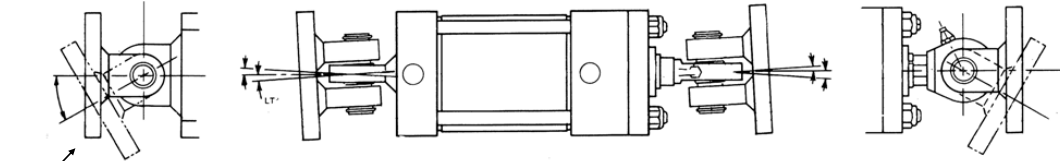
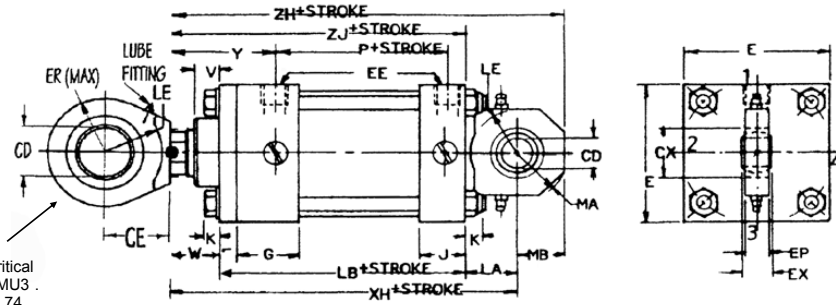

Spherical Bracket (see page 52)

Utilization of spherical bearings compensates for from 5° to 10° of misalignment in any direction.

### MULTIPLE TIE ROD CONSTRUCTION

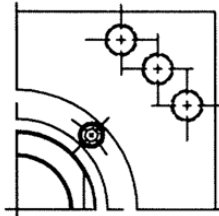

3 tie rods are added at each corner for cylinder bore sizes of 10 inches

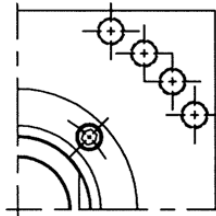

4 tie rods are added at each corner for cylinder bore sizes of 12 inches

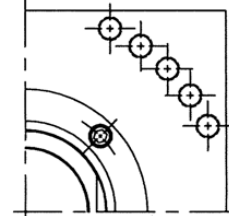

5 tie rods are added at each corner for cylinder bore sizes of 14 inches

# Heavy Duty Pneumatic and Hydraulic NFPA Steel Cylinders

## AVENTICS PRESSUREMASTER® HHT HYDRAULIC CYLINDERS

### UNIVERSAL CLEVIS MOUNT

**TABLE 1** - Dimensions affected by rod diameter.

BORE IN	MM ROD	V	W	Y	XH	ZH	ZJ
1.500	0.625	0.25	0.63	2.00	6.38	7.13	5.63
	1.000	0.50	1.00	2.38	6.75	7.50	6.00
2.000	1.000	0.25	0.75	2.38	7.25	8.34	6.00
	1.375	0.38	1.00	2.63	7.50	8.63	6.25
2.500	1.000	0.25	0.75	2.38	7.38	8.50	6.13
	1.375	0.38	1.00	2.63	7.63	8.75	6.38
	1.750	0.50	1.25	2.88	7.88	9.00	6.63
3.250	1.375	0.25	0.88	2.75	8.63	10.13	7.13
	1.750	0.38	1.13	3.00	8.88	10.38	7.38
	2.000	0.38	1.25	3.13	9.00	10.50	7.50
4.000	1.750	0.25	1.00	3.00	9.75	11.69	7.63
	2.000	0.25	1.13	3.13	9.88	11.94	7.75
	2.500	0.38	1.38	3.38	10.13	12.19	8.00
5.000	2.000	0.25	1.13	3.13	10.50	13.19	8.25
	2.500	0.38	1.38	3.38	10.75	13.44	8.50
	3.000	0.38	1.38	3.38	10.75	13.44	8.50
	3.500	0.38	1.38	3.38	10.75	13.44	8.50
6.000	2.500	0.25	1.25	3.50	12.25	15.31	9.63
	3.000	0.25	1.25	3.50	12.25	15.31	9.63
	3.500	0.25	1.25	3.50	12.25	15.31	9.63
	4.000	0.25	1.25	3.50	12.25	15.31	9.63

The MU3 (Universal) type mount is a pivot mount MP3 with a spherical bearing fitted into the pivot to permit 5 to 10 degrees of movement in a plane perpendicular to the major plant of pivot movement. It is probably the most serviceable of the pivoted centerline mounts. For maximum effectiveness, a spherical rod end fitting should be utilized at the same time.

**NOTES:**

Rod end thread options shown on page 72. For spherical rod eye, see page 74.

**TABLE 2** - Dimensions not affected by rod diameter.

BORE IN	CD*	CX	E	EE**	EX	EP	F	G	J	K	LA	LB	LE	MA	MB	P
1.500	0.500	0.875	2.50	3/4-16	0.44	0.38	0.38	1.75	1.50	0.43	0.75	5.00	0.63	0.88	0.75	2.88
2.000	0.750	1.250	3.00	3/4-16	0.66	0.56	0.63	1.75	1.50	0.57	1.25	5.25	1.13	1.38	1.13	2.88
2.500	0.750	1.250	3.50	3/4-16	0.66	0.56	0.63	1.75	1.50	0.57	1.25	5.38	1.13	1.38	1.13	3.00
3.250	1.000	1.625	4.50	1-1/16-12	0.88	0.75	0.75	2.00	1.75	0.72	1.50	6.25	1.38	1.84	1.50	3.50
4.000	1.375	2.188	5.00	1-1/16-12	1.19	1.03	0.88	2.00	1.75	0.72	2.13	6.63	1.94	2.25	2.06	3.75
5.000	1.750	2.813	6.50	1-1/16-12	1.53	1.31	0.88	2.00	1.75	1.00	2.25	7.13	2.06	2.88	2.69	4.25
6.000	2.000	3.188	7.50	1-5/16-12	1.75	1.50	1.00	2.25	2.25	1.14	2.50	8.38	2.31	3.31	3.06	4.88

\*Cylinder CD

\*\*Prior to 3/1/97, NPTF standard. Effective 3/1/97 SAE O-Ring straight thread ports are standard: see page 37 for sizes.

### Spherical "MU3" Bracket

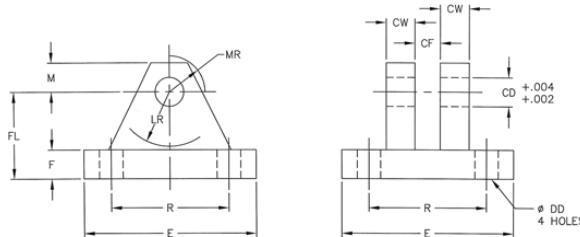

### Clevis Bracket - Spherical

Part Number	E	F	M	R	CD	CF	CW	DD	FL	LR	MR
R433078852	10.62	1.50	2.00	7.92	2.00	1.75	1.50	0.91	5.00	3.31	2.38
P-167198-00004	8.50	1.25	1.75	6.58	1.75	1.53	1.25	0.91	4.50	2.88	2.06
R433038164	6.50	0.88	1.38	4.95	1.38	1.19	1.00	0.66	3.58	2.44	1.62
R433038163	5.50	0.75	1.00	4.10	1.00	0.88	0.75	0.53	2.50	1.69	1.19
R433038162	3.75	0.62	0.88	2.76	0.75	0.66	0.62	0.53	2.00	1.38	1.00
R433038161	3.00	0.50	0.50	2.05	0.50	0.44	0.50	0.41	1.50	0.94	0.62

# Heavy Duty Pneumatic and Hydraulic NFPA Steel Cylinders

## AVENTICS PRESSUREMASTER® HHT HYDRAULIC CYLINDERS

### MX1 TIE RODS EXTENDED BOTH ENDS Bore Sizes 1-1/2"–6"

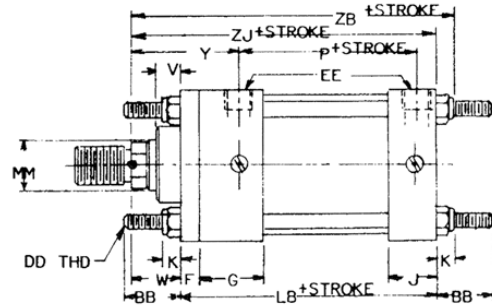
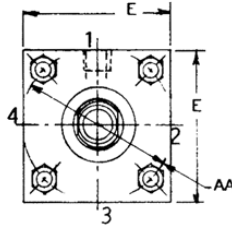
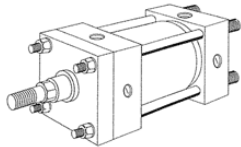

### MX2 TIE RODS EXTENDED CAP END ONLY Bore Sizes 1-1/2"–6"

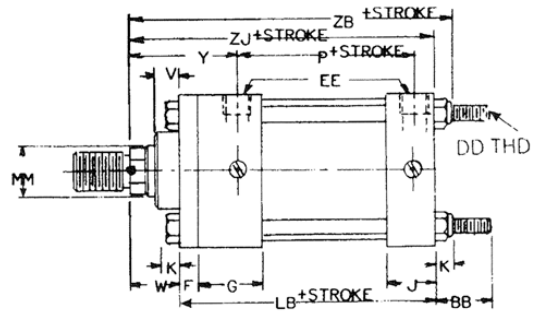
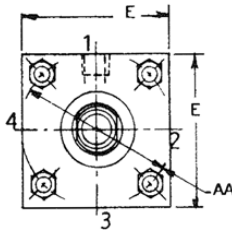
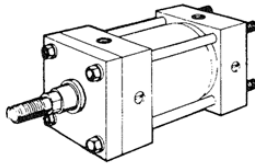

### MX3 TIE RODS EXTENDED HEAD END ONLY Bore Sizes 1-1/2"–6"

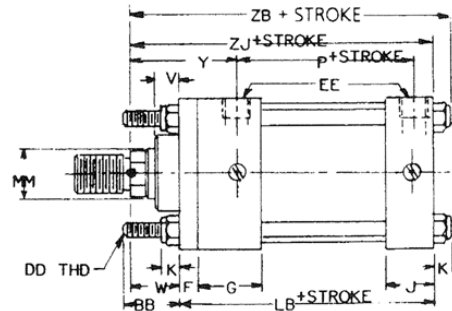
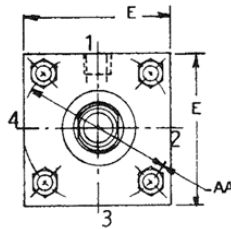
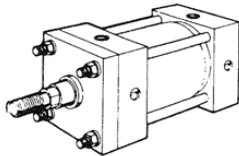

### MX4 TIE RODS EXTENDED TWO EACH END Bore Sizes 1-1/2"–6"

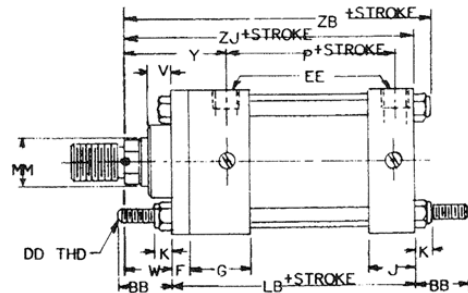
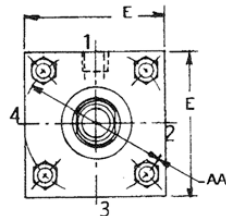
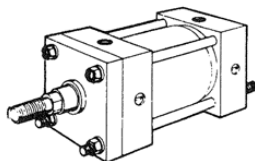

# Heavy Duty Pneumatic and Hydraulic NFPA Steel Cylinders

## AVENTICS PRESSUREMASTER® HHT HYDRAULIC CYLINDERS

### TIE ROD MOUNTS

**TABLE 1** - Dimensions affected by rod diameter.

BORE IN	MM ROD	V	W	Y	ZB	ZJ
1.500	0.625	0.25	0.63	2.00	6.06	5.63
	1.000	0.50	1.00	2.38	6.43	6.00
2.000	1.000	0.25	0.75	2.38	6.57	6.00
	1.375	0.38	1.00	2.63	6.82	6.25
2.500	1.000	0.25	0.75	2.38	6.70	6.13
	1.375	0.38	1.00	2.63	6.95	6.38
	1.750	0.50	1.25	2.88	7.20	6.63
3.250	1.375	0.25	0.88	2.75	7.85	7.13
	1.750	0.38	1.13	3.00	8.10	7.38
	2.000	0.38	1.25	3.13	8.22	7.50
4.000	1.750	0.25	1.00	3.00	8.35	7.63
	2.000	0.25	1.13	3.13	8.48	7.75
	2.500	0.38	1.38	3.38	8.73	8.00
5.000	2.000	0.25	1.13	3.13	9.26	8.25
	2.500	0.38	1.38	3.38	9.51	8.50
	3.000	0.38	1.38	3.38	9.51	8.50
	3.500	0.38	1.38	3.38	9.51	8.50
6.000	2.500	0.25	1.25	3.50	10.77	9.63
	3.000	0.25	1.25	3.50	10.77	9.63
	3.500	0.25	1.25	3.50	10.77	9.63
	4.000	0.25	1.25	3.50	10.77	9.63

Tie Rod and Flange Mounts are basically the same except that the tie rods are extended and used to mount the cylinder. To prevent misalignment, sagging or binding of the cylinder when long strokes are required, the free end of the cylinder should be supported. For thrust load applications, blind or cap end tie rod extensions are best. For tension load applications, rod or head end tie rod extensions are best. Tie rod mounts are suited for many applications, however, it should be noted that they are not as rigid as the flange mountings.

**NOTES:**

The bearing retainer plate is the same as the "E" dimension for 1-1/2"—6" bore sizes.

Rod end options shown on page 72.

**TABLE 2** - Dimensions not affected by rod diameter.

BORE IN	AA	BB	DD-THD	E	EE**	F	G	J	K	LB	P
1.500	2.30	1.38	0.38-24	2.50	3/4-16	0.38	1.75	1.50	0.43	5.00	2.88
2.000	2.90	1.81	0.50-20	3.00	3/4-16	0.63	1.75	1.50	0.57	5.25	2.88
2.500	3.60	1.81	0.50-20	3.50	3/4-16	0.63	1.75	1.50	0.57	5.38	3.00
3.250	4.60	2.31	0.63-18	4.50	1-1/16-12	0.75	2.00	1.75	0.72	6.25	3.50
4.000	5.40	2.31	0.63-18	5.00	1-1/16-12	0.88	2.00	1.75	0.72	6.63	3.75
5.000	7.00	3.19	0.88-14	6.50	1-1/16-12	0.88	2.00	1.75	1.00	7.13	4.25
6.000	8.10	3.63	1.00-14	7.50	1-5/16-12	1.00	2.25	2.25	1.14	8.38	4.88

\*\*Prior to 3/1/97, NPTF standard. Effective 3/1/97 SAE O-Ring straight thread ports are standard; see page 37 for sizes.



# Heavy Duty Pneumatic and Hydraulic NFPA Steel Cylinders

## AVENTICS PRESSUREMASTER® HHT HYDRAULIC CYLINDERS

### HOW TO ORDER

EXAMPLES (A) 2 x 10 C-MP1-HHT-C;  
1" Rod, 3/4" - 16 M. Threads

(B) 6 x 48 Effective Stroke, C-MP1-HHT-C; 4" rod, 3" - 12 Male  
Threads, 6" Stop Tube. See pages 68 and 69 to calculate  
stop tube length and rod diameter.

NOTE: Effective 3/1/97, SAE O-Ring Straight thread ports  
standard on HHT cylinders.

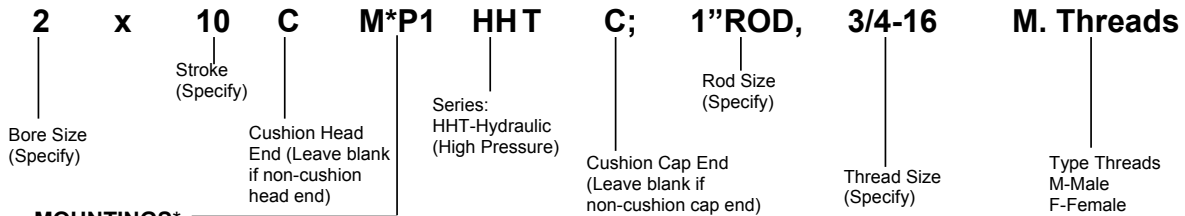

#### MOUNTINGS\*

Head Rectangle	ME5
Cap Rectangle	ME6
Head Rectangular Flange (1-1/2"—6")	MF1
Cap Rectangular Flange (1-1/2"—6")	MF2
Head Square Flange	MF5
Cap Square Flange	MF6
Cap Fixed Clevis	MP1
Cap Detachable Clevis (1-1/2"—6")	MP2
Fixed Pivot	MP3
Detachable Pivot(1-1/2"—6")	MP4
Side Lug	MS2
Center Line Lug (1-1/2"—6")	MS3
Side Tap	MS4
Side End Lug (1-1/2"—6")	MS7
Head End Trunnion	MT1
Cap End Trunnion	MT2
Intermediate Fixed Trunnion (Specify XI)	MT4
Universal Clevis (1-1/2"—6")	MU3
Tie Rod Mounting	MX0,1, 2, 3, 4

\* Double Rod End (Example: MDE3)  
(Specify only when required, available  
in most mountings. 1-1/2, 2, 2-1/2 bore  
cylinders with the maximum oversize  
rod and head cushion marked in dimension  
tables, have no head cushion adjustment or  
check valve bypass. These models:  
are not recommended for double rod  
end application.)

#### OPTIONS (Specify)

- Seals - Standard, Viton
- Polypak Piston Seals
- Cast Iron Piston Rings
- Piston Rod Studs
- Rod Extension ("W" dimension)
- Thread Extension ("A" dimension)
- Stop Tube (Specify effective stroke)
- Piston Rod Material (Stainless Steel)
- Port Location & Number of Cushions
- Rod Boot
- Stroke Adjustment
- Port Style: SAE O-ring (std.), NPTF, SAE 4 Bolt Flange
- Thrust Key Head Plate
- Proximity Switches
- Epoxy Paint
- Special Items as required

#### OPERATING PRESSURES (PSI) BY CYLINDER BORE SIZES\*\*

CYLINDER BORE	STANDARD ROD	NOMINAL	NON-SHOCK
1-1/2	5/8		
2	1		
2-1/2	1		
3-1/4	1-3/8		
4	1-3/4		
5	2	3,000	5,000
6	2-1/2		
7	3		
8	3-1/2		
10	5		
12	5-1/2		
14	7		

\*\*1) For flange mounted and double rod cylinders; see  
pages 42 and 44

2) Exceptions to 5000 psi non-shock rating:

- A) 1-1/2" bore with 5/8" rod, all mounts.
- B) All bore sizes using the following mounts:  
MT1, MT2, MT4, MF1, MF2, ME5, ME6, MS7
- C) The following mounts for bore sizes listed:  
MP1: 2-1/2", 12", 14"  
MP2: 2-1/2", 8"  
MU3: 2-1/2", 3-1/4"  
MS2 & MS3: 10", 12", 14"  
MS4: 14"  
MF5 & MF6: 6" thru 10"  
MX0, MX1, MX2, MX3, MX4: for 10" and larger,  
consult factory

# Heavy Duty Pneumatic and Hydraulic NFPA Steel Cylinders

## AVENTICS PRESSUREMASTER® HHT HYDRAULIC CYLINDERS

### INSTALLATION AND SERVICE INFORMATION 1-1/2"–14" BORE STANDARD SPECIFICATIONS

OPERATING PRESSURES (PSI) BY CYLINDER BORE SIZES\*

CYLINDER BORE	STANDARD ROD	HEAVY DUTY	
		NOMINAL	NON-SHOCK
1-1/2	5/8	3,000	5,000
2	1		
2-1/2	1		
3-1/4	1-3/8		
4	1-3/4		
5	2		
6	2-1/2		
7	3		
8	3-1/2		
10	5		
12	5-1/2		
14	7		

\* See page 55 for pressure limitations. For flange-mounted and double rod end cylinders, see pages 42 and 44

**Duty**— 3000 psi hydraulic, 5000 psi non-shock, except as noted.

**Standards**—Meets or exceeds all J.I.C. and NFPA requirements.

**Bore Sizes**—1-1/2"–14" (standard)

**Piston Rods**—5/8"–7" (standard)

**Mountings**—22 standard NFPA mountings.

**Temperature Range**— -65°F to +200°F (Buna-N standard seals). Optional Viton® seals for -15° to 400°F and many fluids.

#### APPROXIMATE UNCRATED PRESSUREMASTER HYDRAULIC CYLINDER WEIGHTS (LBS.)\*

Cylinder Bore	1-1/2	2	2-1/2	3-1/4	4	5	6	7	8	10	12	14
Zero Stroke	7.5	10	16	31	41	73	138	180	310	610	970	1520
Add Per Inch of Stroke	.5	.7	1.17	1.75	2.5	4.0	5.2	6.2	8.7	15.2	21.6	28.5

\*Weights based on standard (first) rod sizes

**WARNING**— Read and follow warnings and directions as listed on the inside back cover of this catalog prior to performing any service or installation.

**INSTALLATION**—For outline dimensions and other considerations in mounting the PressureMaster, see pages 41 - 54. Before mounting the cylinder, be sure all hydraulic lines leading to the cylinder are free of dirt and foreign matter. An accumulation of foreign matter in the supply lines can cause corrosion, less efficient cylinder operation, and shorter cylinder life. A very important consideration in mounting the PressureMaster is keeping the cylinder thrust as close as possible to the centerline of the piston rod and free of misalignment or side thrust. Off-center thrust or side loads decrease the normal life of the rod bearing and seals and can cause binding in the cylinder or linkage. Forcing rod, clevis pins, or mounting bolts into position indicates that the cylinder is not properly aligned, and permanent damage may result from such installation.

**Side Lugs (MS2), Centerline Lugs (MS3) and Side Tapped (MS4):** After a cylinder utilizing one of the above mounts has been aligned, key or pin it to its support. Properly located shear keys or pins will absorb the major portion of the shear load. Always use high-tensile bolts to fasten the cylinder to its support.

**Head Rectangular Flange (MF1, ME5), Cap Rectangular Flange (MF2, ME6), Head Square Flange (MF5) and Cap Square Flange (MF6):** A flange-mounted cylinder can be centered by using the gland in the cylinder head as a pilot. After mounting and alignment, the cylinder should be dowelled to its support to prevent shifting. For installation producing high stock loads or utilizing maximum operating pressures, a square flange is recommended.

**Head Trunnion (MT1), Cap Trunnion (MT2) and Intermediate Fixed Trunnion (MT4):** Install a trunnion-mounted cylinder in rigid, accurately aligned pillow blocks. These blocks should be well lubricated at all times. Since trunnion pins are designed for shear loads only, provide linkage with a suitable pivot for connection to the rod end of the cylinder.

**Fixed Clevis (MP1), Detachable Clevis (MP2) and Universal Clevis (MU3):** In the installation of clevis-mounted cylinder, the centerline of the pivot pin in the rod end linkage must be parallel with the centerline of the clevis pin in the cap end of the cylinder. A universal clevis mount automatically compensates for 5 to 10 degrees of misalignment in any direction. Never allow the cylinder head or cap to stop the piston at the end of its stroke. Either provide external stops to prevent the piston from bottoming or use a cylinder with built-in cushioning. A cushioned cylinder will stop the piston just before it reaches the end of its stroke. Under certain conditions of load, external stops may be required to supplement the cylinder cushioning.

**OPERATION** — The standard PressureMaster cylinder has an operating temperature range of -65° to +200°F. For operating temperatures above and below this range, special seals are required. Maximum operating pressure of the cylinder is 3000 psi, except some flange mounted and double rod end cylinders, see pages 42 and 44 for limitations. The PressureMaster cylinder is designed operation with petroleum based hydraulic fluids. Operation using fire-resistant phosphate esters or other special types of fluids requires special packing and seals. Hydraulic pressure supplied to the cap-end port moves the piston rod to its extended position. Pressure supplied to the head end port moves the piston rod to its retracted position. See pages 62 and 63 for forces developed by each cylinder.

**ADJUSTMENT**— A non-cushioned cylinder requires no further adjustment after it has been installed and properly aligned. A cushion cylinder, after installation and alignment, must be adjusted to obtain the degree of cushioning desired. An adjustment is provided by a screw-type needle and check valve in either or both ends of the cylinder. This Exact-a-just™ valve controls the rate at which trapped fluid is allowed to drain from the end of the cylinder when the piston is near the end of its stroke. Turn the needle valve clockwise to increase the amount of cushioning. Turn it counter-clockwise to decrease cushioning. To obtain the most effective cushioning, final adjustment must be made while the cylinder is operating under normal conditions at normal operating pressure.

# Heavy Duty Pneumatic and Hydraulic NFPA Steel Cylinders

## AVENTICS PRESSUREMASTER® HHT HYDRAULIC CYLINDERS

### MAJOR REPAIR, MAINTENANCE & TESTING

#### GENERAL MAINTENANCE & REPAIR RECOMMENDATIONS

Maintenance periods should be scheduled in accordance with frequency of use and working environment of the cylinder. All cylinders must be visually inspected for wear and given an "in system" operating performance and leakage test at least once a year. If these visual observations indicate cylinder repair is required, the cylinder must be removed, repaired and tested. A major overhaul is recommended at one million cycles. However, where frequency of use is such that it would require more than two years to obtain one million cycles, the cylinder must be overhauled at the two year period. When it is determined that the cylinder requires a major repair as a result of the one million cycles, one year routine inspection, or the two year service period has elapsed, the device must be disassembled, cleaned, inspected, parts replaced as required, rebuilt and tested for leakage and proper operation prior to installation.

#### MAJOR REPAIR & MAINTENANCE INSTRUCTION

Always drain the pressure from a hydraulic system before performing any service work. Disconnect hydraulic lines from head and cap ports of cylinder. Completely disassemble the cylinder using the exploded and assembly views as reference. No special tools are required except internal snap ring pliers. The piston rod assembly consisting of rod, piston and head cushion bushing (where used) are torqued and secured at the factory and are not to be disassembled (cylinders built prior to 1986 utilized piston nut, ref. item 18). After disassembling the cylinder, wash all metal parts in a non-flammable solvent. Rinse each part thoroughly and blow dry with a low pressure air jet. Arrange the parts on a clean surface. Examine each part carefully. Replace all rubber parts and other worn or damaged parts. The use of Repair Kits is strongly recommended. Particular attention should be given to the rod bearing (5a) since cylinder leakage can result from a worn bearing. A scored or rough rod bearing might damage the piston rod and, subsequently, the rod packing. Rod cartridge kits are available with or without the rod bearing. An excellent feature of the PRESSUREMASTER hydraulic cylinder is easy replacement of the rod cartridge (5) without loosening the tie rods. On most cylinders with bore sizes from 1-1/2" - 6 inches, remove the screws and washers (1 & 2) and retainer plate (4a). For all cylinders with bore sizes 7 through 14 inches, remove screws (3) and retainer plate (4b). The rod cartridge is easily removed from the cylinder head. To facilitate removal, a screwdriver can be used to pry in the external groove.

#### REASSEMBLY

The procedure for reassembly is essentially the reverse of the disassembly. However, the following exceptions should be noted: Lubricate inside diameter of cylinder tube and piston rod with hydraulic fluid used in cylinder application. SEALS: Lubricate all seals with hydraulic fluid used in cylinder application. The hydraulic fluid specified for use in the cylinder is the only lubricant to be used in assembly. In reassembling the cylinder, use the exploded and assembly views as reference. Be careful not to cut or damage the rod packing and seals. The tie rod threads should be well lubricated to allow tightening the nuts evenly for proper pre-stressing. To avoid twisting of the tie rod during tightening, hold with vise grip or clamp. To assure equal pre-stressing of tie rods, first turn on nuts even and snug to align assembly, then the nuts are to be tightened alternately. For proper tie rod pre-stressing, they should be torqued as recommended. The specific torque value is determined by the diameter of the tie rod. For lubricated tie-rod threads, see chart above:

CYL. BORE SIZE	TIE ROD DIAMETER	TORQUE-LUBRICATED LBS.-FOOT		
		Prior to March 1992	As of March '92	
			"P" Part No.	"C" Part No.
All mounts except MF1, MF2, MF5, MF6 and MS7:				
1-1/2"	3/8"	19	19	20
2"	1/2"	45	45	35
2-1/2"	1/2"	45	45	55
3-1/4"	5/8"	90	90	110
4"	5/8"	90	125	125
5"	7/8"	255	295	345
6"	1"	360	480	545
7"	1-1/8"	450	720	775
8"	1-1/4"	750	1050	1075
10"	1"(uses 12)	360	425	500
12"	1"(uses 16)	360	460	500
14"	1"(uses 20)	360	500	500
For mounts MF1, MF2, MF5, MF6 and MS7:				
1-1/2"	3/8"	19	19	20
2"	1/2"	45	45	35
2-1/2"	1/2"	45	45	55
3-1/4"	5/8"	90	90	110
4"	5/8"	90	90	125
5"	7/8"	255	225	258
6"	1"	360	360	400
7"	1-1/8"	450	450	480
8"	1-1/4"	750	750	770
10"	1"(uses 12)	360	360	390
12"	1"(uses 16)	360	360	390
14"	1"(uses 20)	360	360	390

#### TESTING

After the cylinder has been completely reassembled, it should be tested, either on a test bench or in the regular installation.

#### TEST PROCEDURES (see maximum psi/bore)

The cylinder should be tested for cushioning, travel and leakage.

#### A. Cushioning (if applicable)

1. Turn both cushioning screws clockwise all the way in.
2. Cycle cylinder a few times by alternating supply pressure to head and cap ports.
3. Apply supply pressure to the head port. Rod should retract, decelerate and may stop before completion of stroke.
4. Apply supply pressure to the cap port. Rod should extend, decelerate and may stop before completion of stroke.

#### B. Travel and Leakage

1. Turn the cushioning screws counterclockwise one full turn.
2. Apply supply pressure to the head port. Rod should retract smoothly without binding. Cylinder should retract, have less cushioning and make full stroke + or - 0.062". Check leakage at cap port, no leakage permitted. Check leakage around rod seal. No leakage permitted.
3. Apply supply pressure to the cap port. Rod should extend smoothly without binding. Cylinder should extend, have less cushioning and make full stroke + or - 0.062". Check leakage at head port, no leakage permitted.
4. Return piston rod to retract position by applying supply pressure to head port. Remove supply pressure and install cylinder in service if satisfactory.

#### CUSHION ADJUSTMENT

Turn the needle valve clockwise to increase the amount of cushioning and counter-clockwise to decrease cushioning. To obtain the most effective cushioning, final adjustment must be made while the cylinder is operating under normal conditions at normal operating pressure.

# Heavy Duty Pneumatic and Hydraulic NFPA Steel Cylinders

## AVENTICS PRESSUREMASTER® HHT HYDRAULIC CYLINDERS

1-1/2" — 14" BORE

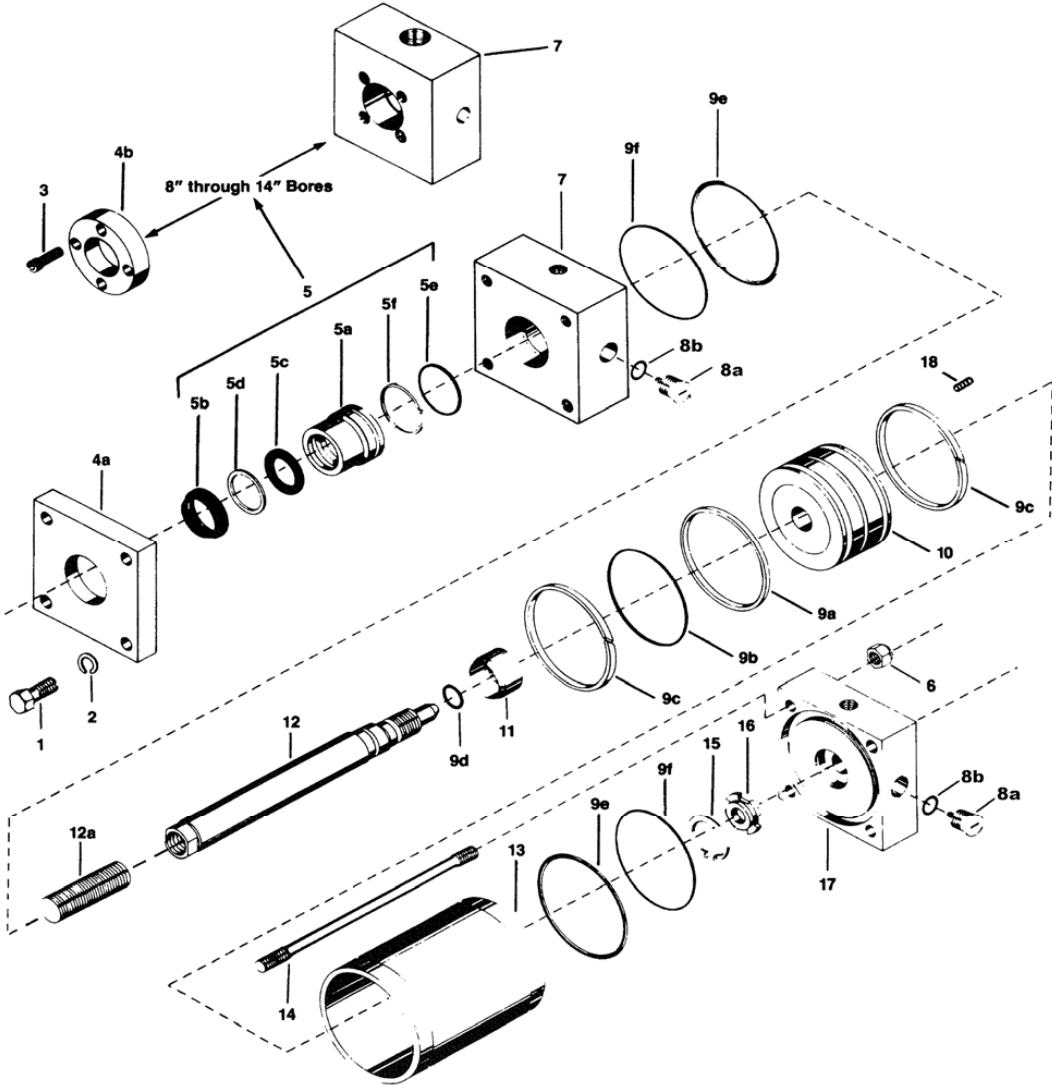

1-1/2" through 6" bores

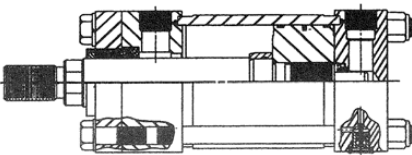

7" through 14" bores

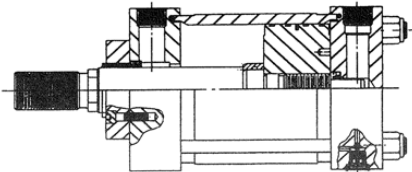

# Heavy Duty Pneumatic and Hydraulic NFPA Steel Cylinders

## AVENTICS PRESSUREMASTER® HHT HYDRAULIC CYLINDERS

### 1-1/2" — 14" BORE

REF.	DESCRIPTION	CUSHIONED BOTH ENDS	CUSHIONED HEAD ONLY	CUSHIONED CAP ONLY	NON-CUSHIONED
1	SCREW, Cap (1-1/2"—6" bore sizes)	4	4	4	4
2	WASHER, Lock (1-1/2"—6" bore sizes)	4	4	4	4
3	SCREW, Socket Head Cap (7"—14" bore sizes)	4†	4†	4†	4†
4a	PLATE, Retainer (1-1/2"—6" bore sizes)	1	1	1	1
4b	PLATE, Retainer (7"—14" bore sizes)	1	1	1	1
* 5	CARTRIDGE, Rod Kit	1	1	1	1
5a	BEARING, Rod	1	1	1	1
5b	WIPER, Rod	1	1	1	1
5c	PACKING, U-cup/O-ring	1	1	1	1
5d	RING, Rod Packing Backup	1	1	1	1
5e	RING, Rod Bearing O-ring	1	1	1	1
5f	RING, Backup	1	1	1	1
\$ 6	NUT, Tie Rod Lock	4†	4†	4†	4†
7	HEAD	1	1	1	1
* 8	CUSHION, Needle Valve Kit	2	1	1	—
8a	VALVE, Exact-a-just™ Needle & Check	2	1	1	—
8b	RING, Needle Valve O-ring	2	1	1	—
*#9	PISTON & TUBE, Seal Kit	1	1	1	—
9a	RING, Piston Bearing Seal	1	1	1	1
9b	RING, Piston Bearing O-ring	1	1	1	1
9c	RING, Piston Bearing Guide	2†	2†	2†	2†
9d	RING, Piston Bearing O-ring	1	1	1	1
9e	RING, End Cover O-ring	2	2	2	2
9f	RING, Backup	2	2	2	2
10	PISTON	1	1	1	—
11	BEARING, Head Cushion	1	1	—	—
12	ROD, Female Piston	1	1	1	1
12a	ADAPTER, Male Piston Rod (when required)	1	1	1	1
13	TUBE, Cylinder	1	1	1	1
14	TIE ROD	4†	4†	4†	4†
15	RING, Cap Cushion Retaining	1	—	1	—
* 16	INSERT, Cap Cushion Seal	1	—	1	—
17	CAP	1	1	1	1
•	Not shown: NUT, Piston Bearing Retaining (1-1/2"—5" bore	1	1	1	1
• 18	SCREW, Socket Head Set (6"—14" bore sizes)	1	1	1	1

- \* Recommended spare parts to be retained in stock at all times, † Quantity may be greater depending on mounting style and bore size.
- See "Repair Kits", § As of March 1992, 1-1/2" thru 8" bore have Grade 8 nut and lockwasher
- Not standard after 1984 § Not used after 1995.
- # See Piston and Tube Seal Kit part numbers, page 60.

### REPAIR KITS

Repair parts included in the following repair kits are available only in kit form. Kits should be ordered by kit part numbers plus cylinder part number when possible. Other parts not included in repair kits MUST be ordered separately by reference number, description, and cylinder part number. Some kits may have an excess of parts not used in some models. Discard these parts or keep for later use.

#### Rod Cartridge Kit (with Rod Bearing)

Rod Diameter	Bore Size	Urethane (Std.) Part Number	Viton® Part Number
0.63"		R433022023	R433041184
1.00"		R433022025	R433033115
1.38"		R433022027	R433033112
1.75"		R433022029	R433041191
2.00"		R433022031	R433041203
2.50"		R433022033	R433023964
3.00"		R433022035	R433033105
3.50"	6, 7, & 8	R433023458	R433024259
3.50"	5	R433024861	R433041235
4.00"		R433024161	R433024263
4.50"	8	R433073139	R433040358
4.50"	10	R433034135	R433033477
5.00"	7 & 8	R433024192	R433024327
5.00"	10	R433014544	R433024267
5.50"	8	R433024323	R433024329
5.50"	10 & 12	R433023462	R433024271
7.00"	10	R433024325	
7.00"	12 & 14	R433024256	
8.00"	12	R433039747	
8.50"	12	R433024278	

Includes Ref. items: 5a, 5b, 5c, 5d, 5e & 5f

#### Rod Seal Kit (whitout Rod Bearing)

Rod Diameter	Urethane Part Number	Viton Part Number
0.63"	R433023933	R433041186
1.00"	R433023939	R433033116
1.38"	R433023943	R433033111
1.75"	R433023949	R433041189
2.00"	R433023955	R433041201
2.50"	R433023961	R433023963
3.00"	R433023967	R433033107
3.50"	R433014992	R433041233
3.50"	R433014992	R433041233
4.00"	R433024276	R433024265
4.50"	R433034106	R433040356
5.00"	R433014997	R433032988
5.00"	R433014997	R433032988
5.50"	R433014999	R433024273
5.50"	R433014999	R433024273
7.00"	R433024257	R433024275
7.00"	R433024257	R433024275
8.00"	R433039748	R433033372
8.50"	R433024278	

Includes Ref. items 5b, 5c, 5d, 5e & 5f

#### Cushion Needle Valve Assemblies (Exact-a-just™)

BUNA N Part Number	Viton® Part Number	Bore Size
R433015236	R433072609	1.5", 2", 2.5"
R433016568	R433074773	3.25", 4", 5"
R433023256	R433023256	6" thru 14"

Includes Ref. Items 8a & 8b.

#### Cap Cushion Seal BUNA N\*

Bore Size	Part Number	Bore Size	Part Number
1.50"	R433015116	6.00"	R433015117
2.00"	R433015115	7.00"	R433015117
2.50"	R433015115	8.00"	R433015118
3.25"	R433015115	10.00"	R433015119
4.00"	R433015115	12.00"	R433015119
5.00"	R433015115	14.00"	R433015119

Ref. Item 16

# Heavy Duty Pneumatic and Hydraulic NFPA Steel Cylinders

## AVENTICS PRESSUREMASTER® HHT HYDRAULIC CYLINDERS

### Piston and Tube Seal Kit Part Numbers

Bore In	MM Rod	BN		VV		PP		PV	
		C Teflon, Buna	P Teflon, Buna	C Teflon, Viton	P Teflon, Viton	C Polypak, Buna	P Polypak, Buna	C Polypak, Viton	P Polypak, Viton
1.5	0.625	R433002317	R433024194	R433002343	R433024220	R433005114	R433040156		
	1	R433002318	R433024195	R433002344	R433024221	R433012121	R433055223		
2	1	R433002321	R433024199	R433002347	R433024224	R433004606	R433039113		
	1.375	R433002321	R433024199	R433002347	R433024224	R433004606	R433039113		
2.5	1	R433002323	R433024201	R433002349	R433024226	R433011752	R433054449	R433003135	R433039987
	1.375	R433002323	R433024201	R433002349	R433024226	R433011752	R433054449	R433003135	R433039987
	1.75	R433002431	R433024696	R433002501	R433030922	R433004662	R433040425		
3.25	1.375	R433002325	R433024203	R433002351	R433024228	R433004625	R433039401		
	1.75	R433002325	R433024203	R433002351	R433024228	R433004724	R433039401		
	2	R433003835	R433034061	R433002577	R433030922	R433004711	R433039361		
4	1.75	R433002327	R433024205	R433002353	R433024230	R433011726	R433054281	R433004998	R433039989
	2	R433002327	R433024205	R433002353	R433024230	R433011726	R433054281	R433004998	
	2.5	R433002415	R433024556	R433003932	R433034231	R433077813	R433040425		
5	2	R433002329	R433024207	R433002355	R433024232	R433011754	R433054451	R433004994	
	2.5	R433002329	R433024207	R433002355	R433024232	R433011754	R433054451	R433004994	
	3	R433002435	R433024698	R433002535	R433025166	R433072332	R433054368		
6	2.5	R433002331	R433024209	R433002357	R433024234	R433004600	R433039100		R433040148
	3	R433002331	R433024209	R433002357	R433024234	R433004600	R433039100		R433040148
	3.5	R433002388	R433024379	R433002799	R433032903	R433004652	R433039229		
7	4	R433002388	R433024379	R433002799	R433032903	R433004652	R433039229		
	3	R433002428	R433024211	R433002359	R433024236	R433005367			
	3.5	R433002428	R433024211	R433002359	R433024236	R433005367			
8	4	R433002333	R433074967		R433040526				
	5	R433002333	R433074967		R433040526				
	3.5	R433002335	R433024213	R433002361	R433024238				
10	4	R433002335	R433024213	R433002361	R433024238				
	4.5	R433002335	R433024213	R433002361	R433024238				
	5	R433002455	R433024805	R433002503	R433074971				
12	5.5	R433002455	R433024805	R433002503	R433074971				
	4.5	R433002337	R433024215	R433003057	R433024240	R433072202			
	5	R433002337	R433024215	R433003057	R433024240	R433072202			
14	5.5	R433002337	R433024215	R433003057	R433024240	R433072202			
	7	R433073898	R433024217		R433024242				
	8	R433005118	R433040191		R433040414				
14	7	R433002340	R433024219		R433040414				
	10		R433040703						

Note: "C" kit part numbers refers to new tube design cylinders. If kit part number is not shown, contact factory.  
For cylinder part numbers beginning with "C" or "R" use the "C" version kit. For cylinder part numbers beginning with "W" or "P", use the "P" version kit.

### SIZING

The total load or force expected of the cylinder must be known in order to properly size a cylinder. If it is estimated, it should be on the high side. On air applications, considerably more force must be available than total load for the best operation. The surplus force is transferred into velocity, or it is counterbalanced with back pressure to control velocity. In selecting the MINIMUM force recommended for an application, the following general guidelines apply:

AIR CYLINDERS	FOR GENERAL APPLICATIONS	— minimum force available from the cylinder should be 125% of the total load.
	FOR SPEED CONTROL	— minimum force available from the cylinder should be 150% of the total load.
	FOR MAXIMUM VELOCITY	— minimum force available from the cylinder should be 200% of the total load.
HYDRAULIC CYLINDERS	FOR GENERAL APPLICATIONS	— minimum force available from the cylinder should be 110% of the total load.

### FLOW REQUIRED BY CYLINDERS

The flow required to operate a cylinder at a given speed is very often one of the controlling factors in an application. Again, the pneumatic cylinder is more complex and represents an approximation. The following formulas may be useful:

#### HYDRAULIC FLOW REQUIRED

$$GPM = \frac{Dh \times S \times 60}{T}$$

Where GPM=Flow required in gallons per minute

Dh= Displacement of cylinder in gallons per inch of stroke, see catalog chart

S= Stroke of cylinder, inches

T= Time in seconds to complete above stroke

#### PNEUMATIC FLOW REQUIRED (Average)

SCFM avg= C x Dp x S x SPM where

SCFM avg= Average ft<sup>3</sup> free air per minute required

Dp= Displacement of cylinder in ft<sup>3</sup> per inch of stroke

S= Stroke in inches

SPM=Strokes per minute, count both in and out strokes

C= Conversion factor for air compression, ratio

$$C = \frac{\text{Supply pressure (psig)} + 14.7}{14.7}$$

#### CYLINDER SPEED

For adequate seal life, the cylinder linear velocities should be limited to a maximum of 20 inches per second per second for lip-type seal.\* On hydraulic cylinders, the speed is controlled by the GPM capacity of the pump or valves and line size. The speed of

pneumatic cylinders is difficult to predict, and an average based on the total stroke time is normally used as an estimate. The following formulas may be useful.

\* Increased velocity can be realized with different seal arrangement. Contact factory for information.

#### HYDRAULIC CYLINDER SPEED

$$Vh = \frac{GPM}{Dh \times 720}$$

Vh= Cylinder Speed fps

GPM= Gallons per minute flow supplied

Dh= Displacement of cylinder in gallons per inch of stroke (see catalog chart)

#### PNEUMATIC CYLINDER SPEED

$$Vp = \frac{S}{T \times 12}$$

Vp= Cylinder Speed fps

S= Stroke, in.

T= Time to complete above stroke in seconds

#### CAUTION: OVERSIZE PORTS

Full flow diameters of oversize ports may not be obtainable with standard cylinder geometry. Consult factory



# Heavy Duty Pneumatic and Hydraulic NFPA Steel Cylinders

## AVENTICS CYLINDER APPLICATION DATA

### CAPACITY CHART PER INCH OF STROKE

BORE INCH	MM ROD DIA.	CUBIC IN/INCH		CUBIC FEET/INCH		GALLONS/INCH		LITERS/INCH		CC/INCH	
		STROKE	STROKE	STROKE	STROKE	STROKE	STROKE	STROKE	STROKE	STROKE	STROKE
		PUSH	PULL	PUSH	PULL	PUSH	PULL	PUSH	PULL	PUSH	PULL
1.500	0.625	1.77	1.46	0.00102	0.00085	0.00766	0.00633	0.02901	0.02398	29.016	23.987
	1.000	1.77	0.98	0.00102	0.00057	0.00766	0.00426	0.02901	0.01613	29.016	16.141
2.000	0.625	3.14	2.83	0.00182	0.00164	0.01359	0.01226	0.05146	0.04643	51.475	46.446
	1.000	3.14	2.35	0.00182	0.00136	0.01359	0.01019	0.05146	0.03859	51.475	38.600
	1.375	3.14	1.66	0.00182	0.00096	0.01359	0.00716	0.05146	0.02712	51.475	27.133
2.500	0.625	4.91	4.60	0.00284	0.00266	0.02126	0.01993	0.08046	0.07543	80.492	75.462
	1.000	4.91	4.12	0.00284	0.00239	0.02126	0.01786	0.08046	0.06759	80.492	67.616
	1.375	4.91	3.43	0.00284	0.00198	0.02126	0.01483	0.08046	0.05613	80.492	56.149
	1.750	4.91	2.50	0.00284	0.00145	0.02126	0.01084	0.08046	0.04105	80.492	41.061
3.250	1.000	8.30	7.51	0.00480	0.00435	0.03593	0.03253	0.13601	0.12314	136.066	123.190
	1.375	8.30	6.82	0.00480	0.00394	0.03593	0.02950	0.13601	0.11168	136.066	111.723
	1.750	8.30	5.89	0.00480	0.00341	0.03593	0.02552	0.13601	0.09660	136.066	96.635
	2.000	8.30	5.16	0.00480	0.00299	0.03593	0.02233	0.13601	0.08453	136.066	84.564
4.000	1.000	12.57	11.78	0.00727	0.00682	0.05442	0.05102	0.20599	0.19312	206.066	193.190
	1.375	12.57	11.09	0.00727	0.00641	0.05442	0.04799	0.20599	0.18165	206.066	181.723
	1.750	12.57	10.16	0.00727	0.00588	0.05442	0.04400	0.20599	0.16657	206.066	166.635
	2.000	12.57	9.43	0.00727	0.00546	0.05442	0.04082	0.20599	0.15451	206.066	154.564
	2.500	12.57	7.66	0.00727	0.00443	0.05442	0.03317	0.20599	0.12555	206.066	125.594
5.000	1.000	19.64	18.85	0.01137	0.01091	0.08502	0.08162	0.32185	0.30898	321.967	309.092
	1.375	19.64	18.16	0.01137	0.01051	0.08502	0.07859	0.32185	0.29751	321.967	297.625
	1.750	19.64	17.23	0.01137	0.00997	0.08502	0.07461	0.32185	0.28243	321.967	282.536
	2.000	19.64	16.50	0.01137	0.00955	0.08502	0.07142	0.32185	0.27036	321.967	270.466
	2.500	19.64	14.73	0.01137	0.00853	0.08502	0.06377	0.32185	0.24140	321.967	241.496
6.000	3.000	19.64	12.57	0.01137	0.00728	0.08502	0.05442	0.32185	0.20601	321.967	206.089
	1.375	28.25	26.77	0.01635	0.01549	0.12229	0.11587	0.46294	0.43861	463.115	438.772
	1.750	28.25	25.84	0.01635	0.01496	0.12229	0.11188	0.46294	0.42352	463.115	423.684
	2.000	28.25	25.11	0.01635	0.01453	0.12229	0.10869	0.46294	0.41146	463.115	411.613
	2.500	28.25	23.34	0.01635	0.01351	0.12229	0.10104	0.46294	0.38250	463.115	382.643
	3.000	28.25	21.18	0.01635	0.01226	0.12229	0.09169	0.46294	0.34711	463.115	347.236
	3.500	28.25	18.63	0.01635	0.01078	0.12229	0.08064	0.46294	0.30528	463.115	305.391
	4.000	28.25	15.68	0.01635	0.00908	0.12229	0.06789	0.46294	0.25701	463.115	257.108
7.000	3.000	38.49	31.42	0.02227	0.01818	0.16662	0.13602	0.63075	0.51491	630.984	515.105
	3.500	38.49	28.87	0.02227	0.01671	0.16662	0.12497	0.63075	0.47308	630.984	473.260
	4.000	38.49	25.92	0.02227	0.01500	0.16662	0.11222	0.63075	0.42482	630.984	424.977
	5.000	38.49	18.86	0.02227	0.01091	0.16662	0.08162	0.63075	0.38998	630.984	309.098
	1.375	50.27	48.79	0.02909	0.02823	0.21762	0.21119	0.82379	0.79945	824.098	799.756
8.000	1.750	50.27	47.86	0.02909	0.02770	0.21762	0.20721	0.82379	0.78437	824.098	784.667
	2.000	50.27	47.13	0.02909	0.02727	0.21762	0.20402	0.82379	0.77231	824.098	772.597
	2.500	50.27	45.36	0.02909	0.02625	0.21762	0.19637	0.82379	0.74335	824.098	743.627
	3.000	50.27	43.20	0.02909	0.02500	0.21762	0.18702	0.82379	0.70795	824.098	708.220
	3.500	50.27	40.65	0.02909	0.02352	0.21762	0.17597	0.82379	0.66612	824.098	666.375
	4.000	50.27	37.70	0.02909	0.02182	0.21762	0.16322	0.82379	0.61786	824.098	618.092
	4.500	50.27	34.37	0.02909	0.01989	0.21762	0.14877	0.82379	0.56316	824.098	563.371
	5.000	50.27	30.64	0.02909	0.01773	0.21762	0.13262	0.82379	0.50202	824.098	502.213
10.000	5.500	50.27	26.51	0.02909	0.01534	0.21762	0.11477	0.82379	0.43445	824.098	434.617
	1.750	78.54	76.13	0.04545	0.04406	0.34000	0.32959	1.28706	1.24764	1287.541	1248.110
	2.000	78.54	75.40	0.04545	0.04363	0.34000	0.32640	1.28706	1.23557	1287.541	1236.039
	2.500	78.54	73.63	0.04545	0.04261	0.34000	0.31875	1.28706	1.20661	1287.541	1207.070
	3.000	78.54	71.47	0.04545	0.04136	0.34000	0.30940	1.28706	1.17122	1287.541	1171.662
	3.500	78.54	68.92	0.04545	0.03988	0.34000	0.29835	1.28706	1.12939	1287.541	1129.817
	4.000	78.54	65.97	0.04545	0.03818	0.34000	0.28560	1.28706	1.08113	1287.541	1081.534
	4.500	78.54	62.64	0.04545	0.03625	0.34000	0.27115	1.28706	1.02643	1287.541	1026.814
	5.000	78.54	58.91	0.04545	0.03409	0.34000	0.25500	1.28706	0.96529	1287.541	965.656
	5.500	78.54	54.78	0.04545	0.03170	0.34000	0.23715	1.28706	0.89772	1287.541	898.060
12.000	7.000	78.54	40.06	0.04545	0.02318	0.34000	0.17340	1.28706	0.65640	1287.541	656.646
	2.000	113.10	109.96	0.06545	0.06363	0.48961	0.47601	1.85340	1.80192	1854.098	1802.597
	2.500	113.10	108.19	0.06545	0.06261	0.48961	0.46836	1.85340	1.77296	1854.098	1773.627
	3.000	113.10	106.03	0.06545	0.06136	0.48961	0.45901	1.85340	1.73756	1854.098	1738.220
	3.500	113.10	103.48	0.06545	0.05988	0.48961	0.44796	1.85340	1.69574	1854.098	1696.375
	4.000	113.10	100.53	0.06545	0.05818	0.48961	0.43521	1.85340	1.64747	1854.098	1648.092
	4.500	113.10	97.20	0.06545	0.05625	0.48961	0.42076	1.85340	1.59277	1854.098	1593.371
	5.000	113.10	93.47	0.06545	0.05409	0.48961	0.40461	1.85340	1.53164	1854.098	1532.213
14.000	5.500	113.10	89.34	0.06545	0.05170	0.48961	0.38676	1.85340	1.46407	1854.098	1464.617
	8.500	113.10	56.35	0.06545	0.03261	0.48961	0.24396	1.85340	0.92350	1854.098	923.850
	2.500	153.94	149.03	0.08909	0.08624	0.66641	0.64516	2.52266	2.44221	2523.607	2443.135
	3.000	153.94	146.87	0.08909	0.08500	0.66641	0.63581	2.52266	2.40682	2523.607	2407.728
	3.500	153.94	144.32	0.08909	0.08352	0.66641	0.62476	2.52266	2.36499	2523.607	2365.883
	4.000	153.94	141.37	0.08909	0.08181	0.66641	0.61201	2.52266	2.31673	2523.607	2317.600
	4.500	153.94	138.04	0.08909	0.07988	0.66641	0.59756	2.52266	2.26203	2523.607	2262.880
	5.000	153.94	134.31	0.08909	0.07772	0.66641	0.58141	2.52266	2.20089	2523.607	2201.721
	5.500	153.94	130.18	0.08909	0.07534	0.66641	0.56356	2.52266	2.13332	2523.607	2134.125
	7.000	153.94	115.46	0.08909	0.06681	0.66641	0.49981	2.52266	1.89200	2523.607	1892.711
10.000	153.94	75.40	0.08909	0.04363	0.66641	0.32641	2.52266	1.23560	2523.607	1236.066	

# Heavy Duty Pneumatic and Hydraulic NFPA Steel Cylinders

## AVENTICS CYLINDER APPLICATIONS DATA

### FORCE FOR PUSH & PULL STROKE

BORE	MM ROD DIA.	AREA PUSH	AREA PULL	10 PSI		20 PSI		60 PSI		80 PSI		100 PSI		200 PSI	
				PUSH	PULL	PUSH	PULL	PUSH	PULL	PUSH	PULL	PUSH	PULL	PUSH	PULL
1.500	0.625	1.77	1.46	18	15	35	29	106	88	142	117	177	146	354	293
	1.000	1.77	0.98	18	10	35	20	106	59	142	79	177	98	354	197
2.000	0.625	3.14	2.83	31	28	63	57	188	170	251	227	314	283	628	567
	1.000	3.14	2.35	31	24	63	47	188	141	251	188	314	235	628	471
	1.375	3.14	1.66	31	17	63	33	188	99	251	132	314	166	628	331
2.500	0.625	4.91	4.60	49	46	98	92	295	276	393	368	491	460	982	921
	1.000	4.91	4.12	49	41	98	82	295	247	393	330	491	412	982	825
	1.375	4.91	3.43	49	34	98	69	295	206	393	274	491	343	982	685
	1.750	4.91	2.50	49	25	98	50	295	150	393	200	491	251	982	501
3.250	1.000	8.30	7.51	83	75	166	150	498	451	664	601	830	751	1660	1503
	1.375	8.30	6.82	83	68	166	136	498	409	664	545	830	682	1660	1363
	1.750	8.30	5.89	83	59	166	118	498	354	664	472	830	590	1660	1179
4.000	2.000	8.30	5.16	83	52	166	103	498	310	664	413	830	516	1660	1032
	1.000	12.57	11.78	126	118	251	236	754	707	1006	943	1257	1178	2514	2357
	1.375	12.57	11.09	126	111	251	222	754	665	1006	887	1257	1109	2514	2217
	1.750	12.57	10.16	126	102	251	203	754	610	1006	813	1257	1017	2514	2033
	2.000	12.57	9.43	126	94	251	189	754	566	1006	754	1257	943	2514	1886
5.000	2.500	12.57	7.66	126	77	251	153	754	460	1006	613	1257	766	2514	1532
	1.000	19.64	18.85	196	189	393	377	1178	1131	1571	1508	1964	1885	3928	3771
	1.375	19.64	18.16	196	182	393	363	1178	1089	1571	1452	1964	1816	3928	3631
	1.750	19.64	17.23	196	172	393	345	1178	1034	1571	1379	1964	1724	3928	3447
	2.000	19.64	16.50	196	165	393	330	1178	990	1571	1320	1964	1650	3928	3300
	2.500	19.64	14.73	196	147	393	295	1178	884	1571	1178	1964	1473	3928	2946
	3.000	19.64	12.57	196	126	393	251	1178	754	1571	1006	1964	1257	3928	2514
6.000	3.500	19.64	10.02	196	100	393	200	1178	601	1571	802	1964	1002	3928	2004
	1.375	28.25	26.77	283	268	565	535	1695	1606	2260	2141	2825	2677	5650	5353
	1.750	28.25	25.84	283	258	565	517	1695	1551	2260	2068	2825	2585	5650	5169
	2.000	28.25	25.11	283	251	565	502	1695	1507	2260	2009	2825	2511	5650	5022
	2.500	28.25	23.34	283	233	565	467	1695	1400	2260	1867	2825	2334	5650	4668
	3.000	28.25	21.18	283	212	565	424	1695	1271	2260	1694	2825	2118	5650	4236
	3.500	28.25	18.63	283	186	565	373	1695	1118	2260	1490	2825	1863	5650	3726
7.000	4.000	28.25	15.68	283	157	565	314	1695	941	2260	1255	2825	1568	5650	3137
	3.000	38.49	31.42	385	314	770	628	2309	1885	3079	2514	3849	3142	7698	6284
	3.500	38.49	28.87	385	289	770	577	2309	1732	3079	2310	3849	2887	7698	5774
	4.000	38.49	25.92	385	259	770	518	2309	1555	3079	2074	3849	2592	7698	5185
	5.000	38.49	18.86	385	189	770	377	2309	1131	3079	1508	3849	1886	7698	3771
8.000	1.375	50.27	48.79	503	488	1005	976	3016	2927	4022	3903	5027	4879	10054	9757
	1.750	50.27	47.86	503	479	1005	957	3016	2872	4022	3829	5027	4787	10054	9573
	2.000	50.27	47.13	503	471	1005	943	3016	2828	4022	3770	5027	4713	10054	9426
	2.500	50.27	45.36	503	454	1005	907	3016	2722	4022	3629	5027	4536	10054	9072
	3.000	50.27	43.20	503	432	1005	864	3016	2592	4022	3456	5027	4320	10054	8640
	3.500	50.27	40.65	503	406	1005	813	3016	2439	4022	3252	5027	4065	10054	8130
	4.000	50.27	37.70	503	377	1005	754	3016	2262	4022	3016	5027	3770	10054	7541
	4.500	50.27	34.37	503	344	1005	687	3016	2062	4022	2749	5027	3437	10054	6873
10.000	5.000	50.27	30.64	503	306	1005	613	3016	1838	4022	2451	5027	3064	10054	6127
	5.500	50.27	26.51	503	265	1005	530	3016	1591	4022	2121	5027	2651	10054	5302
	1.750	78.54	76.13	785	761	1571	1523	4712	4568	6283	6091	7854	7614	15708	15227
	2.000	78.54	75.40	785	754	1571	1508	4712	4524	6283	6032	7854	7540	15708	15080
	2.500	78.54	73.63	785	736	1571	1473	4712	4418	6283	5890	7854	7363	15708	14726
	3.000	78.54	71.47	785	715	1571	1429	4712	4288	6283	5718	7854	7147	15708	14294
	3.500	78.54	68.92	785	689	1571	1378	4712	4135	6283	5514	7854	6892	15708	13784
	4.000	78.54	65.97	785	660	1571	1319	4712	3958	6283	5278	7854	6597	15708	13195
	4.500	78.54	62.64	785	626	1571	1253	4712	3758	6283	5011	7854	6264	15708	12527
	5.000	78.54	58.91	785	589	1571	1178	4712	3534	6283	4712	7854	5891	15708	11781
12.000	5.500	78.54	54.78	785	548	1571	1096	4712	3287	6283	4383	7854	5478	15708	10956
	7.000	78.54	40.06	785	401	1571	801	4712	2403	6283	3204	7854	4006	15708	8011
	2.000	113.10	109.96	1131	1100	2262	2199	6786	6598	9048	8797	11310	10996	22620	21992
	2.500	113.10	108.19	1131	1082	2262	2164	6786	6491	9048	8655	11310	10819	22620	21638
	3.000	113.10	106.03	1131	1060	2262	2121	6786	6362	9048	8482	11310	10603	22620	21206
	3.500	113.10	103.48	1131	1035	2262	2070	6786	6209	9048	8278	11310	10348	22620	20696
	4.000	113.10	100.53	1131	1005	2262	2011	6786	6032	9048	8043	11310	10053	22620	20107
	4.500	113.10	97.20	1131	972	2262	1944	6786	5832	9048	7776	11310	9720	22620	19439
	5.000	113.10	93.47	1131	935	2262	1869	6786	5608	9048	7477	11310	9347	22620	18693
	5.500	113.10	89.34	1131	893	2262	1787	6786	5361	9048	7147	11310	8934	22620	17868
14.000	8.500	113.10	56.35	1131	564	2262	1127	6786	3381	9048	4508	11310	5636	22620	11271
	2.500	153.94	149.03	1539	1490	3079	2981	9236	8942	12315	11922	15394	14903	30788	29806
	3.000	153.94	146.87	1539	1469	3079	2937	9236	8812	12315	11750	15394	14687	30788	29374
	3.500	153.94	144.32	1539	1443	3079	2886	9236	8659	12315	11546	15394	14432	30788	28864
	4.000	153.94	141.37	1539	1414	3079	2827	9236	8482	12315	11310	15394	14137	30788	28275
	4.500	153.94	138.04	1539	1380	3079	2761	9236	8282	12315	11043	15394	13804	30788	27607
	5.000	153.94	134.31	1539	1343	3079	2686	9236	8058	12315	10744	15394	13431	30788	26861
	5.500	153.94	130.18	1539	1302	3079	2604	9236	7811	12315	10415	15394	13018	30788	26036
7.000	153.94	115.46	1539	1155	3079	2309	9236	6927	12315	9236	15394	11546	30788	23091	
10.000	153.94	75.40	1539	754	3079	1508	9236	4524	12315	6032	15394	7540	30788	15080	

# Heavy Duty Pneumatic and Hydraulic NFPA Steel Cylinders

## AVENTICS CYLINDER APPLICATIONS DATA

### FORCE FOR PUSH & PULL STROKE

BORE	MM ROD DIA.	250 PSI		500 PSI		1000 PSI		1500 PSI		2000 PSI		2500 PSI		3000 PSI	
		PUSH	PULL	PUSH	PULL	PUSH	PULL	PUSH	PULL	PUSH	PULL	PUSH	PULL	PUSH	PULL
1.500	0.625	443	366	885	732	1770	1463	2655	2195	3540	2926	4425	3658	5310	4390
	1.000	443	246	885	492	1770	985	2655	1477	3540	1969	4425	2462	5310	2954
2.000	0.625	785	708	1570	1417	3140	2833	4710	4250	6280	5666	7850	7083	9420	8500
	1.000	785	589	1570	1177	3140	2355	4710	3532	6280	4709	7850	5887	9420	7064
	1.375	785	414	1570	828	3140	1655	4710	2483	6280	3310	7850	4138	9420	4965
2.500	0.625	1228	1151	2455	2302	4910	4603	7365	6905	9820	9206	12275	11508	14730	13810
	1.000	1228	1031	2455	2062	4910	4125	7365	6187	9820	8249	12275	10312	14730	12374
	1.375	1228	856	2455	1713	4910	3425	7365	5138	9820	6850	12275	8563	14730	10275
	1.750	1228	626	2455	1253	4910	2505	7365	3758	9820	5010	12275	6263	14730	7515
3.250	1.000	2075	1879	4150	3757	8300	7515	12450	11272	16600	15029	20750	18787	24900	22544
	1.375	2075	1704	4150	3408	8300	6815	12450	10223	16600	13630	20750	17038	24900	20445
	1.750	2075	1474	4150	2948	8300	5895	12450	8843	16600	11790	20750	14738	24900	17685
	2.000	2075	1290	4150	2579	8300	5158	12450	7738	16600	10317	20750	12896	24900	15475
4.000	1.000	3143	2946	6285	5892	12570	11785	18855	17677	25140	23569	31425	29462	37710	35354
	1.375	3143	2771	6285	5543	12570	11085	18855	16628	25140	22170	31425	27713	37710	33255
	1.750	3143	2541	6285	5083	12570	10165	18855	15248	25140	20330	31425	25413	37710	30495
	2.000	3143	2357	6285	4714	12570	9428	18855	14143	25140	18857	31425	23571	37710	28285
	2.500	3143	1915	6285	3831	12570	7661	18855	11492	25140	15322	31425	19153	37710	22983
5.000	1.000	4910	4714	9820	9427	19640	18855	29460	28282	39280	37709	49100	47137	58920	56564
	1.375	4910	4539	9820	9078	19640	18155	29460	27233	39280	36310	49100	45388	58920	54465
	1.750	4910	4309	9820	8618	19640	17235	29460	25853	39280	34470	49100	43088	58920	51705
	2.000	4910	4125	9820	8249	19640	16498	29460	24748	39280	32997	49100	41246	58920	49495
	2.500	4910	3683	9820	7366	19640	14731	29460	22097	39280	29462	49100	36828	58920	44193
	3.000	4910	3143	9820	6286	19640	12571	29460	18857	39280	25142	49100	31428	58920	37713
	3.500	4910	2505	9820	5010	19640	10019	29460	15029	39280	20038	49100	25048	58920	30057
6.000	1.375	7063	6691	14125	13383	28250	26765	42375	40148	56500	53530	70625	66913	84750	80295
	1.750	7063	6461	14125	12923	28250	25845	42375	38768	56500	51690	70625	64613	84750	77535
	2.000	7063	6277	14125	12554	28250	25108	42375	37663	56500	50217	70625	62771	84750	75325
	2.500	7063	5835	14125	11671	28250	23341	42375	35012	56500	46682	70625	58353	84750	70023
	3.000	7063	5295	14125	10591	28250	21181	42375	31772	56500	42362	70625	52953	84750	63543
	3.500	7063	4657	14125	9315	28250	18629	42375	27944	56500	37258	70625	46573	84750	55887
	4.000	7063	3921	14125	7842	28250	15684	42375	23526	56500	31368	70625	39210	84750	47052
7.000	3.000	9623	7855	19245	15711	38490	31421	57735	47132	76980	62842	96225	78553	115470	94263
	3.500	9623	7217	19245	14435	38490	28869	57735	43304	76980	57738	96225	72173	115470	86607
	4.000	9623	6481	19245	12962	38490	25924	57735	38886	76980	51848	96225	64810	115470	77772
	5.000	9623	4714	19245	9428	38490	18855	57735	28283	76980	37710	96225	47138	115470	56565
8.000	1.375	12568	12196	25135	24393	50270	48785	75405	73178	100540	97570	125675	121963	150810	146355
	1.750	12568	11966	25135	23933	50270	47865	75405	71798	100540	95730	125675	119663	150810	143595
	2.000	12568	11782	25135	23564	50270	47128	75405	70693	100540	94257	125675	117821	150810	141385
	2.500	12568	11340	25135	22681	50270	45361	75405	68042	100540	90722	125675	113403	150810	136083
	3.000	12568	10800	25135	21601	50270	43201	75405	64802	100540	86402	125675	108003	150810	129603
	3.500	12568	10162	25135	20325	50270	40649	75405	60974	100540	81298	125675	101623	150810	121947
	4.000	12568	9426	25135	18852	50270	37704	75405	56556	100540	75408	125675	94260	150810	113112
	4.500	12568	8592	25135	17183	50270	34366	75405	51549	100540	68732	125675	85915	150810	103098
10.000	5.000	12568	7659	25135	15318	50270	30635	75405	45953	100540	61270	125675	76588	150810	91905
	5.500	12568	6628	25135	13256	50270	26512	75405	39768	100540	53024	125675	66280	150810	79536
	1.750	19635	19034	39270	38068	78540	76135	117810	114203	157080	152270	196350	190338	235620	228405
	2.000	19635	18850	39270	37699	78540	75398	117810	113098	157080	150797	196350	188496	235620	226195
	2.500	19635	18408	39270	36816	78540	73631	117810	110447	157080	147262	196350	184078	235620	220893
	3.000	19635	17868	39270	35736	78540	71471	117810	107207	157080	142942	196350	178678	235620	214413
	3.500	19635	17230	39270	34460	78540	68919	117810	103379	157080	137838	196350	172298	235620	206757
	4.000	19635	16494	39270	32987	78540	65974	117810	98961	157080	131948	196350	164935	235620	197922
	4.500	19635	15659	39270	31318	78540	62636	117810	93954	157080	125272	196350	156590	235620	187908
	5.000	19635	14726	39270	29453	78540	58905	117810	88358	157080	117810	196350	147263	235620	176715
12.000	5.500	19635	13696	39270	27391	78540	54782	117810	82173	157080	109564	196350	136955	235620	164346
	7.000	19635	10014	39270	20028	78540	40055	117810	60083	157080	80110	196350	100138	235620	120165
	2.000	28275	27490	56550	54979	113100	109958	169650	164938	226200	219917	282750	274896	339300	329875
	2.500	28275	27048	56550	54096	113100	108191	169650	162287	226200	216382	282750	270478	339300	324573
	3.000	28275	26508	56550	53016	113100	106031	169650	159047	226200	212062	282750	265078	339300	318093
	3.500	28275	25870	56550	51740	113100	103479	169650	155219	226200	206958	282750	258698	339300	310437
	4.000	28275	25134	56550	50267	113100	100534	169650	150801	226200	201068	282750	251335	339300	301602
	4.500	28275	24299	56550	48598	113100	97196	169650	145794	226200	194392	282750	242990	339300	291588
5.000	28275	23366	56550	46733	113100	93465	169650	140198	226200	186930	282750	233663	339300	280395	
14.000	5.500	28275	22336	56550	44671	113100	89342	169650	134013	226200	178684	282750	223355	339300	268026
	8.500	28275	14089	56550	28178	113100	56355	169650	84533	226200	112710	282750	140888	339300	169065
	2.500	38485	37258	76970	74516	153940	149031	230910	223547	307880	298062	384850	372578	461820	447093
	3.000	38485	36718	76970	73436	153940	146871	230910	220307	307880	293742	384850	367178	461820	440613
	3.500	38485	36080	76970	72160	153940	144319	230910	216479	307880	288638	384850	360798	461820	432957
	4.000	38485	35344	76970	70687	153940	141374	2							

# Heavy Duty Pneumatic and Hydraulic NFPA Steel Cylinders

## AVENTICS CYLINDER APPLICATIONS DATA

### MOUNTING CONSIDERATIONS FOR CYLINDERS

Selection of mounting style depends primarily upon the operating specifications of the application. Mountings are generally one of the following three types:

#### 1. FIXED CENTERLINE MOUNTINGS

Where the thrust of the cylinder is focused on the centerline of the cylinder rod.

#### 2. FIXED NON-CENTERLINE MOUNTINGS

Where the thrust of the cylinder is aligned parallel to, but not on, the centerline of the cylinder rod.

#### 3. PIVOTED CENTERLINE MOUNTINGS

Where the centerline of the cylinder may swing in one or more directions. Usually major movement is in one plane.

A very important general consideration is to keep the cylinder thrust as close as possible to the centerline of the piston rod and free from misalignment or side thrust. Off-center thrust or side loads subtract substantially from the anticipated rod bearing and rod seal service life.

Off-center thrust and side loading can be caused by cylinder deflection under load, machine frame deflection, rod bending or sagging, cylinder pivot binding, non-linear load movement, shifting of load; some of which are shown below:

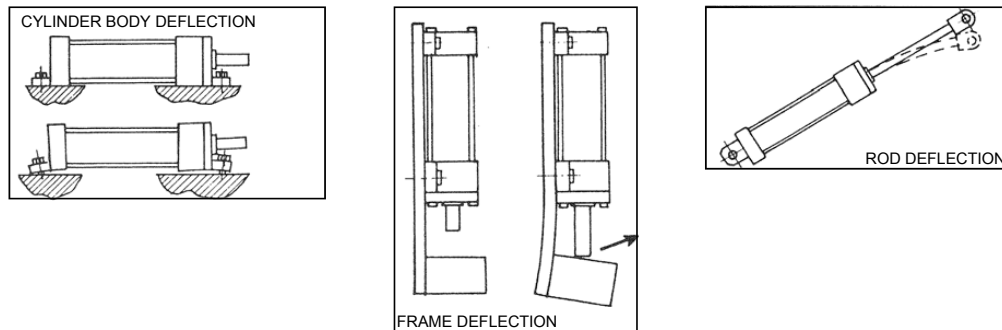

In addition to the mounting styles, several other factors should be considered when mounting a cylinder. Care should be taken to avoid painting or damaging the exposed portion of the piston rod during construction. Threaded pieces should be pulled tight against thread shoulders to minimize bending and reduce fatigue stress. Rotation of the piston rod within the cylinder should be avoided to prevent possible scoring of the cylinder tube and damage to the piston seals. Long cylinders may require additional body support to prevent damaging sag.

Major consideration must be given to the factors which might cause premature failure of the cylinder: unusual acceleration, unusual deceleration, alignment, support of cylinder weight, linear or curvilinear travel path of the load being moved, jackknifing of the cylinder, and the column strength of the rod. Some mounting styles are more suited than others to each of the above application factors.

# Heavy Duty Pneumatic and Hydraulic NFPA Steel Cylinders

## AVENTICS CYLINDER APPLICATIONS DATA

### MOUNTING CONSIDERATIONS FOR CYLINDERS

#### FIXED CENTERLINE MOUNTINGS

These mounting styles, illustrated below, tend to be more stable against sway on the power extension stroke. Rigid machine frame members are required to prevent misalignment under loads. The travel path of the rod end should be linear and be guided if at all possible. Long supported extension of the rod end must be avoided. Refer to the stop lube calculation data which shows the advantages of supporting and using reliable guiding on the rod end. Long stroke cylinders with fixed end mounts may require additional support at the free end of the cylinder body. This is illustrated in dotted outlines in the sketches below.

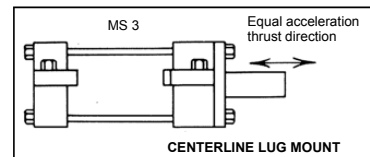
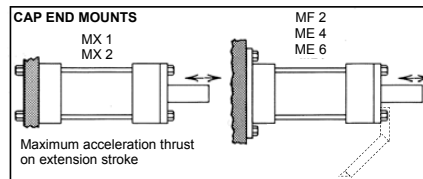
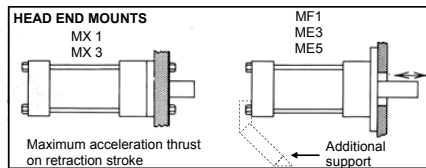

#### FIXED NON-CENTERLINE MOUNTINGS

These types of mountings are perhaps the easiest to use for mounting and replacement ease. The offset thrust line introduces bending stresses and additional loads on the mounting bolts. This type should be very well aligned for maximum service life. The load must travel in a very linear path and be supported and guided both horizontally and vertically as the data for calculating stop tube and column strength illustrates.

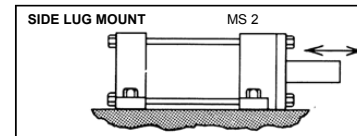
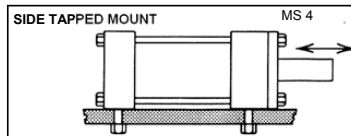
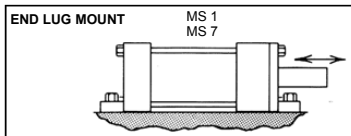

When applying these mounts with offset thrust under high pressures or shock loads, properly located shear pins or keys can be used. These provide positive location and prevent slight movement of the cylinder under shock conditions, which the normal clearance in the mounting bolt holes would allow. Very close tolerances (.001") should be maintained between keys and keyways. Keys should be located as illustrated above, at one end of the cylinder ONLY and extend all the way across the end of the cylinder. When using dowel pins, DO NOT pin across opposite corners, as serious twisting stresses will result.

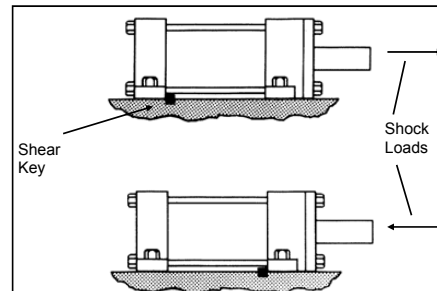

# Heavy Duty Pneumatic and Hydraulic NFPA Steel Cylinders

## AVENTICS CYLINDER APPLICATIONS DATA

### MOUNTING CONSIDERATIONS FOR CYLINDERS

#### FIXED NON-CENTERLINE MOUNTINGS (continued)

Fixed mount cylinders can tolerate a slight misalignment that is ZERO at full retraction and increases slightly with stroke. With other than very large rods, a misalignment of about .003" to .005" per foot of stroke is usually permissible. Rigid mounted cylinders cannot tolerate a fixed misalignment, particularly at full retraction.

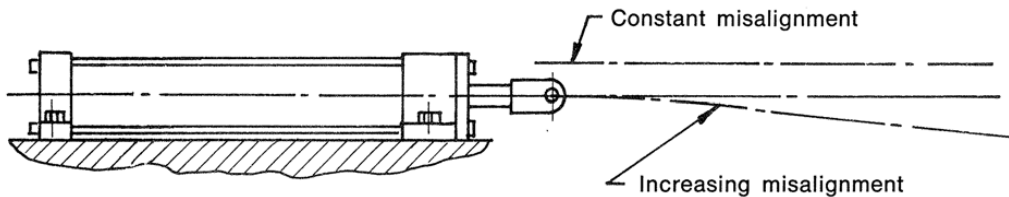

#### PIVOTED CENTERLINE MOUNTINGS

If the path of the load is curved or misalignment is a problem, a pivoted centerline mounting should be used. This compensation of non-linear travel is in ONE PLANE ONLY, as would occur during the operation of a lever. Pivot mounts require the rod end attachment to also be a pivot type. Close tolerance pins should be used and it is recommended that the cylinder manufacturer's accessory brackets be used to maintain good fits.

For short strokes, medium or smaller bore cylinder applications, the clevis mount is recommended. This is probably the most widely used cylinder mounting. Where the clevis mount would normally be used, but would cause the overall length of the cylinder to be excessive, the cap trunnion mount can be used. Head end trunnions should be carefully applied to either short strokes or to application where the weight of the cylinder falls vertically below the pin.

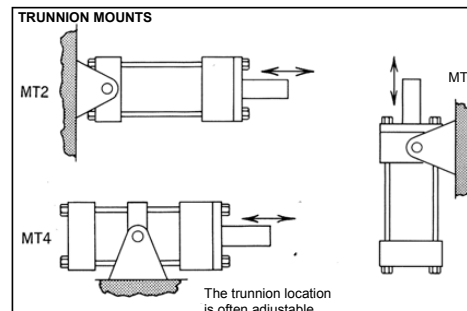
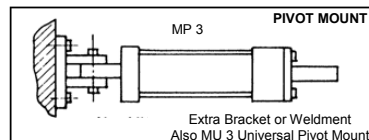
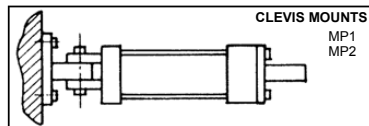

For long stroke cylinders and/or heavy cylinders, the center or intermediate trunnion mount is recommended. This mount supports the weight of the cylinder and should be located near the balance point of the cylinder at the time of maximum thrust. For general applications, a good estimate for the location of the intermediate trunnion is 1/3 back from the head end.

The MU3 (Universal) type mount is a pivot mount MP3 with a spherical bearing fitted into the pivot to permit 5 to 10 degrees of movement in a plane perpendicular to the major place of pivot movement. It is probably the most serviceable of the pivoted centerline mounts. For maximum effectiveness, a spherical bearing type rod end fitting should be utilized at the same time.



# Heavy Duty Pneumatic and Hydraulic NFPA Steel Cylinders

## AVENTICS CYLINDER APPLICATIONS DATA

### STOP TUBE & COLUMN STRENGTH CONSIDERATIONS

#### STOP TUBE (see page 68)

In long cylinders which are pushing a load, internal stop tubes are used to prevent excessive bearing wear and jackknifing of the cylinder. They are installed between the piston and the head, providing additional bearing support by increasing the distance between the piston and the head in the fully extended position. Actual stop tubes may take the form of a spacer on the rod on a dual piston type design which allows the utilization of standard cushioning arrangements.

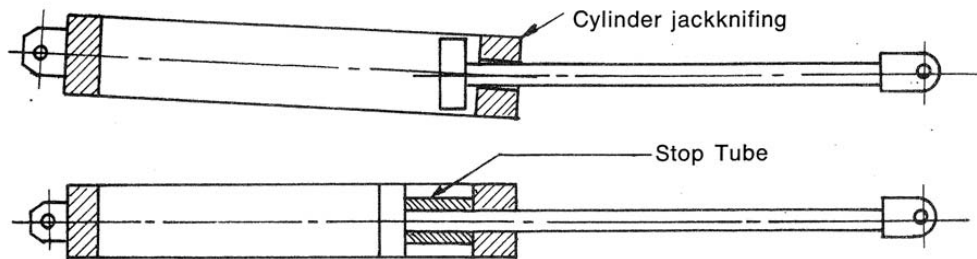

For long, trouble free bearing service, the bearing loads should not exceed about 200 psi. Standard cylinders are not designed for heavy eccentric loads.

The use of oversize rods to reduce bearing loads is not recommended. They are not as effective as stop tubes, and if misalignment occurs the additional rod stiffness will actually increase bearing loads. For long push stroke cylinders, a stop tube may be required to limit radial bearing loads to a safe value and prevent jackknifing. They are especially desirable in long stroke pivoted centerline style mountings. The effect of a stop tube may be duplicated by providing additional unused stroke and stopping the cylinder extension by external means.

#### COLUMN STRENGTH & OVERSIZE RODS (see page 69)

Standard size rods are recommended for use in cylinder applications where column strength, rod sag, or rate of cylinder return do not require an oversize rod. Being more flexible, standard rods absorb shock loads and minimize bearing loads caused by misalignments. For long push stroke cylinders, an oversize rod may be required to prevent column failure and rod bending. Total cylinder length, extended is considered in column strength. Refer to the tables on the following pages for calculations regarding the column strength and stop tube required for a cylinder application.

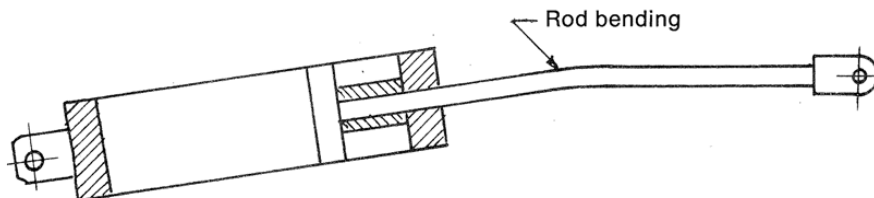

# Heavy Duty Pneumatic and Hydraulic NFPA Steel Cylinders

## AVENTICS CYLINDER APPLICATIONS DATA

### STOP TUBE

#### To determine whether a stop is required on push stroke cylinders:

STEP 1— Determine which example below corresponds to your application.

STEP 2— Determine the value of "L" from the instructions given. Then find "L" dimension in the table at the right for the required stop tube length. (Specify the **effective stroke** plus the **stop tube length** when ordering).

STEP 3— Add stop tube length to **original "L"** dimension to obtain your **Adjusted "L"** dimension.  
Example: "L" = 96", therefore, Stop Tube = 6". Therefore **Adjusted L=102"** (96+6)

STEP 4— Use **Adjusted "L"** to figure rod column strength at maximum pressure rating of the cylinder, page 68

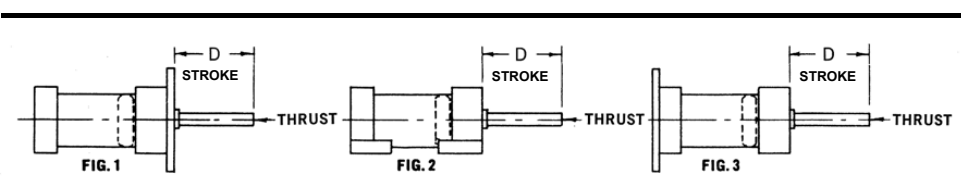

Typical rigidly mounted cylinders with rod **unsupported at free end**. May be mounted either horizontally or vertically. Use the equation  $L = 4D$  to determine values of "L" for all cylinder mountings in this category.

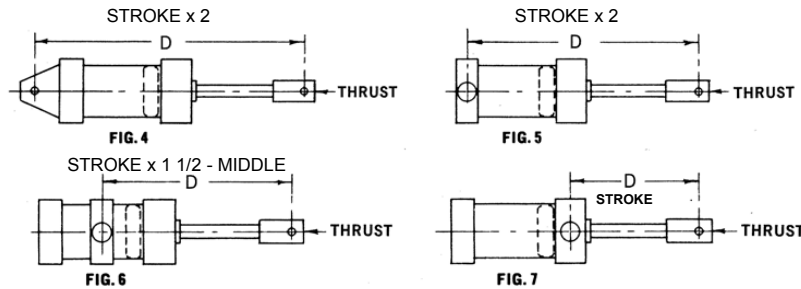

Typical trunnion mounted cylinders may be mounted either horizontally or vertically. Use the equation  $L=D$  to determine values of "L" for all cylinder mountings in this category. For center trunnion mounted cylinders (Figure 6), the position of the trunnion for most favorable bearing loads is obtained when "D" dimension with the rod retracted is approximately 1/3 overall length of cylinder with rod retracted.

Typical rigidly mounted cylinder with free end of rod **supported with short guide**. May be mounted either horizontally or vertically. Use the equation  $L=D$  to determine values of "L" for all cylinder mountings in this category.

Typical rigidly mounted cylinder with free end of rod **supported with long closely-fitting guide**. May be mounted either horizontally or vertically. Use the equation  $L=1/2 D$  to determine values of "L" for all cylinder mountings in this category.

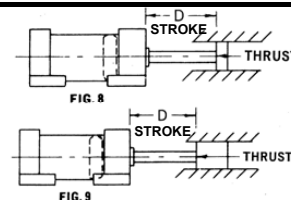

#### TANDEM AND DUPLEX CYLINDERS (Available in POWERMASTER® & PRESSUREMASTER®)

Please contact factory for dimensions, pricing and delivery.  
**Tandem cylinders** allow increased output force and are made of two cylinders of inline mounting with pistons connected by a common piston rod and rod seals. Rod seals are installed between the cylinders to permit double acting operation of each.



**Duplex cylinders** are made for three-position operation by joining two cylinders end to end without connecting the pistons with rod seals between them for double action operation. Below left is a back-to-back configuration; at right is an inline application.



"L" (INCHES)	STOP TUBE LENGTH (INCHES)
0-40	0
41-50	1
51-60	2
61-70	3
71-80	4
81-90	5
91-100	6
101-110	7
111-120	8
121-130	9
131-140	10
141-150	11
151-160	12
161-170	13
171-180	14
181-190	15
191-200	16
201-210	17
211-220	18
221-230	19
231-240	20
241-250	21
251-260	22
261-270	23
271-280	24
281-290	25
291-300	26
301-310	27

# Heavy Duty Pneumatic and Hydraulic NFPA Steel Cylinders

## AVENTICS CYLINDER APPLICATIONS DATA

### COLUMN STRENGTH & OVERSIZE ROD SELECTION

Based on 100,000 psi tensile strength rod material

Standard rod diameters are recommended for all PULL STROKE applications. To determine the correct rod diameter required for PUSH STROKE application, follow these simple steps:

STEP 1— Determine the value of “L” from the illustration shown on page 67.  
(Use Adjusted “L” dimension for cylinder with Stop Tube).

STEP 2— For your cylinder size and maximum operating pressure, determine your PUSH STROKE THRUST from the Thrust Chart on page 62 and 63.

STEP 3— Find your thrust in the left hand column and locate your “L” dimension (or Adjusted “L”

dimension in the same horizontal line to the right; (if your exact “L” or adjusted “L” dimension is not shown, move to the right in the same horizontal column to the next larger number). Read vertically up from this number to the rod diameter shown. This is the required rod diameter for your application.

EXAMPLE: Adjusted L of 80” at 16,000 # would require 2-1/2” rod in the cylinder.

T H R U S T  I N  P O U N D S  A T  E N D  O F  R O D	Thrust *T IN POUNDS	ROD DIAMETERS														
		5/8	1	1-3/8	1-3/4	2	2-1/2	3	3-1/2	4	4-1/2	5	5-1/2	7	8-1/2	10
	50	67														
	100	58	110													
	150	53	103													
	250	43	94	146												
	400	37	83	134	186											
	700	30	68	118	168	202	275									
	1,000	27	60	105	155	190	257	330								
	1,400	24	53	92	142	174	244	308	385							
	1,800	22	48	82	127	160	230	296	366	440						
	2,400	19	45	75	114	145	213	281	347	415	488					
	3,200	16	41	67	103	130	194	261	329	400	461					
	4,000	13	38	63	94	119	175	240	310	378	446					
	5,000	9	34	60	87	110	163	225	289	360	426	494				
	6,000		30	56	82	102	152	208	274	342	410	476				
	8,000		26	50	76	93	137	188	245	310	375	447				
	10,000		21	45	70	89	125	172	222	279	349	412	482			
	12,000		17	41	65	84	118	152	210	269	326	388	454			
	16,000			34	57	75	110	142	188	235	292	350	420			
	20,000			28	52	68	103	136	172	218	270	326	385			
	30,000				39	55	87	120	156	189	230	285	330			
	40,000				22	43	74	108	142	177	210	248	294			
	50,000					30	66	96	130	165	200	234	269	408		
	60,000						57	88	119	154	190	225	256	384		
	80,000						36	71	104	137	170	204	240	348		
	100,000							57	90	120	154	199	222	324	435	605
	120,000							45	77	108	146	175	207	313	396	551
	140,000								64	98	128	160	194	301	365	510
	160,000								47	86	118	148	182	279	345	476
	200,000									67	98	131	161	260	306	428
	250,000										72	109	141	236	275	380
	300,000											86	120	212	251	350
	350,000											52	100	195	234	324
	400,000												77	182	216	301
	500,000													152	194	269

# Heavy Duty Pneumatic and Hydraulic NFPA Steel Cylinders

## AVENTICS CYLINDER APPLICATIONS DATA

### CYLINDER SPECIFICATION SHEET

Customer: \_\_\_\_\_ Cylinder Location / Machine: \_\_\_\_\_

PLEASE CIRCLE EACH ITEM & FILL IN THE APPROPRIATE BLANKS

1. QUANTITY	_____	PRICING
2. BASIC CYL.	MODEL: HHT PPT PHT TM BORE DIA.: 1-1/2 2 2-1/2 3-1/4 4 5 6 7 8 10 12-14 ROD DIA.: 5/8, 1, 1-3/8, 1-3/4, 2, 2-1/2, 3, 3-1/2, 4, 4-1/2, 5, 5-1/2, 7, 8- STD.MOUNTING: MP-1, MP-2, MP-3, MP-4, MU-3, MF-1, MF-2, MF-5, MF-6, ME-3, ME-4, ME-5, ME-6, MS-1, MS-2, MS-3, MS-4, MS-7, MT-1, MT-2, MT-4, X1= _____, MX-0, MX-1, MX-2, MX-3, MX-4 TIE ROD BB = ROD: Single Double Special Mounting _____	
3. STROKE	* STROKE _____ Inches @ _____ Per inch FOR STOP TUBES SPECIFY: Length: _____ Effective Working Stroke Base Price _____ * Plus _____ Inches @ _____ Per inch	
4. ROD	Rod End Style: Male Female Threads SPECIAL ROD END MODIFICATIONS: Specify with NFPA dimensions _____ SPECIAL ROD MATERIAL _____ Base Price _____ * Plus _____ Inches @ _____ Per inch	
5. CUSHION	Head End: YES NO Head End Adj. Location 1 2 3 4 Cap End: YES NO Cap End Adj. Location 1 2 3 4 SPECIAL CUSHION MODIFICATIONS: Specify Extended, Etc. _____	
6. PORTS	Std. Ports: YES NO Locations: Head End 1 2 3 4 Cap End 1 2 3 EXTRA or SPECIAL Head End: Qty _____ Type _____ Size _____ Location 1 2 3 Cap End: Qty _____ Type _____ Size _____ Location 1 2 3	
7. BLEEDS	Head End _____ Location 1 2 3 4 Cap End _____ Location 1 2 3	
8. SEALS	Standard Viton Cast-Iron Poly-Pak Special _____	
9. OPERATING CONDITIONS	Air _____ Oil _____ Water _____ Other _____ Hydraulic Fluid _____ Temperature _____ Pressure (operating) _____ Pressure (max) _____ Water Fitted _____ Other _____	
10. SPECIAL FEATURES	_____ _____	

Cylinder Part No. \_\_\_\_\_ **TOTAL LIST PRICE**

ACCESSORIES REQUIRED (specify Part Number and Quantity)

	QTY	PART NUMBER	@ _____
Rod Clevis	_____	_____	_____
Pin	_____	_____	_____
Female Rod Eye	_____	_____	_____
Clevis Bracket	_____	_____	_____
Eye Bracket	_____	_____	_____
Other Accessory	_____	_____	_____

**\* NOTE: Fraction of inch priced at next whole inch increment.**

**TOTAL LIST PRICE CYLINDER & ACCESSORIES**

# Heavy Duty Pneumatic and Hydraulic NFPA Steel Cylinders

## POWERMASTER® PPT PNEUMATIC & PHT HYDRAULIC CYLINDERS

### CYLINDER OPTIONS OVERSIZE PORTS OFFERED IN WELDED BOSS—HEAD ONLY

EMERSON OFFERS OPTIONAL CYLINDER PORT CONNECTIONS TO MEET SPECIAL SERVICE AND/OR APPLICATION REQUIREMENTS.

1. SAE straight thread ports are offered as an option at no extra charge
2. Oversize ports are located in welded bosses as shown. These ports can be located in any position offered with standard ports. Large rods limit SAE port sizes.
3. Oversize ports do not necessarily mean increased flow capacity; consult factory

BORE	EE			A	B	C	D	P	OVERSIZE PORT		
	NPTF	SAE	DASH						NPTF	SAE	DASH
1.5	3/8	9/16-18	-6	1-1/8	15/16	9/16	1/2	2-1/4	1/2*	3/4-16*	-8
2	3/8	9/16-18	-6	1-1/8	15/16	9/16	1/2	2-1/4	1/2*	3/4-16*	-8
2.5	3/8	9/16-18	-6	1-1/8	15/16	9/16	1/2	2-3/8	1/2*	3/4-16*	-8
3.25	1/2	3/4-16	-8	1-3/8	1	11/16	5/8	2-5/8	3/4*	1-1/16-12*	-12
4	1/2	3/4-16	-8	1-3/8	1	11/16	5/8	2-5/8	3/4*	1-1/16-12*	-12
5	1/2	3/4-16	-8	1-3/8	1	11/16	5/8	2-7/8	3/4*	1-1/16-12*	-12
6	3/4	1-1/16-12	-12	1-3/4	1-3/16	15/16	3/4	3-1/8	1*	1-5/16-12*	-16
8	3/4	1-1/16-12	-12	1-3/4	1-3/16	15/16	3/4	3-1/4	1	1-5/16-12*	-16

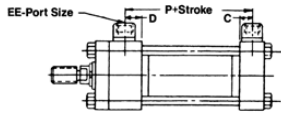
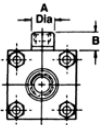

\*Available on head end only. No oversize ports offered on cap on standard cylinders, except 8" bore. When cap oversize ports are required, the catalog "LB" dimension becomes equal to the "LD" catalog dimension due to the required increase in cap thickness ("J" dimension).

### ROD PROTECTIVE COVER

Emerson offers a standard rod protective cover option on Powermaster cylinders. This option provides a dirt and oil resistant cover to extend piston rod and seal service life in applications where severe environmental conditions exist. The standard cover material is nylon fabric neoprene coated and is suitable for operation in ambient temperatures between -45° and +220°F. Rod covers are also available for larger rod sizes on special request.

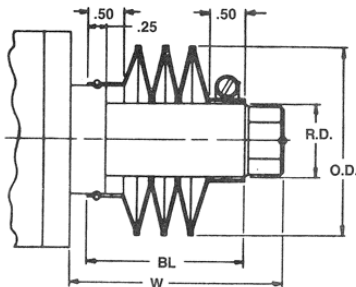

PISTON ROD		COVER OD	LENGTH FACTOR LF
CODE	DIAMETER		
D	.63"	2.25	.13
F	1.00"	2.62	.13
G	1.38"	3.00	.13
H	1.75"	3.38	.13
J	2.00"	3.75	.13
K	2.50"	4.38	.13
L	3.00"	5.12	.10

Determine the extra piston rod extension (ERE) required to accommodate the rod cover.

$$ERE = (\text{cylinder stroke} \times \text{length factor LF}) + .75"$$

(see table above for LF)

Adjust cylinder catalog dimension V, WF, etc. as required to insure correct installation dimensions.

$$BL = ERE + .25$$

$$W = ERE + W \text{ (from dimension charts)}$$

NOTE: these calculations are needed for cylinder application, but not for pricing.

### STROKE ADJUSTMENT

Emerson offers a standard arrangement to provide cylinder stroke adjustment. When an application requires a precise cylinder stroke or when infrequent stroke length adjustment is required, this retracted position stroke adjustment should be specified. The length of the stroke adjustment must be specified when ordered. Cushioning is not available on the cap end when this standard stroke adjuster is utilized. Where cushioning is required, other designs are available.

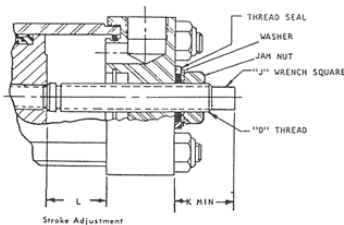

BORE SIZE	D	J	K	L MAX.
1.50"	1/2-20	.31	.94	5.00
2.00"	1/2-20	.31	.94	5.00
2.50"	3/4-16	.44	1.25	8.00
3.25"	3/4-16	.44	1.25	8.00
4.00"	3/4-16	.44	1.25	8.00
5.00"	1-14	.62	1.69	9.00
6.00"	1-14	.62	1.69	9.00
8.00"	1-1/2-12	.94	2.12	18.00

# Heavy Duty Pneumatic and Hydraulic NFPA Steel Cylinders

## POWERMASTER® PPT PNEUMATIC & PHT HYDRAULIC CYLINDERS and PRESSUREMASTER® HHT HYDRAULIC CYLINDERS

### ROD END AND PORT DIMENSIONS

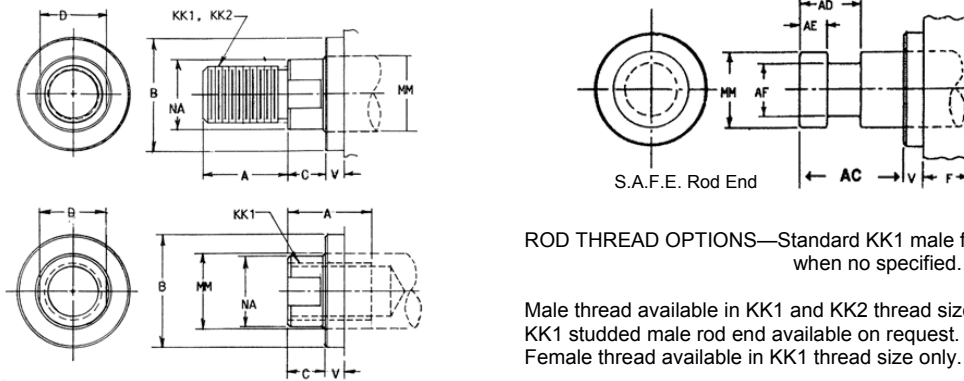

ROD THREAD OPTIONS—Standard KK1 male furnished when no specified.

Male thread available in KK1 and KK2 thread sizes.  
KK1 studded male rod end available on request.  
Female thread available in KK1 thread size only.

### PISTON ROD END

MM Rod Dia.	A	B +0.000 -0.003	C	D	AC	AD	AE +0.000 -0.005	AF	KK1	KK2	NA +0.002 -0.002
0.625	0.750	1.024	0.38	0.50	1.12	0.62	0.250	0.375	7/16-20	1/2-20	0.563
1.000	1.125	1.499	0.50	0.88	1.62	0.94	0.375	0.688	3/4-16	7/8-14	0.938
1.375	1.625	1.999	0.62	1.12	1.75	1.06	0.375	0.875	1-14	1 1/4-12	1.313
1.750	2.000	2.374	0.75	1.50	2.00	1.31	0.500	1.125	1 1/4-12	1 1/2-12	1.688
2.000	2.250	2.624	0.88	1.69	2.62	1.69	0.625	1.380	1 1/2-12	1 3/4-12	1.940
2.500	3.000	3.124	1.00	2.06	3.25	1.94	0.750	1.750	1 7/8-12	2 1/4-12	2.438
3.000	3.500	3.749	1.00	2.62	3.62	2.44	0.875	2.250	2 1/4-12	2 3/4-12	2.938
3.500	3.500	4.249	1.00	3.00	4.38	2.69	1.000	2.500	2 1/2-12	3-12	3.438
4.000	4.000	4.749	1.00	3.38	4.50	2.69	1.000	3.000	3-12	3 1/2-12	3.938
4.500	4.500	5.249	1.00	SH 1	5.25	3.19	1.500	3.500	3 1/4-12	4 1/4-12	4.438
5.000	5.000	5.749	1.00	SH 1	5.38	3.19	1.500	3.875	3 1/2-12	4 3/4-12	4.938
5.500	5.500	6.246	1.00	SH 1	6.25	3.94	1.875	4.375	4-12	5 1/4-12	5.438
7.000	7.000	7.749	1.00	SH 2					5 1/2-12	6-12	6.938
8.000	8.000	8.749	1.00	SH 2					5 3/4-12	7 1/2-12	7.938
10.000	10.000	10.749	1.00	SH 2					7 1/4-12	9 1/2-12	9.875

Spanner Wrench Holes: SH 1 = 0.56" dia., SH 2 = 0.66" dia.

METRIC ROD THREADS AVAILABLE AS AN OPTION. TO FIND AVAILABLE PORTING OPTIONS, SEE PAGE 9

### SAE STRAIGHT THREAD O-RINGS BOSS

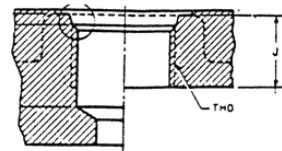

### NPTF PIPE THREADS

NOM. SIZE	THDS PER IN.	PIPE OD	EFF. THD. DEPTH
3/8	18	0.68	0.41
1/2	14	0.84	0.54
3/4	14	1.05	0.55
1	11-1/2	1.32	0.68
1-1/4	11-1/2	1.66	0.71
1-1/2	11-1/2	1.90	0.72
2	11-1/2	2.38	0.76
2-1/2	8	2.88	1.14

EQUIV. NPTF	SAE THREAD SIZE	NOMINAL TUBING		THREAD DEPTH J
		SIZE	DASH	
3/8	9/16-18	3/8	-6	.50
1/2	3/4-16	1/2	-8	.56
1/2	7/8-14	5/8	-10	.65
3/4	1-1/16-12	3/4	-12	.75
3/4	1-3/16-12	7/8	-14	.75
1	1-5/16-12	1	-16	.75
1-1/4	1-5/8-12	1-1/4	-20	.75
1-1/2	1-7/8-12	1-1/2	-24	.75
2	2-1/2-12	2	-32	.75



# Heavy Duty Pneumatic and Hydraulic NFPA Steel Cylinders

## AVENTICS ACCESSORIES

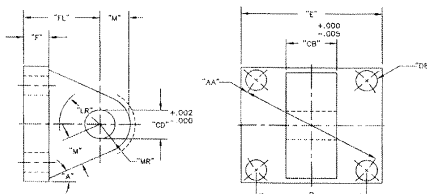
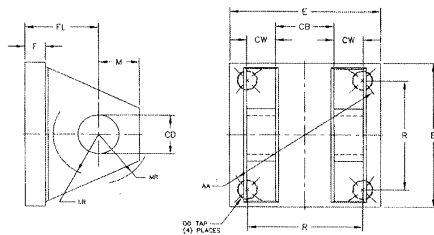
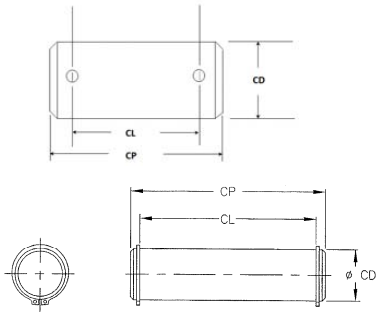
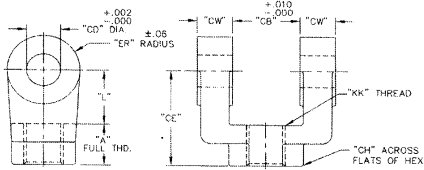
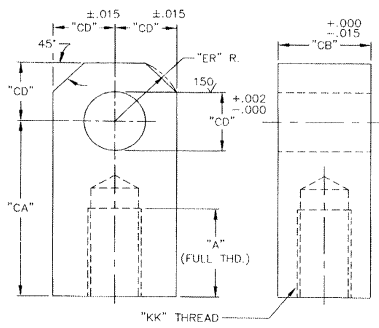

### ROD EYE - Select by 'KK' to Match Rod Thread

Part Number	DIMENSIONS (Inches)						Weight (lbs.)
	A	CA	CB	CD	ER	KK	
R433012610	0.75	1.50	0.75	0.500	0.56	7/16 - 20	0.5
R432006533	0.75	1.50	0.75	0.500	0.56	1/2 - 20	0.5
R433012611	1.13	2.06	1.25	0.750	0.81	3/4 - 16	1.0
R433012612	1.13	2.38	1.50	1.000	1.13	7/8 - 14	2.3
R433012613	1.63	2.81	1.50	1.000	1.13	1 - 14	2.3
R433012614	2.00	3.44	2.00	1.375	1.69	1-1/4 - 12	5.5
R433012615	2.25	4.00	2.50	1.750	2.06	1-1/2 - 12	10.5
R433012616	2.25	4.38	2.50	2.000	2.38	1-3/4 - 12	11.3
R433012617	3.00	5.00	2.50	2.000	2.38	1-7/8 - 12	11.5
R433012618	3.50	5.81	3.00	2.500	2.81	2-1/4 - 12	20.5
R433012648	3.50	6.13	3.00	3.000	3.25	2-1/2 - 12	30.0

### ROD CLEVIS - Select by 'KK' to Match Rod Thread

Part Number	STD. ROD DIA.	DIMENSIONS (Inches)							Weight (lbs.)	
		A	CB	CD	CE	CH	CW	ER		KK
R433012602	0.625	0.75	0.75	0.500	1.50	1.00	0.50	0.50	7/16 - 20	0.5
R433012665	0.625	0.75	0.75	0.500	1.50	1.00	0.50	0.50	1/2 - 20	0.0
R433012603	1.000	1.13	1.25	0.750	2.38	1.25	0.63	0.75	3/4 - 16	0.5
R433012663	1.000	1.13	1.25	0.750	2.38	1.25	0.63	0.75	7/8 - 14	1.3
R433012604	1.375	1.63	1.50	1.000	3.13	1.63	0.75	1.00	1 - 14	2.5
R433012606	1.750	2.00	2.00	1.375	4.13	2.00	1.00	1.38	1-1/4 - 12	6.4
R433012607	2.000	2.25	2.50	1.750	4.50	2.38	1.25	1.75	1-1/2 - 12	11.5
R433012664	2.000	2.25	2.50	1.750	4.50	2.38	1.25	1.75	1-3/4 - 12	11.5
R433012608	2.500	3.00	2.50	2.000	5.50	2.94	1.25	2.00	1-7/8 - 12	14.8
R433012655*	3.000	3.50	3.00	2.500	6.50	3.50	1.50	2.50	2-1/4 - 12	36.0
R433012656*	3.500	3.50	3.00	3.000	6.75	3.88	1.50	3.00	2-1/2 - 12	19.0

\* These clevises include Pivot Pin with Cotter Pins

### PIVOT PIN With Snap Rings

Part Number	Dimensions (Inches)		
	CD	CL	CP
R433012619	0.500	1.88	2.09
R433012621	0.750	2.62	2.88
R433012623	1.000	3.12	3.38
R433012625	1.375	4.19	4.48
Use cotter pin version	1.750	-	-
R433012629	2.000	5.19	5.54
Use cotter pin version	2.500	-	-
Use cotter pin version	3.000	-	-
Use cotter pin version	3.500	-	-

### PIVOT PIN With Cotter Pins

Part Number	Dimensions (Inches)		
	CD	CL	CP
R433014353	0.500	1.94	2.28
R433014354	0.750	2.72	3.10
R433077688	1.000	3.22	3.60
R433014349	1.375	4.25	4.66
R433012627	1.750	5.25	5.66
R433088314	2.000	5.28	5.72
R433012649	2.500	6.31	6.77
R433012650	3.000	6.34	6.84
R433074833	3.500	8.41	8.97

### CLEVIS BRACKET - Select by 'CD' to Match Pin

Part Number	DIMENSIONS (Inches)											Weight (lbs.)	
	AA	CB	CD	CW	DD	E	F	FL	LR	M	MR		R
R433012631	2.30	0.75	0.500	0.50	3/8 - 24	2.50	0.38	1.13	0.63	0.50	0.56	1.63	0.3
R433012632	2.90	1.25	0.750	0.63	1/2 - 20	3.00	0.63	1.88	0.88	0.75	0.88	2.06	0.5
R433012633	3.60	1.25	0.750	0.63	1/2 - 20	3.50	0.63	1.88	0.88	0.75	1.00	2.56	0.8
R433012634	4.60	1.50	1.000	0.75	5/8 - 18	4.50	0.75	2.25	1.19	1.00	1.25	3.25	2.0
R433012635	5.40	2.00	1.375	1.00	5/8 - 18	5.00	0.88	3.00	1.75	1.38	1.63	3.81	0.9
R433012636	7.00	2.50	1.750	1.25	7/8 - 14	6.50	0.88	3.13	2.13	1.75	2.12	4.94	5.1
R433012637	8.10	2.50	2.000	1.25	1 - 14	7.50	1.00	3.50	2.44	2.00	2.38	5.72	8.0
R433012653	10.00	2.50	2.500	1.25	1-1/4-12	9.25	1.75	4.75	2.75	2.50	2.50	7.07	14.8
R433012654	11.70	3.00	3.000	1.50	1-1/2-12	11.00	1.75	5.25	3.25	3.00	3.00	8.27	38.0

### EYE BRACKET - Select by 'CD' to Match Pin

Part Number	DIMENSIONS (Inches)								Weight (lbs.)			
	AA	CB	CD	DB	E	F	FL	LR		MR	R	
R433012638	2.30	0.75	0.500	0.38	2.50	0.38	1.13	0.69	0.50	0.56	1.63	1.0
R433012639	2.90	1.25	0.750	0.50	3.00	0.63	1.88	1.00	0.75	0.88	2.06	3.0
R433012640	3.60	1.25	0.750	0.50	3.50	0.63	1.88	1.00	0.75	0.88	2.56	3.0
R433012641	4.60	1.50	1.000	0.63	4.50	0.75	2.25	1.38	1.00	1.25	3.25	6.3
R433012642	5.40	2.00	1.375	0.63	5.00	0.88	3.00	2.00	1.38	1.62	3.81	10.3
R433012643	7.00	2.50	1.750	0.88	6.50	0.88	3.13	2.25	1.75	2.12	4.94	16.8
R433012644	8.10	2.50	2.000	1.00	7.50	1.00	3.50	2.50	2.00	2.36	5.72	25.3
R433025221	9.32	2.50	2.500	1.25	8.50	1.00	4.00	3.00	2.50	3.00	6.58	35.7
R433038709	10.60	3.00	3.000	1.25	9.50	2.00	5.25	3.25	3.00	3.25	7.50	

# Heavy Duty Pneumatic and Hydraulic NFPA Steel Cylinders

## AVENTICS ACCESSORIES

### Spherical Rod Eye (without pin)

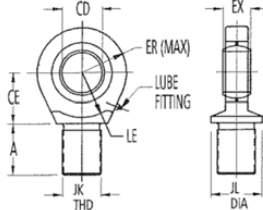

**Notes:**

- Accessories furnished without pivot pin, unless otherwise noted.
- When ordering, please specify AVENTICS part number and description.
- Should your application require accessories not listed, please consult factory.

Part Number	Old Part Number	Dimensions (Inches)								Load Rating (Lbs.)	Wght. (lbs.)
		A	CD	CE	ER	EX	JK	JL	LE		
R433013001	P -048490-00003	0.69	.5000 + .0000 - .0005	0.88	0.88	0.44	7/16-20	0.88	0.75	2,600	0.3
R433012998	P -048490-00000	1.00	.7500 + .0000 - .0005	1.25	1.25	0.66	3/4-16	1.31	1.06	9,400	0.8
R433012999	P -048490-00001	1.50	1.0000 + .0000 - .0005	1.88	1.38	0.88	1-14	1.50	1.44	16,800	1.8
R433013002	P -048490-00004	2.00	1.3750 + .0000 - .0005	2.13	1.81	1.19	1-1/4-12	2.00	1.88	28,600	3.3
R433013003	P -048490-00005	2.13	1.7500 + .0000 - .0005	2.50	2.19	1.53	1-1/2-12	2.25	2.13	43,000	6.0
R433013000	P -048490-00002	2.88	2.0000 + .0000 - .0005	2.75	2.63	1.75	1-7/8-12	2.75	2.50	70,000	10.0

### Self-Aligning Rod End Coupler

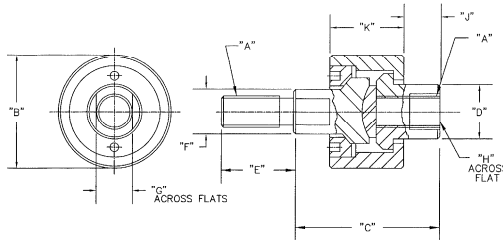

Part Number	Old Part Number	Dimensions (Inches)										*Max. Pull Load	Weight (lbs.)
		A THD.	B	C	D	E	F	G	H	J	K		
R433032614	P -115498-00000	7/16-20	1.56	2.00	0.75	0.75	0.63	0.50	0.63	0.50	1.03	3,250	0.5
R433032615	P -115498-00001	3/4-16	2.13	2.31	1.25	1.13	1.00	0.88	1.13	0.53	1.31	9,050	1.3
R433032616	P -115498-00002	1-14	2.75	3.06	1.50	1.63	1.25	1.13	1.25	0.56	2.00	19,425	3.3
R433032617	P -115498-00003	1-1/4-12	3.50	4.00	2.00	2.00	1.50	1.25	1.69	0.75	2.50	30,825	3.4
R433032618	P -115498-00004	1-1/2-12	4.00	4.38	2.25	2.25	1.75	1.50	1.94	0.87	2.75	45,750	8.3
R433032619	P -115498-00005	1-7/8-12	5.00	5.63	3.00	3.00	2.25	2.00	2.63	1.37	3.37	67,550	14.0
R433032620	P -115498-00006	1-3/4-12	4.00	4.38	2.25	2.25	2.00	1.50	1.94	0.87	2.75	58,350	8.3
R433032621	P -115498-00007	7/8-14	2.12	2.31	1.25	1.12	1.00	0.88	1.12	0.53	1.31	14,450	1.3
R433032622	P -115498-00008	1/2-20	1.56	2.00	0.75	0.75	0.62	0.50	0.62	0.50	1.03	4,450	0.5
R433075033	P -115498-00009	5/8-18	2.12	2.31	1.25	1.12	1.00	0.88	1.12	0.53	1.31	7,150	1.3

\*Load rating has a 4 to 1 safety factor based on yield.

# NOTICE TO PRODUCT USERS

## 1. WARNING: FLUID MEDIA

AVENTICS pneumatic devices are designed and tested for use with filtered, clean, dry, chemical free air at pressures and temperatures within the specified limits of the device. For use with media other than air or for human life support systems, Emerson must be consulted. Hydraulic cylinders are designed for operation with filtered, clean, petroleum based hydraulic fluid; operation using fire-resistant or other special types of fluids may require special packing and seals. Consult the factory.

## 2. WARNING: MATERIAL COMPATIBILITY

Damage to product seals or other parts caused by the use of non-compatible lubricants, oil additives or synthetic lubricants in the air system compressor or line lubrication devices voids the Emerson warranty and can result in product failure or other malfunction. See lubrication recommendations below.

**AIR LINE LUBRICANTS!** In service higher than 18 cycles per minute or with continuous flow of air through the device, an air line lubricator is recommended.\* (Do not use line lubrication with vacuum products.) However, the lubricator must be maintained since the oil will wash out the grease, and lack of lubrication will greatly shorten the life expectancy. The oils used in the lubricator must be compatible with the elastomers in the device. The elastomers are normally BUNA-N, NEOPRENE, VITON, SILICONE and HYTREL. Emerson recommends the use of only petroleum based oils without synthetic additives, and with an aniline point between 180° F and 210° F.

**COMPRESSOR LUBRICANTS!** All compressors (with the exception of special "oil free" units) pass oil mist or vapor from the internal crankcase lubricating system through to the compressed air. Since even small amounts of non-compatible lubricants can cause severe seal deterioration (which could result in component and system failure) special care should be taken in selecting compatible compressor lubricants.

## 3. WARNING: INSTALLATION AND MOUNTING

The user of these devices must conform to all applicable electrical, mechanical, piping and other codes in the installation, operation or repair of these devices.

**INSTALLATION!** Do not attempt to install, operate or repair these devices without proper training in the technique of working on pneumatic or hydraulic systems and devices, unless under trained supervision. Compressed air and hydraulic systems contain high levels of stored energy. Do not attempt to connect, disconnect or repair these products

when a system is under pressure. Always exhaust or drain the pressure from a system before performing any service work. Failure to do so can result in serious personal injury.

**MOUNTING!** Devices should be mounted and positioned in such a manner that they cannot be accidentally operated.

## 4. WARNING: APPLICATION AND USE OF PRODUCTS

The possibility does exist for any device or accessory to fail to operate properly through misuse, wear or malfunction. The user must consider these possibilities and should provide appropriate safe guards in the application or system design to prevent personal injury or property damage in the event of a malfunction.

## 5. WARNING: CONVERSION, MAINTENANCE AND REPAIR

When a device is disassembled for conversion to a different configuration, maintenance or repair, the device must be tested for leakage and proper operation after being reassembled and prior to installation.

**MAINTENANCE AND REPAIR!** Maintenance periods should be scheduled in accordance with frequency of use and working conditions. All AVENTICS products should provide a minimum of 1,000,000 cycles of maintenance free service when used and lubricated as recommended. However, these products should be visually inspected for defects and given an "in system" operating performance and leakage test once a year. Where devices require a major repair as a result of the one million cycles, one year, or routine inspection, the device must be disassembled, cleaned, inspected, parts replaced as required, rebuilt and tested for leakage and proper operation prior to installation. See individual catalogs for specific cycle life estimates.

## 6. PRODUCT CHANGES

Product changes including specifications, features, designs and availability are subject to change at any time without notice. For critical dimensions or specifications, contact factory.

\*Many AVENTICS pneumatic valves and cylinders can operate with or without air line lubrication; see individual sales catalogs for details.

-Refer to the appropriate service manual for parts and service information, most are available for download from [www.Emerson.com/AVENTICS](http://www.Emerson.com/AVENTICS)

## WARRANTIES

7.1 Emerson warrants that:

- Emerson will transfer title to the Goods (excluding Software and Firmware) to Customer under Clause 4 of our Terms and Conditions of Sale\*;
- Goods, Documentation and Services will conform with the Specification;
- Goods made by Emerson or its Affiliates will, under normal use and care, be free from defects in materials or workmanship; and
- Emerson and its Affiliates' Personnel delivering Services are trained and will use reasonable skill and care.

7.2 **Warranty Periods.** Unless otherwise specified by Emerson, the warranties in Clause 7.1 apply as follows:

- Goods:** until the earlier of 12 months from the first installation or 18 months from delivery (90 days from delivery in the case of consumables);
- Services:** for 90 days from completion of the Services;
- Goods repaired, replacement items and Services re-performed:** from delivery of the replacement or completion of the repair or re-performance, for 90 days or until the end of the original warranty period (if later).

7.3 **Warranty Procedure.** Clause 7.3 applies if, within the warranty period, Customer discovers any non-conformity with a warranty in Clause 7.1, tells Emerson in writing and, in the case of Goods, returns the non-conforming items at Customer's cost, freight and insurance pre-paid, to the repair facility chosen by Emerson. Where this Clause applies, Emerson will, at its sole option, either:

- correct any non-conforming Documents and Services; or
- repair or replace non-conforming Goods FCA (Incoterms® 2010) at the repair location; or
- instead refund the price of the non-conforming item.

### 7.4 Exclusions from Warranty.

- The warranties in Clause 7.1(b), (c) and (d) exclude and Customer will pay the cost of all repairs and replacements caused by any of the following: normal wear and use; inadequate maintenance; unsuitable power sources or environmental conditions; improper handling, storage, installation, or operation; misuse or accident caused by anybody except Emerson; a modification or repair not approved by Emerson in writing; materials or workmanship made, provided or specified by Customer; contamination; the use of unapproved parts, firmware or software; Cyber Attack; any other cause not the fault of Emerson.
- Emerson will not pay any costs relating to non-compliance with a warranty in Clause 7.1, except where agreed in writing in advance. Unless accepted in writing by Emerson, Customer will pay:
  - all costs of dismantling, freight, reinstallation and the time and expenses of Emerson Personnel for travel under Clause 7; and
  - all costs incurred by Emerson in correcting nonconformities for which Emerson is not responsible under Clause 7 and in examining items that comply with the warranties in Clause 7.1.
- If Emerson relies on wrong or incomplete information supplied by Customer, all warranties are void unless Emerson agrees otherwise in writing.
- Customer alone is responsible for the selection, maintenance and use of the Goods.

e) Resale Products carry only the warranty given by the original manufacturer. Emerson has no liability for Resale Products beyond making a reasonable commercial effort to arrange procurement and shipping of the Resale Products.

7.5 **Disclaimer.** The limited warranties set out in this Clause 7 are the only warranties made by Emerson and can be changed only with Emerson's signed written agreement. THE WARRANTIES AND REMEDIES IN CLAUSE 7 ARE EXCLUSIVE. THERE ARE NO REPRESENTATIONS OR WARRANTIES OF ANY KIND, EXPRESS OR IMPLIED, ABOUT MERCHANTABILITY, FITNESS FOR PARTICULAR PURPOSE OR ANYTHING ELSE FOR ANY OF THE GOODS, DOCUMENTATION OR SERVICES.

\*Additional conditions apply - for full details, visit our website to download our Terms and Conditions of Sale:  
[www.Emerson.com/AVENTICS](http://www.Emerson.com/AVENTICS)

# Efficient pneumatic solutions: cylinders and drives, valves and valve systems, air supply management.

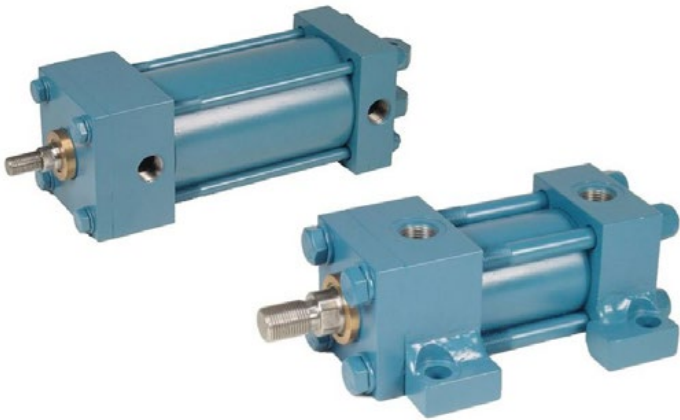

**AVENTICS™**

Visit us: [Emerson.com/AVENTICS](https://emerson.com/AVENTICS)

Your local contact: [Emerson.com/contactus](https://emerson.com/contactus)



[Emerson.com](https://emerson.com)



[Facebook.com/EmersonAutomationSolutions](https://facebook.com/EmersonAutomationSolutions)



[LinkedIn.com/company/Emerson-Automation-Solutions](https://linkedin.com/company/Emerson-Automation-Solutions)



[Twitter.com/EMR\\_Automation](https://twitter.com/EMR_Automation)

The Emerson logo is a trademark and service mark of Emerson Electric Co. Brand logotype are registered trademarks of one of the Emerson family of companies. All other marks are the property of their respective owners. © 2022 Emerson Electric Co. All rights reserved.  
TR000332ENUS-01\_09-22



**CONSIDER IT SOLVED™**