

H2 Valve Series - Hydrogen Applications

15,000 psig (103.4 MPa) and 10,000 (68.95 MPa) Pressure Ranges | Anderson Greenwood Instrumentation Instrument Valves

The H2 Valve series is designed to provide enhanced sealing performance for hydrogen at 15,000 psig (103.4 MPa). The design prevents media leakage to the environment and protects operators following the isolation of process pressure during routine instrument maintenance.

General Application

Emerson's TESCOM™ Anderson Greenwood Instrumentation Valves H2 Series are designed for isolation purposes for use in high-pressure gas applications including hydrogen fueling stations. The H2 Valve Series' design utilizes stem seal technology that provides consistent pressure containment with low operating torque makes it an ideal solution for hydrogen fuel dispensing systems.

The H2 Valve Series allows hydrogen fueling station manufacturers and integrators to minimize operational service costs and potential leakage, by providing a reliable, low-maintenance solution. This H2 Series meets the ISO 19880.3 requirements of 700 bar H70 Station Rating on Hydrogen Fuel Station Applications. It's compact, lightweight, ergonomic design improves installation and operational activities.

The overall design pressure and temperature rating of 15,000 psig (103.4 MPa) at -70°F to 400°F (-57°C to 204°C) allows this valve to be utilized in other hydrogen, gas, and liquid applications where positive shut-off is required and bonnet leakage is a concern.

TECHNICAL DATA

Materials

316 Stainless Steel

Seats:

Integral metal to metal

Connections

1/4", 3/8", 1/2" & 9/16" NPT & MP

Orifice size:

0.236 in (6.0 mm)

Pressure rating:

(mcwp):

15,000 psig (103.4 MPa)

Temp range:

design min/max:

-70°F to 400°F (-57°C to 204°C)

CV = 0.63 Maximum Open Position of Valve Bonnets



Double Block and Bleed

Single Block

Features

- Ease of installation and operations due to lighter, compact design and Double Block & Bleed bonnet ergonomics
- Positive shutoff performance, non-rotating stem tip
- Low fugitive emissions stem seal arrangement
- No stem packing adjustment during operational service
- Double Block & Bleed configuration provides 'true' process isolation at closure shut-off point (process path)
- Available in various configurations to suit instrumentation valve applications for the full range of system designs
- Visual identification of valve bonnet function with color-coded bonnet collar tags
- Safety weep holes for packing and process connection integrity
- 15K Valves tested for compliance to ISO 19880.3 Valves : Gaseous Hydrogen Fueling Stations
- QR code for quick access to online product documentation, local support, and distribution

Testing

All H2 Series Valves are factory production tested in accordance with our standard manufacturing procedures. Shell and seat tests are performed to verify bubble-free integrity.

H2 Valve Series - Hydrogen Applications

15,000 psig (103.4 MPa) and 10,000 (68.95 MPa) Pressure Ranges | Anderson Greenwood Instrumentation Instrument Valves

Dimensions

Dimensions are for reference only and may be subject to change.

Dimensions, inches (mm)

H2DB Series (Block / Bleed /Block configuration)

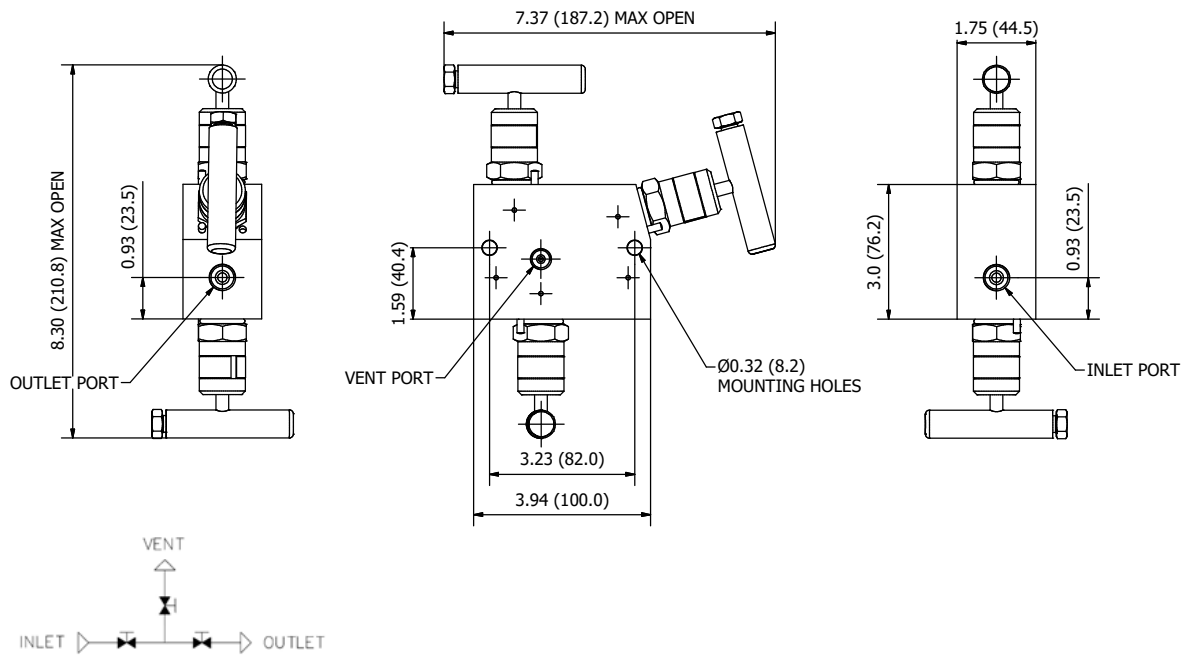

INLET/OUTLET	VENT	A	B
1/4" MP	1/4" MP	3.94" (100.0 mm)	3.23" (82.0 mm)
3/8" MP	1/4" MP	3.94" (100.0 mm)	3.23" (82.0 mm)
9/16" MP	1/4" MP	4.19" (106.4 mm)	3.48" (88.4 mm)
1/4" NPT	1/4" NPT	3.94" (100.0 mm)	3.23" (82.0 mm)
1/2" NPT	1/4" NPT	3.94" (100.0 mm)	3.23" (82.0 mm)

H2 Valve Series - Hydrogen Applications

15,000 psig (103.4 MPa) and 10,000 (68.95 MPa) Pressure Ranges | Anderson Greenwood Instrumentation Instrument Valves

H2BB Series (Block and Bleed configuration)

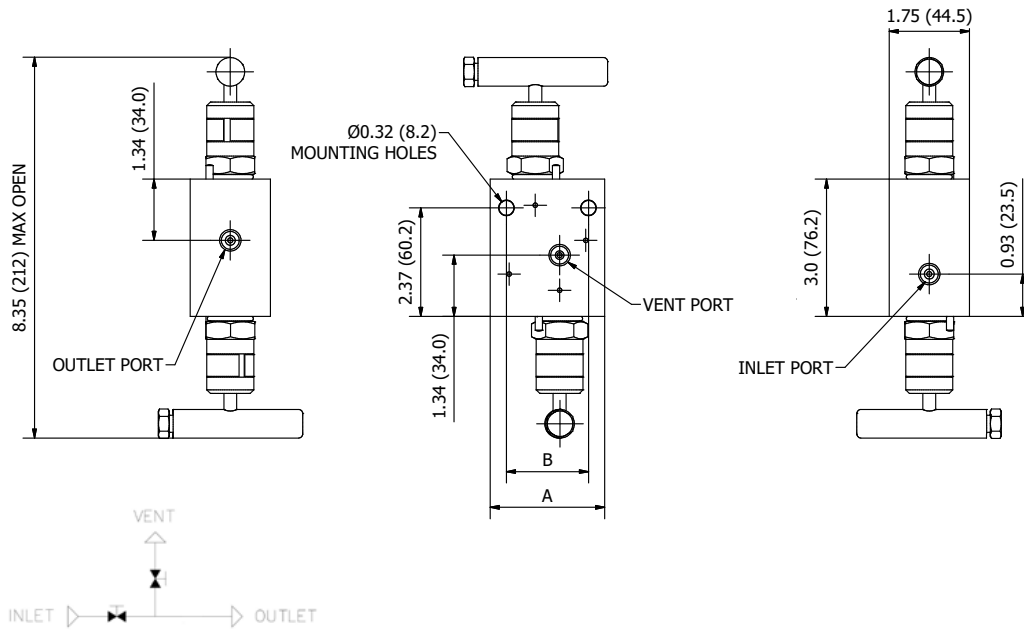

INLET/OUTLET	VENT	A	B
1/4" MP	1/4" MP	2.5" (63.5 mm)	1.79" (45.5 mm)
3/8" MP	1/4" MP	2.5" (63.5 mm)	1.79" (45.5 mm)
9/16" MP	1/4" MP	3.0" (76.2 mm)	2.29" (58.2 mm)
1/4" NPT	1/4" NPT	2.5" (63.5 mm)	1.79" (45.5 mm)
1/2" NPT	1/4" NPT	3.0" (76.2 mm)	2.29" (58.2 mm)

H2SB Series (Single Block configuration)

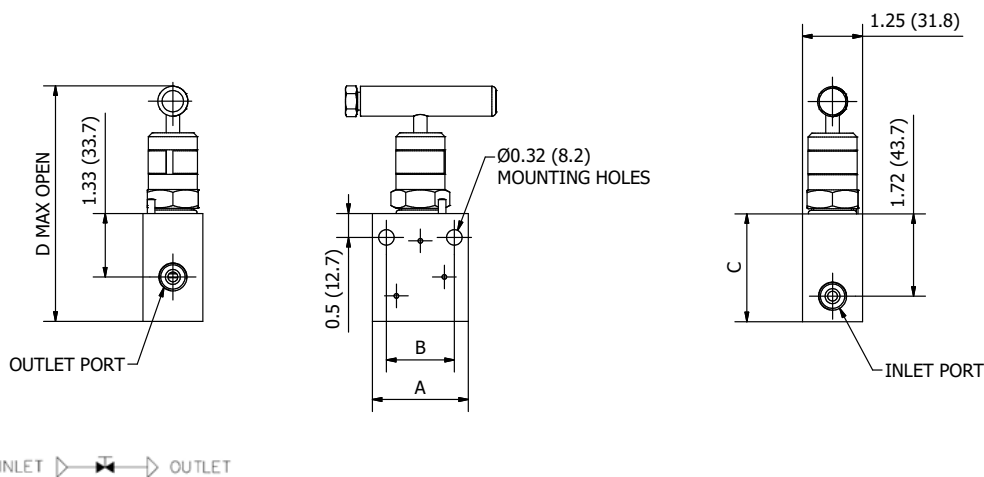

INLET/OUTLET	A	B	C	D
1/4" MP	2.0" (50.8 mm)	1.42" (36.0 mm)	2.25" (57.2 mm)	4.91" (124.8 mm)
3/8" MP	2.0" (50.8 mm)	1.42" (36.0 mm)	2.25" (57.2 mm)	4.91" (124.8 mm)
9/16" MP	2.5" (60.3 mm)	1.92" (49.7 mm)	2.5" (60.3 mm)	5.16" (131.1 mm)
1/4" NPT	2.0" (50.8 mm)	1.42" (36.0 mm)	2.25" (57.2 mm)	4.91" (124.8 mm)
1/2" NPT	2.5" (60.3 mm)	1.92" (49.7 mm)	2.5" (60.3 mm)	5.16" (131.1 mm)

H2 Valve Series - Hydrogen Applications

15,000 psig (103.4 MPa) and 10,000 (68.95 MPa) Pressure Ranges | Anderson Greenwood Instrumentation Instrument Valves

Qualification / Certification

Internally qualified and certified to ISO 19880.3: Shutoff Valves using helium media

Selection Guideline

Selection Guide Sample							
H2	DB	BV	I	S	3	MP	HA

MODEL SERIES	CONFIGURATION	PACKING	SEAT MATERIAL	BODY MATERIAL	CONNECTION TYPE	CONNECTIONS	OPTIONS
H2	DB Double Block & Bleed Valve	BV B-Type Modified PTFE	I Integral	S 316 SS	5 9/16" Female (Inlet/Outlet)	MP API Medium Pressure	HA Hydrogen Fuel Station Application to ISO 19880-3 (15,000 psig applications only)
H2	BB Block & Bleed Valve				4 9/16" Female (Inlet/Outlet)		T2 FNPT
H2	SB Single Block Valve				3 3/8" Female (Inlet/Outlet)		
					2 1/4" Female (Inlet/Outlet)		

NOTE*

Vent Ports size 1/4" (MP/FNPT)

All FNPT threaded Valves are rated to 10,000 psig maximum

Please consult Customer Service Team for specific requirements not outlined.