



OFFSHORE PROCESSING PLATFORM ENHANCES SPACE AND SAFETY WITH ROSEMOUNT™ ORIFICE ASSEMBLIES

Customer

South East Asian Processing Platform

Application

Measuring the Flow of Heating Oil

Challenge

Offshore platforms are a demanding environment and oil production is a difficult and potentially dangerous operation. Safety is a concern in all oil production, on or off shore, but offshore isolation and the sea itself adds to the risks. Also, with expensive real estate, “spare” room is very limited. Anyone supplying equipment to a platform is highly aware that it must be compact, reliable, and rugged and, above all, meet stringent safety conditions.

Crude oil extracted from below the seabed has to pass through several processes. It has to be cleaned and scrubbed removing any impurities, such as seawater. This process is costly, but it can improve efficiency by as much as 50% or more if the temperature of the extracted product is raised.

A New Zealand company won the contract to provide oil heating equipment for a South East Asian processing platform. They had developed suitable gas heating technology and had provided equipment for other offshore facilities. The process involves circulating heating oil to warm the cooler product, but a reliable instrument is needed to measure the flow of the heating oil.

Considering the size of the pipes (8-in. or 200 mm), the most suitable measurement technology seemed to be the orifice plate. They're simple and reliable and the associated DP transmitters can be made intrinsically safe with barriers. Traditional systems need isolation valves, manifolds and

Results

- More efficient use of space
- Improved safety in a dangerous environment
- Improved reliability in harsh conditions



3051SFC Compact Conditioning Orifice Flow Meter

OFFSHORE PROCESSING PLATFORM ENHANCES SPACE AND SAFETY WITH ROSEMOUNT™ ORIFICE ASSEMBLIES

impulse lines, which all have connections that are potentially dangerous leakage points.

Unfortunately though, there's another problem, which is space for an orifice plate installation. Orifice plates require long upstream and downstream straight length runs to meet the standard calibration conditions; runs that require room not available on a platform or, at least, not without cost.

Solution

When the difficulties and conditions were explained, the Emerson engineer was confident providing the Rosemount™ 3051SFC Compact Conditioning Orifice Flow Meter solution.

Space

Conditioning orifice plates have long been used where space is limited, however, the flow calculations have not been reliable or consistent. Rosemount developed a new orifice technology with the conditioning orifice plate that is reliable and predictable, which only requires two diameters of straight pipe length upstream and downstream.

Safety

Leakage points are potentially dangerous on an oil production facility. The 405C minimizes that potential. A three-valve isolation manifold and a 1-in. (25 mm) thick wafer-style body allows direct mounting, while eliminating all field connections between the process and the differential pressure-measuring device. With an integrated 3051S, the inexpensive yet robust assembly provides an easy installation. Most importantly though, it eliminates many of the potentially dangerous leakage points inherent in traditional orifice plate installations.

Reliability

The offshore environment is certainly not friendly. The Rosemount 3051S Differential Pressure Transmitter, however, has an all-welded, 316L SST hermetically sealed SuperModule which houses the single board electronics, protecting them from moisture and field contaminants. The 3051S can withstand the most hostile environments.

Emerson supplied the four flow meters configured, calibrated and pressure tested. Each orifice assembly was fitted with isolating valves and two transmitters; one providing a signal for the local heating system, the other a signal to the platform's main control system.

When the difficulties and conditions were explained, the Emerson engineer was confident that he had the solution - the Rosemount 405C Conditioning Orifice Plate with 3051S Differential Pressure Transmitters.



Comparison of required straight pipe lengths (Conditioning Orifice Plate vs. Traditional Orifice Plate)

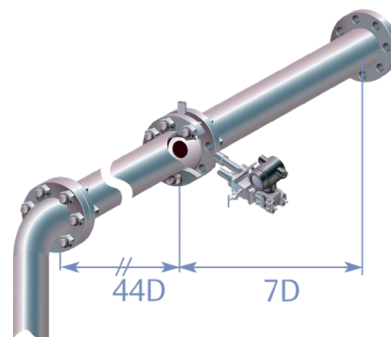

OFFSHORE PROCESSING PLATFORM ENHANCES SPACE AND SAFETY WITH ROSEMOUNT™ ORIFICE ASSEMBLIES

The customer was particularly impressed with the safety aspect and the quality of the 405C, observing that the single piece design solved many safety issues.

The Emerson logo is a trademark and service mark of Emerson Electric Co.
Brand logotype are registered trademarks of one of the Emerson family of companies.
All other marks are the property of their respective owners.
© 2024 Emerson Electric Co.
All rights reserved.

For more information, visit
[Emerson.com/Oil-Gas](https://www.emerson.com/Oil-Gas)
[Emerson.com/DPFlow](https://www.emerson.com/DPFlow)

00830-0500-4810, Rev BB

ROSEMOUNT™

