

Introduction

This installation guide provides instructions for installation, startup and adjustment. To receive a copy of the instruction manual, contact your local Sales Office or view a copy at www.fisher.com. For further information refer to: Types 66, 66Z and 66ZZ Instruction Manual, D100247X012.

PED Categories

This product may be used as a safety accessory with pressure equipment in the following Pressure Equipment Directive categories. It may also be used outside of the Pressure Equipment Directive using sound engineering practice (SEP) per table below. For information on the current PED revision see Bulletin: [D103053X012](#).

PRODUCT SIZE	CATEGORIES	FLUID TYPE
DN 50 to 100 / 2 to 4 in.	SEP	1

Specifications

Body Sizes and Styles

See Table 1

Maximum Allowable Inlet Pressures⁽¹⁾

Emergency Inlet Pressure:

Type 66, 66Z, 66ZZ or 66 Series Vacuum Breakers: 1.72 bar / 25 psig positive pressure
66 Series Vacuum Regulators: 0.55 bar differential / 8 psig or 16.3 in. Hg vacuum

Maximum Safe Pressure to Avoid Internal Parts Damage:

Type 66: 0.69 bar / 10 psig
Type 66Z: 0.34 bar / 5 psig
Type 66ZZ: 0.14 bar / 2 psig
66 Series Vacuum Regulators or Breakers:
No more than 0.07 bar differential / 1 psig change from spring setting

Maximum Operating Inlet Pressure Recommended for Good Performance:

Type 66, 66Z or 66 Series Vacuum Breakers:
0.34 bar / 5 psig positive pressure
Type 66ZZ: 0.14 bar / 2 psig
66 Series Vacuum Regulator: 15 mbar differential / 6 in. w.c. or 0.4 in. Hg vacuum

Maximum Allowable Outlet Pressures⁽¹⁾

Emergency Outlet (Casing) Pressure:

Type 66, 66Z or 66ZZ: 0.55 bar / 8 psig positive pressure

66 Series Vacuum Regulator: 1.01 bar differential / 14.7 psi or 29.9 in. Hg vacuum

66 Series Vacuum Breakers: 0.55 bar differential / 8 psi or 16.3 in. Hg vacuum

Maximum Safe Pressure to Avoid Internal Parts Damage:

Type 66, 66Z or 66ZZ: 0.07 bar differential / 1 psig above outlet pressure setting

66 Series Vacuum Regulator: No more than 0.07 bar differential / 1 psig change from spring setting

Maximum Operating Pressure Recommended for Good Performance (66 Series Vacuum Regulators or Breakers Only):

Vacuum Regulators: 0.69 bar differential / 10 psig or 20.4 in. Hg vacuum

Vacuum Breakers: 15 mbar differential / 6 in. w.c. or 0.4 in. Hg vacuum

Proof Test Pressure

All Pressure Retaining Components have been proof tested per Directive.

Outlet Control Pressure Ranges⁽¹⁾

See Table 2

Elastomer Temperature Capabilities

Nitrile (NBR) Standard Elastomers: -40 to 82°C / -40 to 180°F

Fluorocarbon (FKM) Elastomers: -18 to 177°C / 0 to 350°F

Ethylene propylene (EPDM) Elastomers: -40 to 135°C / -40 to 275°F

Installation

WARNING

Only qualified personnel should install or service a regulator. Regulators should be installed, operated and maintained in accordance with international and applicable codes and regulations and Emerson Process Management Regulator Technologies, Inc. instructions.

If the regulator vents fluid or a leak develops in the system, it indicates that service is required. Failure to take the regulator out of service immediately may create a hazardous condition.

1. The pressure/temperature limits in this installation guide and any applicable standard or code limitation should not be exceeded.

Types 66, 66Z and 66ZZ

Personal injury, equipment damage or leakage due to escaping fluid or bursting of pressure-containing parts may result if this regulator is overpressured or is installed where service conditions could exceed the limits given in the Specifications section, or where conditions exceed any ratings of the adjacent piping or piping connections.

To avoid such injury or damage, provide pressure-relieving or pressure-limiting devices (as required by the appropriate code, regulation or standard) to prevent service conditions from exceeding limits.

Additionally, physical damage to the regulator could result in personal injury and property damage due to escaping fluid. To avoid such injury and damage, install the regulator in a safe location.

Clean out all pipelines before installation of the regulator and check to be sure the regulator has not been damaged or has collected foreign material during shipping. For NPT bodies, apply pipe compound to the external pipe threads. For flanged bodies, use suitable line gaskets and approved piping and bolting practices. Install the regulator in any position desired, unless otherwise specified, but be sure flow through the body is in the direction indicated by the arrow on the body.

Install Types 66, 66Z and 66ZZ regulators horizontally with the spring case vertically above the valve body.

Note

It is important that the regulator be installed so that the vent hole in the spring case is unobstructed at all times. For outdoor installations, the regulator should be located away from vehicular traffic and positioned so that water, ice and other foreign materials cannot enter the spring case through the vent. Avoid placing the regulator beneath eaves or downspouts, and be sure it is above the probable snow level.

With steel bodies, an external control line is required. Connect DN 20 / 3/4 in. NPT control line to the lower diaphragm casing connection from the point where the downstream pressure is to be sensed.

Overpressure Protection

The recommended pressure limitations are stamped on the regulator nameplate. Some type of

overpressure protection is needed if the actual inlet pressure exceeds the maximum operating outlet pressure rating. Overpressure protection should also be provided if the regulator inlet pressure is greater than the safe working pressure of the downstream equipment.

Regulator operation below the maximum pressure limitations does not preclude the possibility of damage from external sources or debris in the line. The regulator should be inspected for damage after any overpressure condition.

Startup

The regulator is factory set at approximately the midpoint of the spring range or the pressure requested, so an initial adjustment may be required to give the desired results. With proper installation completed and relief valves properly adjusted, slowly open the upstream and downstream shutoff valves.

Adjustment

To change the outlet pressure, remove the closing cap or loosen the locknut and turn the adjusting screw clockwise to increase outlet pressure or counterclockwise to decrease pressure. Monitor the outlet pressure with a test gauge during the adjustment. Replace the closing cap or tighten the locknut to maintain the desired setting.

Taking Out of Service (Shutdown)



To avoid personal injury resulting from sudden release of pressure, isolate the regulator from all pressure before attempting disassembly.

Parts List

Key	Description
1	Valve Body
2	Upper Diaphragm Casing
3	Lower Diaphragm Casing
4	Diaphragm Plate
5*	Diaphragm
6	Spring
7	Bottom Flange
8*	O-ring
9	Disk Retainer
10	Valve Plug Skirt
11	Seat Ring
12	Pitot Tube
13	Valve Plug System
14*	Balancing Diaphragm
15	Sealing Diaphragm Plate
16	Diaphragm Spacer
17	Lower Spring Seat, Types 66 and 66Z only
18*	Stem Gasket
19*	Bottom Flange Gasket
20	Cap Screw

*Recommended spare part.

Types 66, 66Z and 66ZZ

Table 1. Body Sizes and End Connection Styles⁽¹⁾

NOMINAL BODY SIZE		END CONNECTION STYLES AND RATINGS ⁽¹⁾	
DN	In.	Standard Cast Iron Body	Optional Steel Body
50	2	NPT or CL125 FF	NPT (all types), CL150 RF (all types), CL150 FF, CL300 RF
80, 100	3, 4	CL125 FF	CL150 RF

Table 2. Outlet Pressure Ranges

Type	OUTLET PRESSURE RANGES	
	mbar	in. w.c.
66	10 to 27	4 to 11
	20 to 70	8 to 28
	5 to 12	2 to 5
	10 to 20	4 to 8
	17 to 30	7 to 12
66Z	25 to 42	10 to 17
	35 to 70	14 to 28
	0.05 to 0.10 bar	0.75 to 1.5 psig
	0.07 to 0.14 bar	1 to 2 psig
66ZZ	0.10 to 0.21 bar	1.5 to 3 psig
	0.21 to 0.34 bar	3 to 5 psig
	-2.5 to 5	-1 to 2
66ZZ	-0.6 to 0.6	-0.25 to 0.25
66 Series vacuum regulators or breakers	0 to -5	0 to -2
	-0.7 to -2	-0.2 to -0.8
	-5 to -15	-2 to -6

Parts List

Key Description

- 21 Cap Screw
- 22 Hex Nut
- 23 Stop Nut
- 25 Adjusting Screw
- 26* Closing Cap Gasket
- 27 Closing Cap
- 28 Flapper Valve
- 29 Snap Ring
- 30 Y602-10 Vent Assembly
- 31 Pipe Plug (not shown)
- 34 Washer
- 35* Gasket
- 36 Washer, Types 66 and 66Z only
- 37 Sealing Washer
- 38 Counter Spring, Type 66Z only
- 43 Spring Retainer, Type 66ZZ only
- 44 Set Screw, for Type 66 with external control line and adjustable travel stops
- 45 Hex Nut, for Type 66 with external control line and adjustable travel stops
- 46 Adjusting Screw Cap, for Type 66 with external control line and adjustable travel stops
- 47 Adjusting Cap Gasket, for Type 66 with external control line and adjustable travel stops
- 48 Upper Travel Stop, for Type 66 with external control line and adjustable travel stops
- 49 Lower Travel Stop, for Type 66 with external control line and adjustable travel stops
- 50 Lock Washer, for Type 66 with external control line and adjustable travel stops
- 51 Plug
- 52 Spring Case Coupling, Type 66ZZ only
- 53 Spring Case Extension, Type 66ZZ only
- 54 Ball, Type 66ZZ only
- 57 Retaining Ring, Type 66ZZ only
- 66* Casing Gasket
- 68 Flow Arrow
- 69 Drive Screw

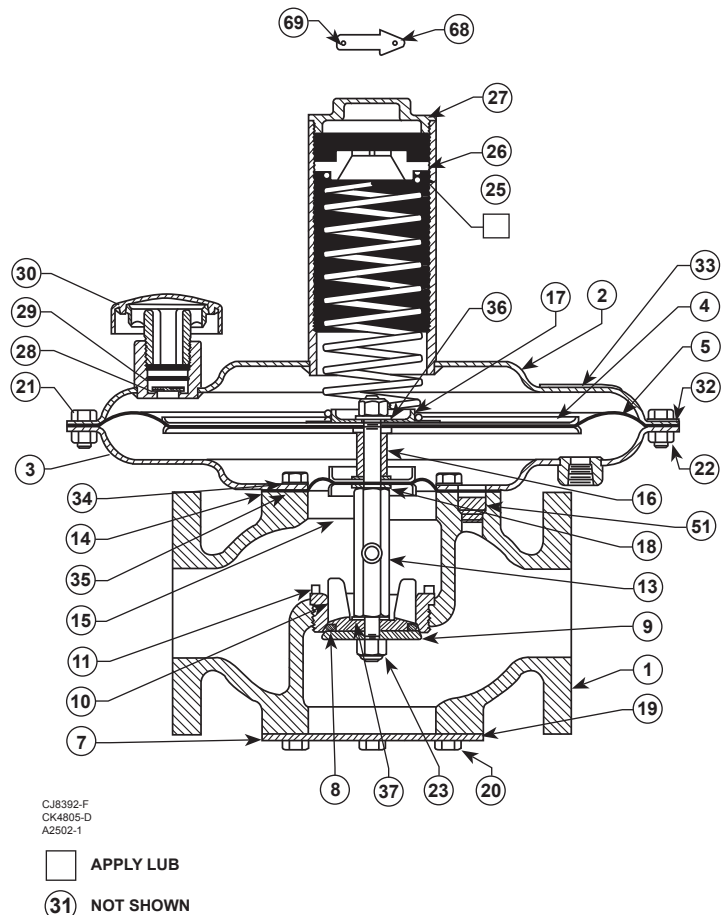

Figure 1. Soft-Seated Type 66 Regulator (with external control line)

*Recommended spare part.

Type 66, 66Z and 66ZZ

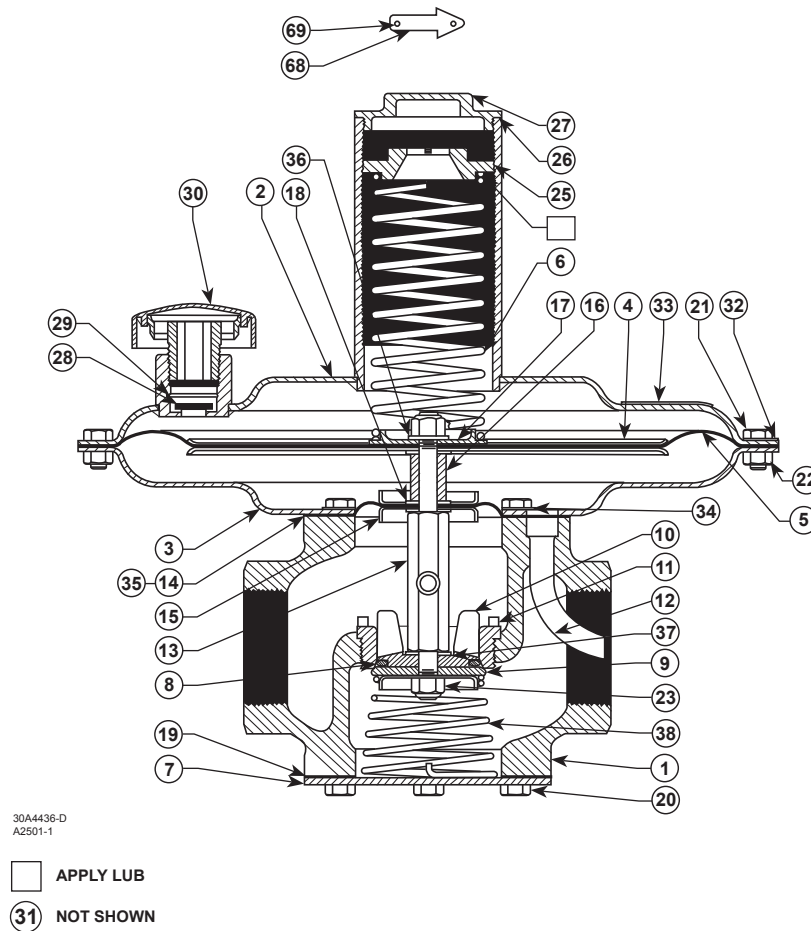

Figure 2. Type 66Z Regulator

✉ Webadmin.Regulators@emerson.com

Facebook.com/EmersonAutomationSolutions

🔍 Fisher.com

LinkedIn.com/company/emerson-automation-solutions

Twitter.com/emr_automation

Emerson Automation Solutions

Americas

McKinney, Texas 75070 USA
T +1 800 558 5853
+1 972 548 3574

Asia Pacific

Singapore 128461, Singapore
T +65 6777 8211

Europe

Bologna 40013, Italy
T +39 051 419 0611

Middle East and Africa

Dubai, United Arab Emirates
T +971 4 811 8100

D100247X014 © 2002, 2018 Emerson Process Management Regulator Technologies, Inc. All rights reserved. 09/18.

The Emerson logo is a trademark and service mark of Emerson Electric Co. All other marks are the property of their prospective owners. Fisher™ is a mark owned by Fisher Controls International LLC, a business of Emerson Automation Solutions.

The contents of this publication are presented for information purposes only, and while effort has been made to ensure their accuracy, they are not to be construed as warranties or guarantees, express or implied, regarding the products or services described herein or their use or applicability. All sales are governed by our terms and conditions, which are available on request. We reserve the right to modify or improve the designs or specifications of our products at any time without notice.

Emerson Process Management Regulator Technologies, Inc does not assume responsibility for the selection, use or maintenance of any product. Responsibility for proper selection, use and maintenance of any Emerson Process Management Regulator Technologies, Inc. product remains solely with the purchaser.



For further information on the current PED revision see Bulletin: [D103053X012](#) or scan the QR code.

