

TESCOM 50-4X Series

Safety, Installation & Start-Up Procedures



**Do not attempt to select, install, use
or maintain this product until you have
read and fully understood this manual.**

Contents

Section 1: Symbols	4
Section 2: Safety, Installation and Operations Precautions	4
2.1 Installation	6
2.2 Repair Service	6
Section 3: Installation	7
3.1 Introduction.....	7
3.2 Specifications.....	7
3.3 Installation Diagram.....	8
3.4 Installation	8
Section 4: Start-up Procedure	10

Section 1: Symbols

CAUTION

Paragraphs highlighted by the **CAUTION** icon contain information that must be followed to maintain a safe and successful operating environment.

WARNING

Paragraphs highlighted by the **WARNING** icon contain information about practices or circumstances that can lead to personal injury or death, property damage or economic loss.

Section 2: Safety, Installation and Operations Precautions

WARNING

 Do not attempt to select, install, use or maintain this regulator, valve or accessory until you have read and fully understand these instructions.

Be sure this information reaches the operator and stays with the product after installation.

Do not permit untrained persons to install, use or maintain this regulator, valve or accessory.

Improper selection, improper installation, improper maintenance, misuse or abuse of regulators, valves or related accessories can cause death, serious injury and/or property damage.

Oxygen service requires special expertise and knowledge of system design and material compatibility in order to minimize the potential for death, serious injury and/or property damage.

Possible consequences include but are not limited to:

- High velocity fluid (gas or liquid) discharge
- Parts ejected at high speed
- Contact with fluids that may be hot, cold, toxic or otherwise injurious
- Explosion or burning of the fluid
- Lines/hoses whipping dangerously
- Damage or destruction to other components or equipment in the system

▲ CAUTION

Safety Precautions

1. Inspect the regulator, valve and accessories before each use.
2. Never connect regulators, valves or accessories to a supply source having a pressure greater than the maximum rated pressure of the regulator, valve or accessory.
3. Refer to product label (model specific) for maximum inlet pressures. If this rated pressure cannot be found, contact your local TESCO representative for the rated pressure prior to installation and use. Verify the designed pressure rating of all equipment (e.g., supply lines, fittings, connections, filters, valves, gauges, etc.) in your system. All must be capable of handling the supply and operating pressure.
4. Clearly establish flow direction of the fluid before installation of regulators, valves and accessories. It is the responsibility of the user to install the equipment in the correct direction.
5. Remove pressure from the system before tightening fittings, gauges or components.
6. Never turn regulator or valve body. Instead hold regulator or valve body and turn fitting nut.
7. If a regulator or valve leaks or malfunctions, take it out of service immediately.
8. Do not modify equipment or add attachments not approved by the manufacturer.
9. Apply pressure to the system gradually, avoiding a sudden surge of fluid or pressure shock to the equipment in the system.
10. Regulators are not shut-off devices. Install a pressure relief device downstream of the regulator to protect the process equipment from overpressure conditions. Shut off the supply pressure when the regulator is not in use.
11. Periodic inspection and scheduled maintenance of your equipment is required for continued safe operation.
12. The frequency of servicing is the responsibility of the user based on the application. Positive seal/tied diaphragm regulators require the downstream pressure vented before turning the hand knob counterclockwise to reduce the outlet pressure. Damage may occur to the regulator if this procedure is not followed.
13. Never allow problems or lack of maintenance to go unreported.
14. Read and follow precautions on compressed gas cylinder labels.
15. It is important that you analyze all aspects of your application and review all available information concerning the product or system. Obtain, read and understand the Material Safety Data Sheet (MSDS) for each fluid used in your system.
16. Never use materials for regulators, valves or accessories that are not compatible with the fluids being used.
17. Users must test components for material compatibility with the system operating conditions prior to use in the system.
18. Vent fluids to a safe environment and in an area away from employees. Be sure that venting and disposal methods are in accordance with Federal, State and Local requirements. Locate and construct vent lines to prevent condensation or gas accumulation. Make sure the vent outlet is not obstructed by rain, snow, ice, vegetation, insects, birds, etc. Do not interconnect vent lines; use separate lines if more than one vent is needed.

19. Do not locate regulators, valves or accessories controlling flammable fluids near open flames or any other source of ignition.
20. Some fluids when burning do not exhibit a visible flame. Use extreme caution when inspecting and/or servicing systems using flammable fluids to avoid death or serious injury to employees. Provide a device to warn employees of these dangerous conditions.
21. Many gases can cause suffocation. Make certain the area is well ventilated. Provide a device to warn employees of lack of Oxygen.
22. Never use oil or grease on these regulators, valves or accessories. Oil and grease are easily ignited and may combine violently with some fluids under pressure.
23. Have emergency equipment in the area if toxic or flammable fluids are used.
24. Upstream filters are recommended for use with all fluids.
25. Do not bleed system by loosening fittings.
26. Prevent icing of the equipment by removing excess moisture from the gas.
27. Always use proper thread lubricants and sealants on tapered pipe threads.

2.1 Installation

CAUTION

Do not open packaging until ready for installation or in a clean environment. Product is cleaned in accordance with CGA 4.1 and ASTM G93, Verification Type 1, Test 1 and Test 2. With periodic verification of cleaning process to MIL-STD-1330D.

WARNING

Make sure that the components and materials used in the fluid handling system are compatible with the fluid and have the proper pressure rating. Failure to do so can result in death, serious injury and/or property damage.

Inspect the regulator, valve and accessories for physical damage and contamination. Do not connect the regulator, valve or accessory if you detect oil, grease or damaged parts. If the regulator, valve or accessory is damaged, contact your local TESCOM representative to have the regulator cleaned or repaired.

2.2 Repair Service

If a regulator or valve leaks or malfunctions, take it out of service immediately. You must have instructions before doing any maintenance. Do not make any repairs you do not understand. Have qualified personnel make repairs. Return any equipment in need of service to your equipment supplier for evaluation and prompt service. Equipment is restored to the original factory performance specifications, if repairable. There are flat fee repair charges for each standard model. The original equipment warranty applies after a complete overhaul.

⚠ CAUTION

Proper Component Selection

1. Consider the total system design when selecting a component for use in a system.
2. The user is responsible for assuring all safety and warning requirements of the application are met through his/her own analysis and testing.
3. TESCO may suggest material for use with specific media upon request. Suggestions are based on technical compatibility resources through associations and manufacturers. TESCO does NOT guarantee materials to be compatible with specific media — THIS IS THE RESPONSIBILITY OF THE USER!
4. Component function, adequate ratings, proper installation, operation and maintenance are the responsibilities of the system user.

⚠ WARNING

Do not modify equipment or add attachments not approved by the manufacturer. Failure to do so can result in death, serious injury and/or property damage.

ASSEMBLY/INSTALLATION DRAWINGS AND BILLS OF MATERIAL drawings and parts lists for your product may be obtained by contacting TESCO. TESCO will provide these by email, fax or mail. Your local TESCO representative can provide additional assistance. Be sure to have your complete model number ready.

Section 3: Installation

3.1 Introduction

50-4X Series pressure reducing regulators are specifically designed for extended life operation in high pressure hydraulic applications. The 50-4X Series is designed with an integrated bypass valve which controls large variations in flow rates at pressures up to 20,000 psig / 1379 bar. Applications include hydraulic power units for production, wellhead control panels (WHCP) and intervention work over control systems (IWOCS), where start-up requires high flow rates at large differentials and operate at high pressures with precise control.

3.2 Specifications

Maximum Inlet Pressure:

10,000, 15,000 and 20,000 psig / 690, 1034 and 1379 bar

Outlet Pressure:

9000-20,000, 8000-15,000, 6000-15,000, 4000-10,000, 2000-6000, 2000-4000, 1700-2500 psig
621-1379, 552-1034, 414-1034, 276-690, 138-414, 138-276, 117-172 bar

Operating Temperature:

-15°F to 165°F / -26°C to 73°C

Flow Capacity:

$C_v = 0.12$ (Control Regulator)
 $C_v = 1.9$ (Integrated Bypass)

Weight (approximate)*:

50-4000: 15 lbs / 6.8 kg
50-4100: 20 lbs / 9.1 kg
50-4200: 20 lbs / 9.1 kg

* Air loaded versions will have an additional approx. 10 lbs / 4.5 kg to account for the actuator.

3.3 Installation Diagram

Letter call-outs are referenced in the Installation and Start-Up Procedures section of this manual.

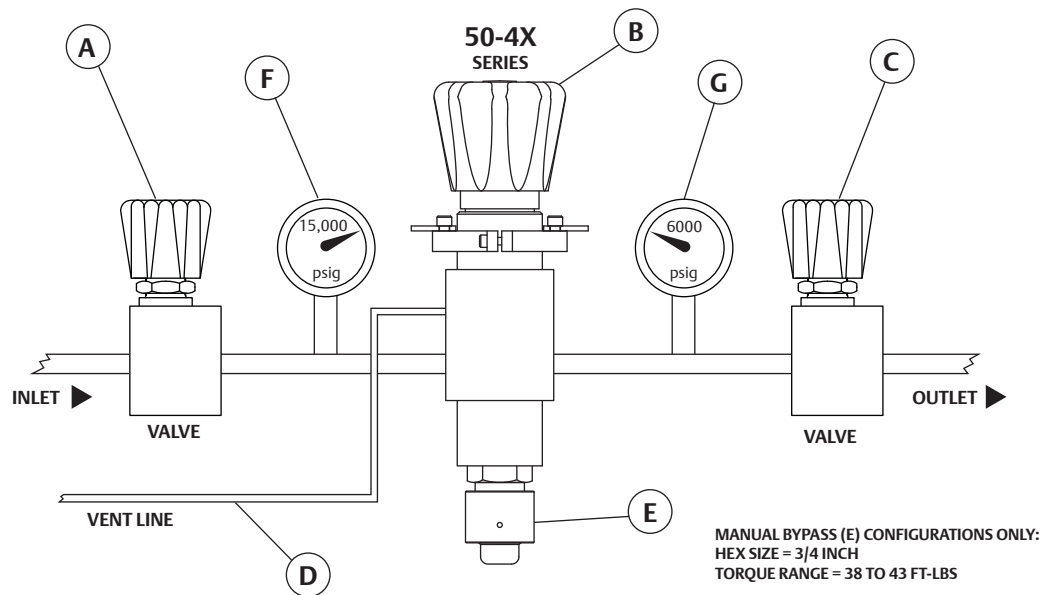

3.4 Installation

⚠ WARNING

Failure to follow these instructions or to properly install and maintain this equipment could result in an explosion, fire and/or chemical contamination causing property damage and personal injury or death.

TESCOM regulators must be installed, operated and maintained in accordance with federal, state and local codes, rules and regulations.

If the regulator vents gas or a leak develops in the system, service to the unit may be required. Failure to correct trouble could result in a hazardous condition.

Installation, operation and maintenance procedures performed by unqualified personnel may result in improper adjustment and unsafe operation. Either condition may result in equipment damage or personal injury. Call qualified personnel when installing, operating and maintaining the 50-4X Series regulator.

⚠ WARNING

Metering valves should not be used to isolate the pressure reducing regulator. It is strongly recommended that block and bleed valves be used to properly isolate the regulator from the rest of the system. Failure to do so could result in personal injury, equipment damage or leakage due to escaping fluid.

Confirm with gauges that there is zero pressure in the system prior to installation:

Note: Refer to the Installation Diagram for additional information.

1. Confirm both the inlet (A) and outlet (C) block and bleed valves are closed prior to installation.
2. Install the regulator with inlet port connected to the supply or inlet piping of the system and connect the outlet port to the downstream piping in the system.
3. Connect the vent port of the regulator to the vent line (D) (return line to reservoir). There should be no restrictions in the vent line between the regulator and reservoir that would allow for the buildup of pressure. Check valves should be used in the vent line if it is possible for pressure to be introduced by another section of the system.
4. Confirm all pipe fittings are torqued to manufacturer's recommended rating.

⚠ WARNING

Personal injury, equipment damage or leakage due to escaping accumulated fluid or bursting of pressure-containing parts may result if this regulator is:

- **Over-pressured**
- **Used with incompatible process fluid**
- **Installed where service conditions could exceed the limits given in the specifications section and marked on the regulator itself.**
- **Where conditions exceed any ratings of adjacent piping or piping connections. To avoid such injury or damage, provide pressure-relieving or pressure-limiting devices to prevent service conditions from exceeding those limits.**

Section 4: Start-up Procedure

⚠ WARNING

To avoid possible personal injury, equipment damage or leakage due to escaping fluid, make certain the regulator is installed as instructed in the Installation section. Pressure gauges must always be used to monitor downstream pressure during Start-up.

Note: For airload units follow the same process except instead of adjusting the handknob adjust the pressure on the airloader appropriately.

Note: Refer to the Installation Diagram for additional information. Page 8.

1. Prior to opening the supply block valve (A), rotate the hand knob of the regulator (B) clockwise until it stops turning. This will verify the regulator (B) is set at its maximum setpoint.
2. Leave the inlet (A) and outlet (C) block and bleed valves surrounding the regulator closed and pressurize the supply/inlet side of the system.
3. Slowly open the inlet block valve (A) to apply pressure to the inlet of the 50-4X Series regulator (B).
4. Verify the regulator's supply pressure (F).
5. Verify the regulator's outlet pressure (G) is stable. If there is steady leakage, remove regulator for inspection and repair.
6. Check the vent line (D) for any sign of steady leakage. If leakage occurs remove regulator for inspection and repair.
7. Turn the hand knob of the regulator (B) counterclockwise to decrease outlet pressure to below the desired outlet pressure setting, making sure not to go below the bypass operating range. Pressure will be vented off through the vent return line (D) as the pressure setting is adjusted to a lower setpoint. Reference product data sheet for bypass operating range.
8. Turn the hand knob clockwise to increase outlet pressure to the desired outlet pressure setting.
9. Verify pressure is stable (G) (not increasing or decreasing).
10. Fully open outlet valve (C) to fill downstream volume.

Note: If the desired control pressure is below the minimum of the regulator outlet pressure range, the manual bypass version is required and it must be set in the deactivated position.

To deactivate the bypass valve (E), first remove all pressure from the inlet and outlet of the regulator. Then remove the protective cover on the manual override bypass cap and turn the external 3/4 inch hex clockwise until a torque of 38 to 43 ft-lbs is reached. At this point the bypass valve is now deactivated and only the control regulator is in operation. When adjusting the control regulator outlet setpoint be aware pressure will be vented off as regulator's outlet pressure setting is adjusted in the decreasing direction.

The specified operating range of the bypass valve while active can be referenced on the product data sheet.

Activated and Deactivated Bypass Valves

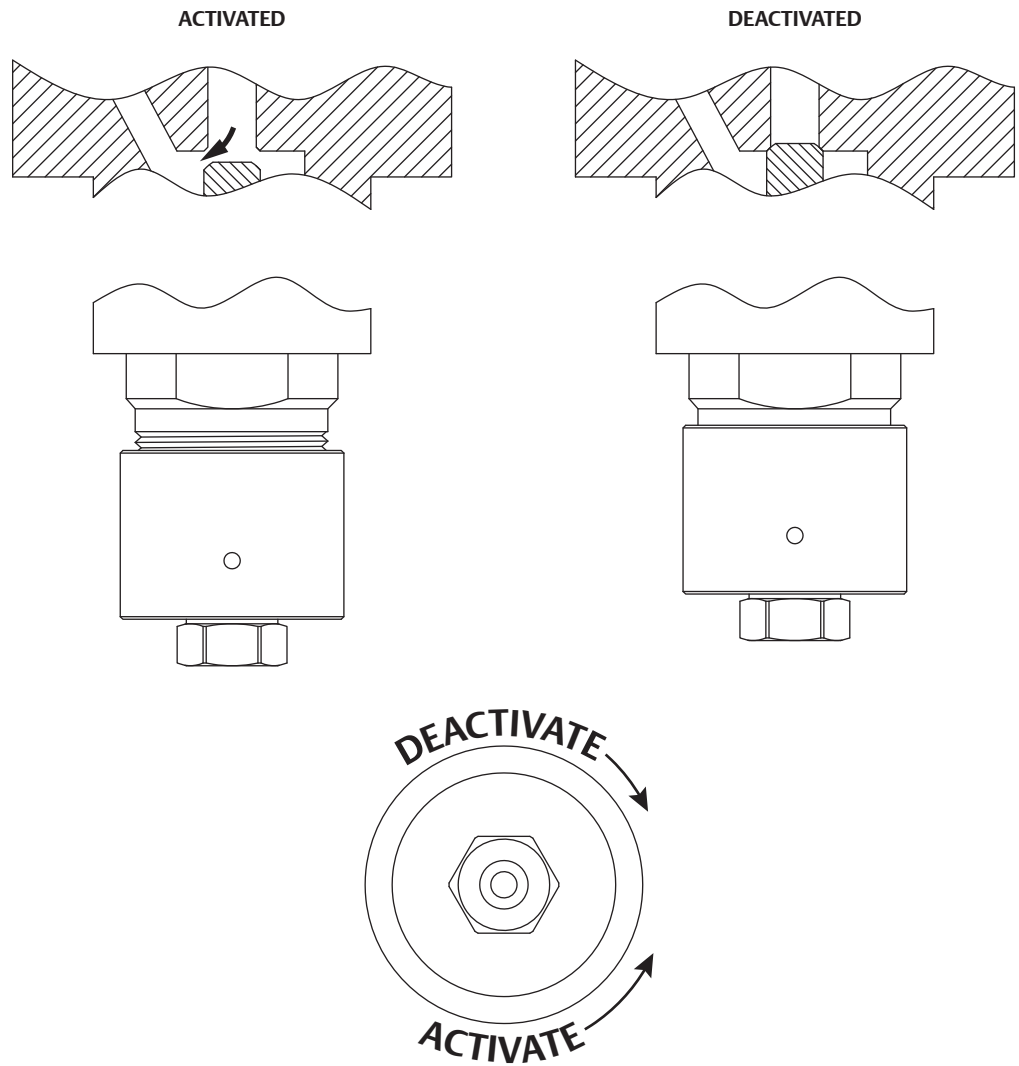

 Webadmin.Regulators@emerson.com

 Tescom.com

 Facebook.com/EmersonAutomationSolutions

 LinkedIn.com/company/emerson-automation-solutions

 Twitter.com/emr_automation

Emerson Automation Solutions

Americas

Elk River, Minnesota 55330 USA
T +1 800 447 1250
+1 763 241 3238

Europe

Selmsdorf 23923, Germany
T +49 38823 31 0

Asia Pacific

Singapore 128461, Singapore
T +65 6770 8337

Middle East and Africa

Dubai, United Arab Emirates
T +971 4 811 8100

DOPSM2091X012 © 2015, 2018 Emerson Process Management Regulator Technologies, Inc. All rights reserved. 01/18.

The Emerson logo is a trademark and service mark of Emerson Electric Co. All other marks are the property of their prospective owners. TESCOM™ is a mark owned by Tescom Corporation, a business of Emerson Automation Solutions.

The contents of this publication are presented for information purposes only, and while effort has been made to ensure their accuracy, they are not to be construed as warranties or guarantees, express or implied, regarding the products or services described herein or their use or applicability. All sales are governed by our terms and conditions, which are available on request. We reserve the right to modify or improve the designs or specifications of our products at any time without notice.

