

STOP DAMAGING ROOF-ICE BUILDUP

PRODUCT SELECTION GUIDE

Catalog Number	Length ft (m)	Watts	Bags of Roof Clips Included
ADKS100	20 (6)	100	1
ADKS150	30 (9)	150	1
ADKS300	60 (18)	300	2
ADKS400	80 (24)	400	3
ADKS500	100 (31)	500	4
ADKS600	120 (37)	600	4
ADKS800	160 (49)	800	5
ADKS1000	200 (61)	1000	7
ADKS1200	240 (73)	1200	8

MEASURE

- Horizontal length of each roof section to be protected, in feet _____
- Depth of overhang for each roof section, in inches _____
- Each dormer — up, over and down — per diagram, in feet _____
- Length of each downspout, in feet _____
- Note number of roof intersection valleys _____

CALCULATION BY SECTION

- For each section overhang depth, find the multiplier table _____
- If the section has no gutter, subtract 1.0 from the multiplier _____
- Multiply length of each roof section by its overhang multiplier _____
- Total all the section dormer measurements _____
- For each downspout with cable running down and back up, typically all but the last one on a cable run, multiply length by 2 and add together _____
- Total length of downspouts with cables running down only, typically the last one in a cable run _____
- Multiply the number of valleys by 6 _____

TOTAL ITEMS C-G

CONTROL YOUR ROOF AND GUTTER DE-ICING SYSTEM



The Roof Sentry RS2 unit automatically controls operation of ADKS electric roof de-icing cables. It measures both temperature and moisture to turn the system on or off in response to changing weather conditions.

EasyHeat™ is dedicated to keeping your surroundings safer, comfortable and more productive. Since 1951, the EasyHeat brand has delivered the largest family of high-performance products that efficiently deliver heat in residential and commercial applications.

From melting ice on roofs to keeping pipes from freezing, from de-icing sidewalks to warming kitchen floors, EasyHeat products have earned the trust and satisfaction of residential, commercial and industrial customers alike.

For more information, visit www.easyheat.com.
Customer Service (Press 1) and
Technical Support (Press 2): 1-800-621-1506



40400-001 Rev. 9

Appleton Grp LLC d/b/a Appleton Group. The EasyHeat and Emerson logos are registered in the U.S. Patent and Trademark Office. EasyHeat, Inc. is a wholly owned subsidiary of Appleton Grp LLC. All other product or service names are the property of their registered owners.
© 2021, Appleton Grp LLC. All rights reserved.

EASYHEAT®

EXPECT IT. PROTECT IT.

ADKS Series Electric Roof De-icing Cable

Prevent Roof Damage & Leaking
Keep Gutters & Downspouts Flowing
Pre assembled Ready-To-Install



KEEP GUTTERS AND DOWNSPOUTS FLOWING ALL WINTER LONG

ADKS roof and gutter de-icing cables help end costly ice damage by preventing ice dam formation and promoting the free flow of water through gutters and downspouts to ground level. This product is for the sole intended use of preventing ice dams from forming on inclined roofs with tab shingles, in gutters and in downspouts. This roof de-icing cable is not intended for use as a snow-melting system to clear roof of ice and snow. **Never install on a flat roof. Never install on combustible materials. Not suitable for use on metal roofs; contact EasyHeat for appropriate cable solutions.**



DESIGNING A SYSTEM

- Sun exposure, prevailing weather direction and roof shape may result in different conditions at different points on a roof. Several controls and shorter cable runs may be appropriate. If only one control is used, it should be located to respond to the worst icing conditions.
- The length of roofline alone does not determine cables/controls needed. Consider: roof design and size; gutter and downspout location; number of sides of a typical, peaked roof to be protected.
- Use of a temperature and moisture sensing control, such as the EasyHeat RS-2 Roof Sentry, is highly recommended. Using a proper control will ensure the system is automatically energized only when needed. Use one RS-2 for each ADKS cable installed.
- Use a ground fault protection device or outlet.
- Weather-proofed outlets of sufficient quantity and amp rating are required within six (6) foot cord-set length of the cable/control starting point.

Cable Installation Patterns

One cable may cover both roof and gutter areas, or separate cables can be used.

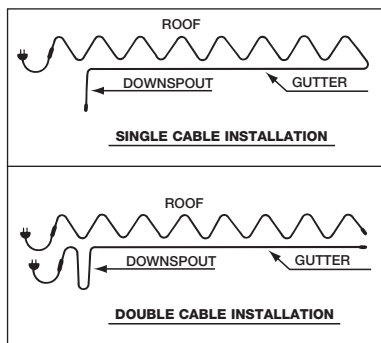

DETERMINE ROOF DE-ICING CABLE NEED MEASURE ROOF OVERHANG

Install cable over unheated portion of roof — normally roof area above overhang. This helps to ensure that water flowing onto the unheated roof area will be able to flow to the ground. Installing cable in valleys, gutter and downspouts as well creates an ice-free pathway for water to drain completely from eaves and gutter. For your de-icing cable requirements, determine the roof overhang (E in figure 1) with corresponding multiplier as follows:

Overhang Multiplier

Roof Overhang in (cm)	Multiplier For roof with gutter	Multiplier For roof without gutter
Less than 12 (30)	4.0	3.0
12 (30)	4.0	3.0
24 (60)	5.3	4.3
36 (90)	6.8	5.8
48 (120)	8.1	7.1
60 (150)	9.6	8.6
72 (180)	11.2	10.2

Note: For overhangs not listed, estimate multiplier. For example, for an 18 in (45.7 cm) overhang with a gutter, multiplier will be about 4.7.

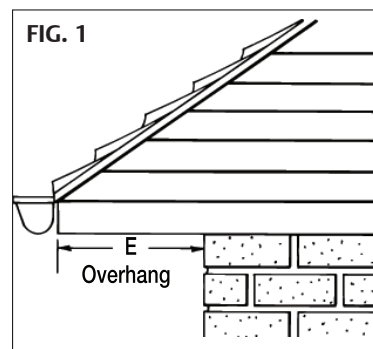

DETERMINE ROOF DE-ICING CABLE NEED MEASURE LENGTH OF ROOF

- 1 Measure horizontal roof length to be covered by cable; multiply by Overhang Multiplier to determine total cable length for roof area.
- 2 Add cable for downspout (A in figure 2). NOTE: if a downspout is located anywhere *other than* at the end of the cable routing, that downspout will require double length of cable (B in figure 2).
- 3 Add extra cable for valleys (6' per valley, C in figure 2) and around dormers (D in figure 2).

Example: 24 feet of roof, 24 inches overhang (therefore using Overhang Multiplier of 5.3), 2 downspouts at 10', one at end of cable run, and one at midrun, 1 valley, 1 dormer with 30' perimeter.

Cable length = $(24 \times 5.3) + 10 + 20 + 6 + 30 = 193.2$ feet
In this example, select **ADKS-1000 (200')**, as it is closest to 193.2 feet. Use excess cable in valley or downspout.

Compare your total to standard lengths available from your retailer. Specify closest product possible to your total need. **De-icing cable cannot be cut or altered; doing so voids the warranty.** Once cut, it cannot be repaired.

