

## 60T Series

### ***Snap-Action Temperature Controls***



#### ***Snap-Action Temperature Control***

The 60T line of 3/4" (19mm) bimetal disc temperature controls from Therm-O-Disc offers proven reliability in a versatile, cost-effective design. The snap-action of the temperature sensing bimetal disc provides high-speed contact separation, resulting in exceptional life characteristics at electrical loads up to 25 amps at 240VAC. A wide variety of terminal and mounting configurations are available for maximum design flexibility. This unsurpassed flexibility and time proven reliability, at an affordable price, has made the Therm-O-Disc 60T the most popular and widely applied temperature control in the major appliance and heating/air conditioning industries.

#### ***Additional Features and Benefits***

Additional features and benefits of the 60T include:

- Available with automatic and manual reset SPST (Single Pole, Single Throw) or automatic reset SPDT (Single Pole, Double Throw) switch configurations.
- Welded construction for integrity of current-carrying components.
- Available with an exposed or enclosed bimetal disc for either increased thermal response or protection from airborne contaminants.

#### ***Switch Actions and Typical Applications***

The 60T is available in three switch actions:

- Automatic Reset SPST
- Automatic Reset SPDT
- Manual Reset SPST (Trip Free)

Automatic Reset SPST – In this design, the switch can be built to either open or close its electrical contacts on temperature rise. Once the temperature of the bimetal disc has returned to a specified reset temperature, the contacts will automatically return to their original state. Typical uses of this construction include limiting and regulating temperatures in clothes dryers and heating/air conditioning systems (see figures 1 and 2).

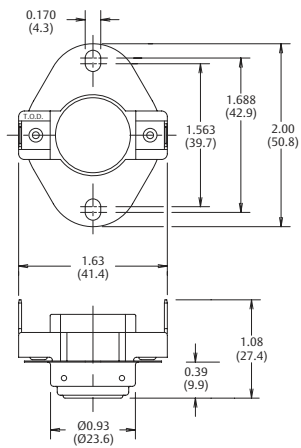

**Airstream Mounting**

Figure 1

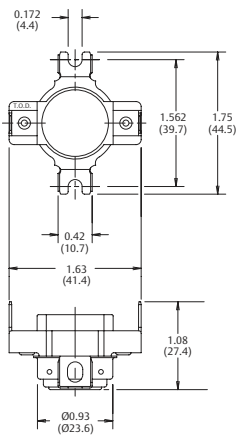

**Surface Mounting**

Figure 2

*Dimensions are shown in inches and (millimeters).*



Automatic Reset SPDT – This design is the same as the SPST described above with the addition of an auxiliary contact which makes circuit upon the opening of the main contacts and breaks circuit when the main contacts reset. Refer to the “General Electrical Ratings” chart for rating limitations on the auxiliary contacts. Typical uses of this construction include fan speed changeover at a specified temperature and lighting of an indicator lamp when an abnormal temperature condition has been reached (see figure 3).

**CAUTION . . . When designing a circuit for a single pole, double throw control, an electrical load must be applied to terminal number 2 and/or 3 to avoid a possible short circuit condition.**



**SPDT Automatic Reset – Airstream Mounting**

Figure 3



Manual Reset SPST – This design is available only with electrical contacts which open on temperature rise. The contacts may be manually reset after the control has cooled below the open temperature calibration. This construction is classified as “M2 Trip Free” by the approval agencies. A patented design holds the contact open in the event the reset button is held in the depressed position in an attempt to defeat the manual reset function of the thermostat. Typical uses include any temperature limiting application where operation of the thermostat should result in the user or service personnel having to attend the unit (*see figure 4*).

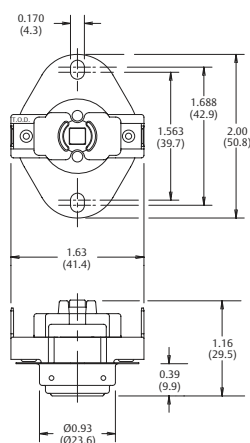

**SPST Manual Reset – Airstream Mounting**

Figure 4

*Dimensions are shown in inches and (millimeters).*

## **Thermal Response**

An exposed or enclosed bimetal disc may be specified with any of the airstream or surface mounting configurations. The enclosed disc construction provides greater protection than the exposed disc construction, keeping airborne contaminants such as dirt and dust from entering the control. It also protects the bimetal disc from possible physical damage during assembly and in the final application. In applications where faster response to radiant heat is required, an exposed bimetal disc or an optional black oxide mounting finish may be specified.

## Mounting Configurations

The 60T is available in an airstream or a surface mount configuration:

**Airstream Mounting** – This mounting configuration positions the bimetal disc through a hole in the mounting surface to sense temperature within an enclosure such as a heater box or air duct. The standard configuration (see figure 1) positions the bimetal disc .39” (9.9mm) into the airstream while an optional version (see figure 5) positions the bimetal disc .78” (19.8mm) into the airstream. Airstream configurations may be specified with a flange (see figure 5) or without a flange (see figure 6) to suit specific application needs.

**Surface Mounting** – This optional mounting configuration positions the bimetal disc firmly against the mounting surface to sense the actual mounting surface temperature (see figure 2).

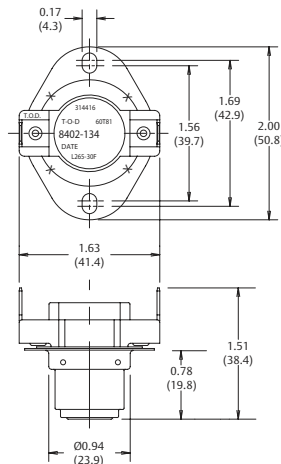

### SPST Airstream Mounting – Deep Disc Cup

Figure 5

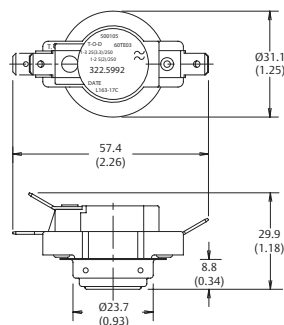

### SPDT Airstream – No Flange

Figure 6

Dimensions are shown in inches and (millimeters).

## Terminal Configurations

Standard Terminals – Standard terminations for the 60T are .250" x .032" (6.3 x .8mm) tin-plated brass blade terminals formed at 90 angular degrees to the thermostat mounting surface. Terminal angles of 0 and 30 degrees can also be provided (*see figure 7*).

### Blade Terminal Angles



Figure 7

Non-Standard Terminals – The 60T can also be provided with a variety of optional terminals. Some of the more common variations include .188" (4.8mm) blade terminals, 8-32 screw terminals and fork terminals. Unique variations such as double or offset blade terminals are also available.

Terminal Orientation – For added flexibility, the orientation of the terminals with respect to the mounting bracket can be specified in 45 angular degree increments (*see figure 8*).

### Terminal to Mounting Bracket Orientation



*Terminals 90° to mounting holes (standard)*



*Terminals 45° clockwise to mounting holes*



*Terminals 45° counterclockwise to mounting holes*

Figure 8



## Calibration Temperatures, Differentials and Tolerances

To use the calibration chart, locate the range in the left hand column, in which the highest calibration set point (open or close) falls. Then, locate across the top, the range in which the nominal differential falls. The standard open and close set point tolerances are shown where the two columns converge. The chart also indicates what differentials are available in each of the calibration set point ranges. Tighter open and close tolerances are available at added cost. Thermocouple samples can be provided to assist in determining the appropriate calibration temperature for specific application. For more information on tightened tolerances or availability of differentials not listed in the chart, please consult one of our sales engineers.

## Calibration Temperatures, Differentials and Standard Tolerance of the 60T Series

Highest Calibration Set Point Range (Open or Close)	Nominal Differentials (temperature difference between nominal open and close set point)													
	10-14°F 5.5-8°C		15-19°F 8.5-10.5°C		20-29°F 11-16°C		30-39°F 16.5-21.5°C		40-49°F 22-33°C		50-80°F 33.5-44.5°C		Manual 34-44.5°C	
	Open	Close	Open	Close	Open	Close	Open	Close	Open	Close	Open	Close	Open	Close
0°-79°F -18°-26°C	±6 ±3.5	±6 ±3.5	±6 ±3.5	±6 ±3.5	±6 ±3.5	±6 ±3.5	±6 ±3.5	±7 ±4	±6 ±3.5	±8 ±4.5	±7 ±4	±8 ±4.5	-	-
80°-200°F 28°-93°C	±5 ±3	±5 ±3	±5 ±3	±5 ±3	±5 ±3	±5 ±3	±5 ±3	±6 ±3.5	±5 ±3	±7 ±4	±6 ±3.5	±8 ±4.5	±8 ±4.5	<-31 <-35
201°-250°F 94°-121°C	-	-	±5 ±3	±6 ±3.5	±5 ±3	±6 ±3.5	±5 ±3	±7 ±4	±6 ±3.5	±8 ±4.5	±7 ±4	±9 ±5	±7 ±4	<-31 <-35
251°-300°F 122°-149°C	-	-	-	-	±6 ±3.5	±8 ±4.5	±6 ±3.5	±8.5 ±4.5	±7 ±4	±10 ±5.5	±8 ±4.5	±11 ±6	±8 ±4.5	<-31 <-35
301°-350°F 150°-177°C	-	-	-	-	±7 ±4	±9 ±5	±7 ±4	±10 ±5.5	±8 ±4.5	±12 ±6.5	±9 ±5	±13 ±7	±9 ±5	<-31 <-35

NOTE: Tighter tolerances and/or differentials than those listed in the chart are also available. Please consult a Therm-O-Disc sales engineer for assistance.



## General Electrical Ratings

The 60T series of controls has been rated by major agencies throughout the world. The agency ratings can be used as a guide when evaluating specific applications. However, the mechanical, electrical, thermal and environmental conditions to which a control may be exposed in an application may differ significantly from agency test conditions. Therefore, the user must not rely solely on agency ratings, but must perform adequate testing of the product to confirm that the control selected will operate as intended in the user's application.

Ratings for 100,000 cycles\*, maximum temperature 350°F (175°C)

Thermostat Type	Contact Arrangement	Inductive Amperes		Pilot duty VA	Resistive Amperes	Volts AC	Agency Recognition
		FLA	LRA				
60T, 60TX**	Contacts 1 & 3 SPST or SPDT	10	60	480	25	120	UL E19279 MH5304
		5	30	480	25	240	
		—	—	125	12.5	277-480	
		14	72	—	—	120	
		10	60	—	—	240	
	5	30	—	—	480		
Contacts 1 & 2 SPDT	—	—	125	—	120-277		
	5.8	34.8	—	—	120		
	2.9	17.4	—	—	240		
60T, 60TX**	Contacts 1 & 3 SPST or SPDT	10	60	125	25	120	CSA LR10281 LR19988
		5	30	125	25	240	
		2	12	400	10	600	
	—	—	125	—	240-480		
Contacts 1 & 2 SPDT	—	—	125	—	120-277		
60T, 60TX 60TE, 60TXE**	Contacts 1 & 3 SPST or SPDT	3.3	—	—	25	250	Global Agencies*** VDE104130 BEAB CAT 0636 Cert C1155N
		3.3	—	—	16	400	
		—	—	—	45	250	
	Contacts 1 & 2 SPDT	2.0	—	—	5	250	
	Contacts 1 & 3 MR	3.3	—	—	25	250	
—	—	—	37.5	250			

\* These are consolidated ratings some of which are limited to 30,000 cycles. At thermostat end-of-life, the contacts may remain permanently closed or open. For complete and current ratings, please contact our Sales Engineering Department.

\*\* The 60TX has electrical clearances of 1/4-inch through air and 3/8-inch over surface which may be required for some heating and air conditioning applications. Overall physical dimensions are the same as the 60T.

\*\*\* Global agencies include O.V.E. (Austria), B.S.I. (United Kingdom), DEMKO (Denmark), UTE (France), VDE (Germany), KEMA (Netherlands), NEMKO (Norway), SEV (Switzerland) and SEMKO (Sweden).





## Product Numbering System

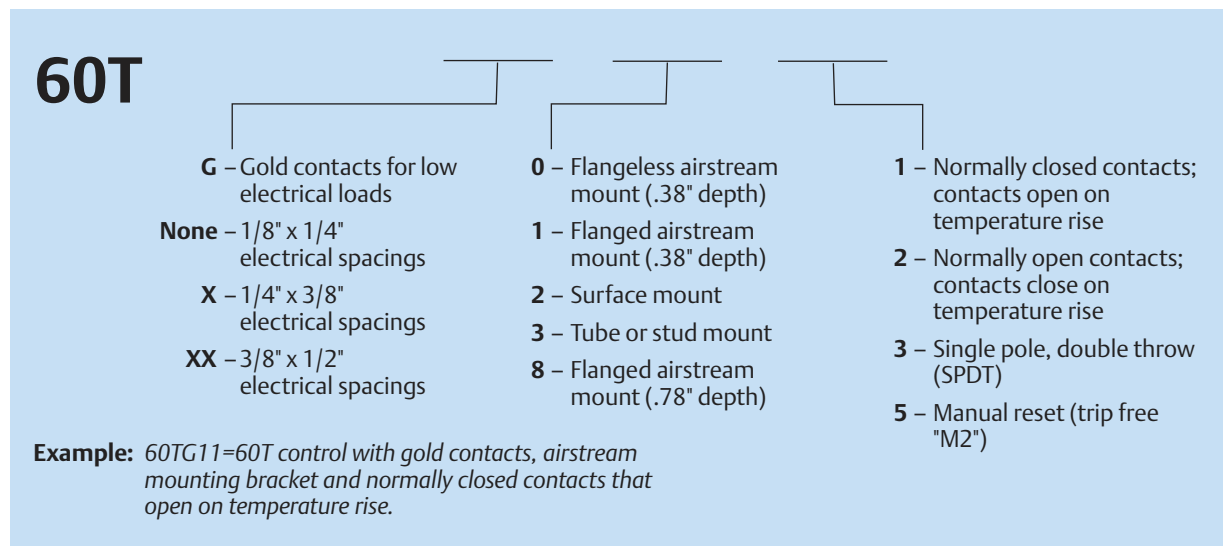

### Important Notice

Users must determine the suitability of the control for their application, including the level of reliability required, and are solely responsible for the function of the end-use product.

These controls contain exposed electrical components and are not intended to withstand exposure to water or other environmental contaminants which can compromise insulating components. Such exposure may result in insulation breakdown and accompanying localized electrical heating.

A control may remain permanently closed or open as a result of exposure to excessive mechanical, electrical, thermal or environmental conditions or at normal end-of-life. If failure of the control to operate could result in personal injury or property damage, the user should incorporate supplemental system control features to achieve the desired level of reliability and safety. For example, backup controls have been incorporated in a number of applications for this reason.