

# Rosemount 5900S Still-pipe Array Antenna Insert Pipe

## Benefits

- Fits any floating roof tank with an existing 8-in. (or larger) gauge still-pipe
- Provides for temperature, level measurement and water level in an existing still-pipe
- The gauge can be provided with a hinged array antenna allowing for full access to the insert pipe for hand dipping, sampling, etc.
- Reduce emissions
- Can be installed without taking the tank out of service
- Measure with highest precision non-contact radar



The Rosemount 5900S with array antenna is a premium non-contact radar level gauge for still-pipe measurement. Typical applications are crude oil tanks with floating roofs and gasoline/product tanks with or without floating roofs. Most of these tanks are equipped with a standard 8-in. still-pipe. This means adding a multi point temperature probe with water level sensor is not possible without extensive modification to the tank. Using the insert pipe allows for the addition of these auxiliary measurement devices without modifying the tank or taking it out of service. When coupled with the hinged array antenna, the insert pipe allows full access to the tank for hand gauging, sampling, etc.

**Figure 1-1. Rosemount 5900s with Array Antenna Is Designed for Installation in New, Existing or Insert Still-pipes**

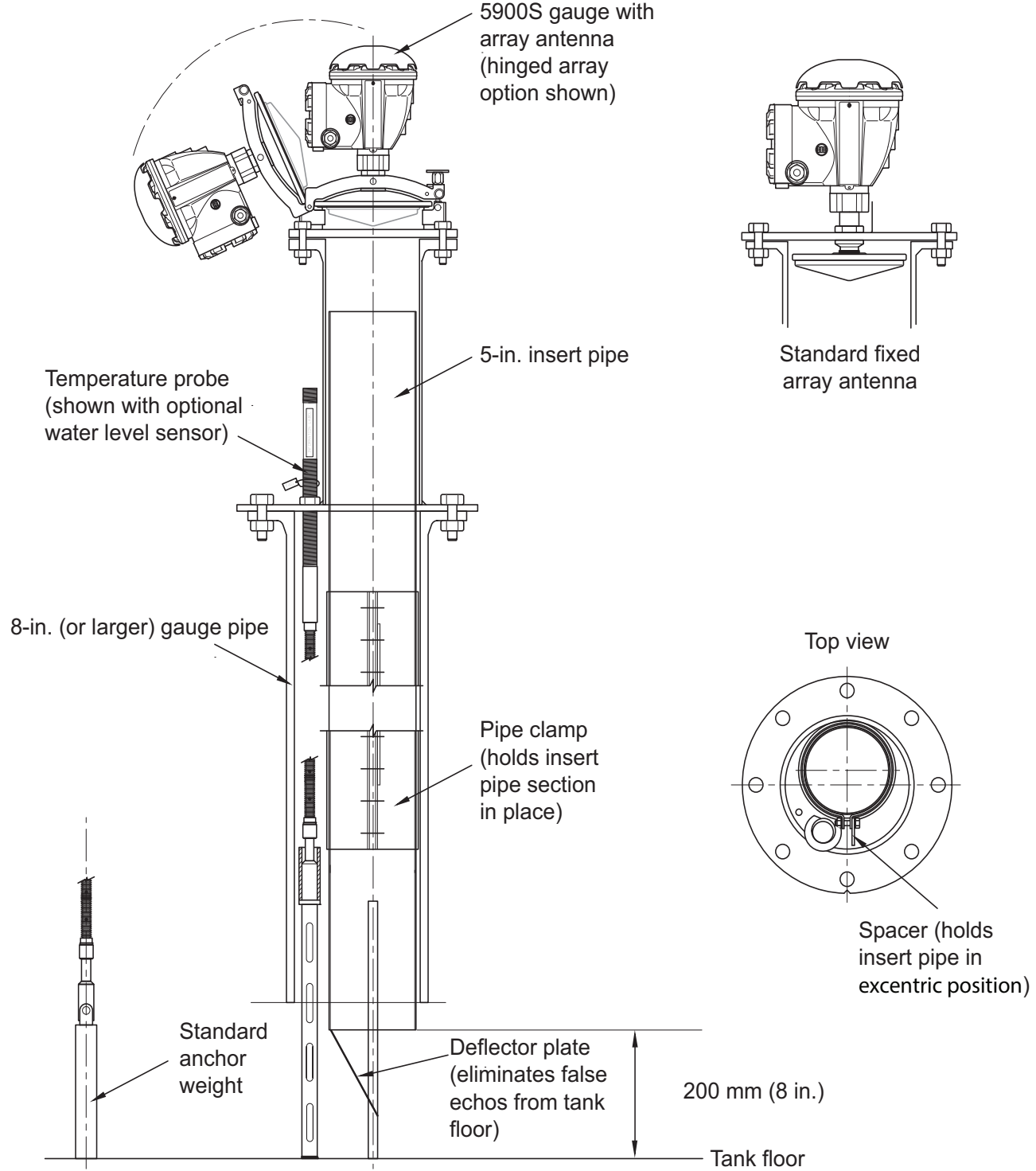

**Figure 1-2. Rosemount 5900s with Array Antenna, Hinged Hatch Version**



Specifications for Rosemount 5900S Still-pipe insert pipe	
<b>Standard lengths</b>	15 meters (49 feet)
	18 meters (59 feet)
	21 meters (68 feet)
	24 meters (78 feet)
<b>Material of construction</b>	316 Stainless steel

Figure 1-3. Installation Overview



*The Emerson logo is a trade mark and service mark of Emerson Electric Co.  
Rosemount and the Rosemount logotype are registered trademarks of Rosemount Inc.  
PlantWeb is a registered trademark of one of the Emerson Process Management group of companies.  
HART and WirelessHART are registered trademarks of the HART Communication Foundation  
All other marks are the property of their respective owners.*

© 2015 Rosemount Tank Radar AB. All rights reserved.

**Emerson Process Management  
Rosemount Tank Gauging**  
Box 130 45  
SE-402 51 Göteborg  
SWEDEN  
Tel: +46 31 337 00 00  
Fax: +46 31 25 30 22  
E-mail: sales.rtg@emerson.com  
[www.rosemount-tg.com](http://www.rosemount-tg.com)

**Emerson Process Management  
Rosemount Tank Gauging North America  
Inc.**  
6005 Rogerdale Road  
Mail Stop NC 136  
77072 TX Houston  
United States  
Primary Phone: +1 281 988 4000  
Secondary Phone: +1 800 722 2865  
E-mail: sales.rtg.hou@emerson.com

**Emerson Process Management  
Latin America**  
1300 Concord Terrace, Suite 400  
Sunrise Florida 33323  
United States  
Tel: + 1 954 846 5030

**Emerson Process Management  
Rosemount Tank Gauging Middle  
East & Africa.**  
P. O Box 20048  
Manama  
Bahrain  
Tel: +973 1722 6610  
Fax: +973 1722 7771  
E-mail: rtgmea.sales@emerson.com

**Emerson Process Management  
Asia Pacific Pte Ltd**  
1 Pandan Crescent  
SINGAPORE 128461  
Tel: +65 6777 8211  
Fax: +65 6777 0947  
E-mail: specialist-itg.rmt-ap@ap.emersonprocess.com

**ROSEMOUNT**

  
**EMERSON**  
Process Management