

## Bettis TEC2 Electric Actuator with Model 500 Intelligence Made Simple (Model 500 Discontinued)

For over 50 years, Emerson Valve Automations electric actuators have provided the process world with a customer-proven, reliable electric actuator control platform. BETTIS actuators are used in virtually every application where valves are operated automatically. Emerson's electric brand, established in 1949, has pioneered the industry with innovation and technical performance. BETTIS actuators and controls have a myriad of applications and can be found in virtually every part of the energy and hydrocarbon processing industries – oil and gas, power, refining chemical and petrochemical. Customers also rely on BETTIS actuators and controls for their established track record for outstanding performance in water/wastewater, food and beverage, pulp and paper, and marine applications. The new TEC2 actuator controls product brings to market the next generation of innovative smart controls; flexible technology solutions that cover all your automation needs, from high-duty cycle, low-torque applications to bigger valves requiring higher-torque capability.

In addition to an innovative control platform, TEC2 extends the mechanical Series 2000 to include Model 500 (Model 500 Discontinued), the latest smaller and lightweight multi-turn actuator frame size designed to meet application needs requiring lower torque ranges.



## Table of Contents

<b>Section 1:</b>	<b>TEC2 Series Key Benefits and Features .....</b>	<b>3</b>
<b>Section 2:</b>	<b>TEC2 Series Model Options, Modules and Specification.....</b>	<b>5</b>
	<i>Model Options .....</i>	<i>5</i>
	<i>Standard Modules .....</i>	<i>5</i>
	<i>Optional Modules .....</i>	<i>6</i>
	<i>General Specification .....</i>	<i>6</i>
<b>Section 3:</b>	<b>Environmental Ratings and Certifications .....</b>	<b>7</b>
<b>Section 4:</b>	<b>Performance Data .....</b>	<b>9</b>
<b>Section 5:</b>	<b>Model 500 Number Codes and Selection Standard (Model 500 Discontinued).....</b>	<b>10</b>
<b>Section 6:</b>	<b>TEC2 Wiring Diagrams .....</b>	<b>11</b>
<b>Section 7:</b>	<b>Model 500 Wiring Diagrams (Model 500 Discontinued) .....</b>	<b>13</b>
<b>Section 8:</b>	<b>Model 500 Drawings (Model 500 Discontinued) .....</b>	<b>15</b>

## TEC2 Series Key Benefits and Features

### Improved Asset Productivity and Operational Efficiency

- Advanced diagnostics capability and predictive analytics through DCMLink software platform.
- DCMLink integration path - DeltaV, Emerson PlantWeb solution.
- Partial and Full-Stroke tests with torque trending diagnostics.
- Absolute position detector with 0.002% full-stroke resolution. Requires no battery, provides consistent and accurate position feedback—with no loss of calibration during power failures.
- Encoder based torque switch with 1% of torque resolution in each direction.
- Enhanced monitoring, recording, alarm capability.
- TEC2 available with Model 500 – Smallest, lightest multi-turn actuator frame size. (Model 500 Discontinued)
- Broad range of digital networking and analog control options.
- Wireless Bluetooth capability.

### Rugged Reliability and Operational Safety

- Non-intrusive design. Rugged ductile iron gear housing is shock and vibration-resistant.
- Non-penetrating, vibration-resistant Hall Effect switches enable setup without opening control compartments.
- Emergency shutdown.
- Corrosion resistant, 316 stainless steel fasteners throughout.
- Double sealed terminal chamber allows installation wiring to be performed without exposing control components to hazardous environments.
- Optional battery backup allows LCD to remain powered during electrical outages; no battery required to maintain any data or position calibration.
- Space heater prevents internal condensation (thermostatically controlled; turns off at 105°F (40°C)).
- Patented remote module for safe calibration and monitoring from safe and convenient location.
- Improved product reliability through complexity reduction of electrical components .
- Explosion-proof and weather-proof capability. Control enclosure is made of low-copper aluminium alloy, powder-coated, salt-resistant, and certified by F.M., C.S.A., Cenelec, and TSA for all gas groups in explosion-proof environments. Also rated for IP68 submersible service.
- Coating options for corrosive and fire-proof protection.

## TEC2 Series Key Benefits and Features (continuation)

### Ease of Use

- New and improved graphical interface with polarized glass for better visibility. 37% larger, adjustable contrast LCD display.
- Multi-Language support.
- The industry's most convenient declutch lever can be locked out with a padlock in either Hand or Motor position.
- Twin access ports give users the freedom to easily access internal components.
- Improved serviceability – Record over 4800 events and monitor over 60 actuator functions.
- Convenient, multiple-mounting configurations for local display module allows for easy access and ease of use.
- Interoperable with existing TEC2000 installation base. Upgrade Conversion kit.
- Local and Remote monitoring.



REMOTE MODULE



LCD (CLOSE-UP)



DE-CLUTCH LEVER

## TEC2 Series Model Options, Modules and Specification

### Model Options

Series	Actuator Type	Torque Range	Mounting Options	Bus Options
TEC2	Quarter Turn	50 to 400,000 Ft-Lbs (68 to 542,300 Nm)	Direct-Mount, Side-Mounted	Modbus RTU DeviceNet FOUNDATION™ Fieldbus PROFIBUS HART Ethernet
	Multi-Turn	4 to 16,000 Ft-Lbs (6 to 21,693 Nm)	Direct-Mount, Side-Mounted	
	Multi-turn (Thrust)	1 to 1,056 KLbs (5 to 4,700 KN)	Direct-Mounted/ Rising Stem	

### Standard Modules

#### Absolute Position Detector – APD

- Patent Pending limit switch utilizing Hall-Effect sensors
- Impervious to grease and grime
- Supports up to 6144 drive sleeve revolutions
- 12-Bit accuracy
- 0.002% full-stroke resolution (typical)
- Mechanically coupled to worm drive of actuator
- Requires no battery backup

#### Torque Switch Module – TSM

- Proven encoder based Torque Switch
- 8-bit magnetic encoder coupled directly to torque pinion
- Torque resolution of 2% each direction
- LED indication for no-load on torque switch

#### Motor Control/Power Supply Module – MCM

- Model 500
  - Solid State Starter standard
  - Current limiting circuitry
  - Phase detect and auto correct
  - Power Supply Module - PSM  
(Model 500 Discontinued)
- TEC2 Larger actuators
  - Current production motor control modules

#### Input Output Module – IOM

- Separate field serviceable module (not part of CCM)
- 6 Discrete optically isolated inputs
  - Default settings defined for discrete service
  - Input ratings
    - 18 to 150 VDC or 20 to 250 VAC
- Discrete outputs RO#1 - RO#4
  - Four individually configurable SPST latching relays
  - Trigger on 1 of 28 different selectable events
    - NO, NC, Blinking
  - Default settings defined for discrete service
  - Relay ratings
    - 5 Amp at 30 VDC or 250 VAC Resistive
    - 2 Amp Inductive load
- Discrete output RO#5
  - SPST, (1) NO, (1) NC non-latching, monitor relay or network control
  - Relay ratings
    - 5 Amp at 30 VDC or 250 VAC Resistive
    - 2 Amp Inductive load

#### Separate Terminal Chamber – STC

- Double-sealed terminal chamber
  - Permits field wiring without exposing controls
  - Watertight seal between conduit and controls
  - Watertight/XP seal - terminals and atmosphere

## TEC2 Series Model Options, Modules and Specification (continuation)

- All external power and control wiring termination
    - 48-point terminal block
    - Pre-installed nickel-plated steel screws
    - Highly visible terminal labels
    - Includes Lexan HVC (High Voltage Cover)
  - 2 user accessible and replaceable primary fuses
  - Conduit Entries
    - Model 500 (fixed position)
      - 3 x 1" NPT bottom entry,
      - 1 x 0.5" NPT top entry
- (Model 500 Discontinued)*

### Optional Modules

#### Auxiliary Control Module – ACM

- Installed at factory or field upgrade
- One board for Futronic and Controlinc
- Analog I/O
  - Independently isolated
  - Loop powered (internal or external 24 Vdc)
  - Calibration per user standards
  - Futronic II and IV accuracy
    - Accuracy to 0.5% at 15 seconds operating time
    - Up to 1200 starts per hour
  - Model 500 is Futronic IV
- *(Model 500 Discontinued)*
- Two 4-20mA analog inputs
  - Modulating control (setpoint)
  - Network monitor and report
- Two 4-20mA analog outputs
  - Valve position/torque feedback
  - Valve setpoint
  - Network control

#### Auxiliary Relay Module – ARM

- Installed at factory or field upgrade
- Adds 4 latching individually configurable relays
  - Trigger on 1 of 28 different events
  - NO or NC or Flashing (Blinking)
- Compatible as standalone or with ACM
  - Used with Futronic
- Relay ratings
  - 5 Amp at 30 VDC Resistive
  - 5 Amp at 250 VAC Resistive
  - 2 Amp Inductive load

#### Communication Adapter Module – CAM

- Installed at factory or field upgrade
  - CAM201 Modbus (Bus connection)
  - CAM205 Modbus (E>Net)
  - CAM206 HART
  - CAM207 Devicenet
  - CAM209 Ethernet
  - CAM218 Foundation Fieldbus H1
  - CAM220 Profibus DPV1

#### Space Heater Module – SHM

- Mounted under auxiliary cover on TEC2
- Rated 12 watts and maintains -40 to +45°C

#### Display Backup Module – DBM

- Backup for display and discrete output
  - IOM Relays, Monitor Relay, ARM
- Shelf life 12 yrs, expected life 5 yrs, operational life 417 hrs (static)
- Mounted under auxiliary cover on TEC2
- Not required to maintain position and settings

#### Remote Display Module – RDM





- Maximum 2 RDMs per actuator
- Identical messages display at all modules
- Patented control algorithm for L-O-R
- Actuators can be set up remotely at any RDM
- Display cover lists agency approvals
- Communicates via RS485 from actuator to RDM
  - 1200 meters (4000 ft) max combined distance
- Power via 24VDC or 115/208/220/230 VAC, 50/60 Hz
  - RDM accepts any listed voltage (1 interface board)
  - Actuator can power 1 RDM at 24 Vdc

### General Specifications

#### Available Voltages

- 3 Phase, 60 Hz 208, 230, 380, 440, 460, 575, and 690
- 3 Phase, 50 Hz 220, 380, 415, and 460
- 1 Phase, 60 Hz 115, and 230
- 1 Phase, 50 Hz 115, and 230
- DC 12, 24, 48, and 125

## Environmental Ratings and Certifications

FM		Class I, II, III Division 1 Groups B,C,D,E,F,G T4 @ Ta 60°C, Type 4X, 6P (50 ft for 7 days) T4 @ Ta 60°C, Type 4X, 6P (50 ft for 7 days)
CSA		Class I, Groups B C & D, Class II Groups E,F,G, Class III T4 or T4A, Type 6P Class I, Groups D; T3C  RDM Class I, Groups B, C, D; Class II, Groups E,F,G; Class III; T6: Type 6P/4X  CBM Class I, Groups C and D; Class II, Groups E,F,G; Class III; T6; Type 6p/4X
ATEX		SIRA 03ATEX1510X  II 2 GD Ex d IIB T4 Gb Ex d IIB + H <sub>2</sub> T135°C Db IP68 Ex tb IIIC T135°C Db IP68 Ta -20°C to +60°C  The M8 fasteners used to secure each cover to the electronics enclosure and the RDM cover to the RDM enclosure are of property class (or 'grade') 8.8. The fasteners used to secure the motor enclosure to the electronics enclosure, the electronics enclosure to the gear box and the end caps to the motor frame are of property class (or 'grade') 5. Replacement fasteners shall meet these minimum values.  RDM  II 2 GD Ex d IIB +H <sub>2</sub> T6 Gb Ex tb IIIC T85°C Db 1P68 Ta -20°C to +60°C
IECEX		IECEX SIR 12.0035X Ex d IIB T4 Gb Ex d IIB + H <sub>2</sub> T135°C Db IP68 Ex tb IIIC T135°C Db IP68 Ta -20°C to +60°C  RDM  II 2 GD Ex d IIB +H <sub>2</sub> T6 Gb Ex tb IIIC T85°C Db 1P68
GOST	GOST	№POCC US.ГБ08.B00188 dtd 28.01.2013
InMetro		CEPEL 08.1640X  Ex d IIB T4 Gb IP68; Ta 60°C -20°C ≤ Tamb ≤ +60°C

## Environmental Ratings and Certifications (continuation)

<p>AWWA</p>	 <p>American Water Works Association Dedicated to the World's Most Important Resource™</p>	<p>ANSI/ AWWA C542-09 Standard</p>
<p>MIL-STD-167-1 (SHIPS)</p>		<p>MIL-STD-167-1 (SHIPS), Mechanical Vibrations of Shipboard Equipment (Type I – Environmental and Type II – Internally Excited)</p>
<p>MIL-S-901D (Navy)</p>		<p>MIL-S-901D (Navy), "Military Specification, Shock Tests, H.I. (High Impact); Shipboard Machinery</p>



## Performance Data

Model Series	Maximum Stem Size		Maximum Thrust		Maximum Torque		Output Speed (rpm)		Mounting Base	
	(inch)	(mm)	(lb)	(kN)	(ft-lb)	(Nm)	60 Hz	50 Hz	MSS	ISO
<b>Multi-Turn (Thrust and Torque)</b>										
500	1.57	40	9,000	40	125	170	12-192	10-160	FA 10	FA 10
1000	1.38	35	10,000	44	130	176	0-144	0-120	FA 10	FA 10
2000	2.25	57	30,000	133	410	555	0-144	0-120	FA 14	FA 14
3000	3.00	76	45,000	200	900	1,220	0-144	0-120	FA 16	FA 16
4000	3.50	89	75,000	334	1,400	1,900	0-144	0-120	FA 25	FA 25
5000	3.50	89	90,000	400	1,900	2,575	0-144	0-120	FA 30	FA 30
6000-1	3.50	89	116,000	516	3,000	4,100	0-48	0-40	FA 30	FA 30
6000-2	5.00	127	160,000	712	5,800	7,865	0-48	0-40	FA 36	FA 35
6000-3	4.50	114	196,000	872	5,800	7,865	0-48	0-40	FA 36	FA 35
7000	6.00	152	250,000	1,112	8,100	10,980	0-30	0-25	FA 40	FA 40
8000	6.00	152	335,000	1,490	15,000	20,340	0-18	0-15	FA 40	FA 40
9000	9.00	228	1,000,000	2,250	35,000	47,450	0-18	0-15	FA 48	FA 48
<b>Multi-Turn (Torque Only)</b>										
D	1.25	32	-	-	300	410	0-250	0-208	FA 10	FA 10
U	2.00	51	-	-	600	815	0-250	0-208	FA 14	FA 14
S	2.00	51	-	-	1,900	2,575	0-200	0-167	FA 16	FA 16
Model Series	Maximum Stem Size		Maximum Thrust		Maximum Torque		Operating Time (sec)		Mounting Base	
	(inch)	(mm)	(lb)	(kN)	(ft-lb)	(Nm)	60 Hz	50 Hz	MSS	ISO
<b>Part-Turn (90° Rotation)</b>										
P	1.13	29	-	-	210	285	15-60	18-72	FA 10	FA 10
Q	2.00	51	-	-	750	1,020	5-120	6-144	FA 12	FA 12
R	3.25	82	-	-	1,500	2,035	15-360	18-432	FA 16	FA 16
M/MG02	3.25	82	-	-	2,500	3,390	10-360	12-432	FA 16	FA 16
M/MG03A	4.00	101	-	-	5,000	6,780	10-600	12-720	FA 30	FA 30
M/MG03B	5.00	127	-	-	7,500	10,170	10-600	12-720	FA 30	FA 30
M/MG05	6.00	152	-	-	15,000	20,340	15-900	18-720	FA 40	FA 40
W/MG05	7.00	178	-	-	30,000	40,675	15-900	18-720	FA 40	FA 40
W/MG07	8.00	203	-	-	70,000	94,910	45-900	45-720	FA 18	FA 18

## Model 500 Number Codes and Selection Standard (Model 500 Discontinued)

Model 500 Series electric actuator model numbers are coded ten (10) digit alpha-numeric, to describe basic actuator features for computer-assisted order entry system. The first six (6) digits allow computerized material control of basic components including application, motor, motor gears, electric worm gear ratio. The seventh digit (to the right of the second dash) is for electric actuator power voltage provided at job site by user for actuator motor. The eighth digit is for special services. The ninth digit is for auxiliary gearbox gear type (auxiliary gearboxes are optional). The tenth digit is for auxiliary gearbox gear size and ratio. Model number selection charts are based on actuator ratings at power voltage listed. Torques shown for run (ft-lb) can be maintained for 15 minute duty before motor or gearbox overheats. Model number for other voltage is obtained by seventh digit modification (see voltage modifier factor chart). For other load conditions contact Bettis for application assistance.

500	-	C	L	A	-	3	0	2	A
3 <sup>rd</sup> digit Application	4 <sup>th</sup> digit Motor Size	5 <sup>th</sup> digit Motor Gear Ratio	6 <sup>th</sup> digit Electric Worm Gear	7 <sup>th</sup> digit Power Supply	8 <sup>th</sup> digit Special Services	For Auxiliary Gearboxes Only			
9 <sup>th</sup> digit Gear Type	10 <sup>th</sup> digit Gear Size and Ratio								
<b>Multi-turn torque &amp; thrust</b> 0  <b>Torque Only</b> 1	<b>AC Motors</b> 4 Pole  A 400 Watts (1/4 HP) B 60 Watts (1/12 HP) C 120 Watts (1/6 HP)  <b>AC Motors</b> 2 Pole  D 820 Watts (1/4 HP) E 60 Watts (1/12 HP) F 120 Watts (1/6 HP)  <b>DC Motors</b> G 15 Watts (1/50 HP) H 60 Watts (1/12 HP) J 90 Watts (1/8 HP) K 120 Watts (1/6 HP)	<b>2<sup>nd</sup> Stage Reduction Gear Ratio</b> A 4.00 B 3.65 C 3.33 D 3.04 E 2.78 F 2.55 G 2.33 H 2.14  <b>Single Stage Reduction Gear Ratio</b> J 2.00 K 1.82 L 1.67 M 1.53 N 1.40 O 1.29 P 1.18 Q 1.09 R 1.00 S 0.85 T 0.78 U 0.71 V 0.66 W 0.60 Y 0.55 Z 0.50	<b>Gear Ratio</b> A 36  B 18  C 12  D 9  E 7.2	<b>Volts    Φ    Hz</b> 1 208AC    3    60 2 230AC    3    60 3 460AC    3    60 T 460AC    3    50 4 575AC    3    60 5 380AC    3    50 N 380AC    3    60 6 115AC    1    60 7 208AC    1    60 8 230AC    1    60 9 415AC    3    50 K 220AC    1    50 P 220AC    3    50 L 115AC    1    50 R 550AC    3    50 A 400AC    3    50  <b>DC Motors</b> E 24 DC F 48 DC G 90 DC H 125 DC	0 None  1 Cathodic  C Ceramic  F Fireproof  G Gearbox Purchased Direct  H Ceramic Coating With Gearbox  N Special Motors  Q 9:1 GGM Gearbox	0 KWG Worm Gear (Special)  2 KWG Worm Gear (Bronze W.G.)  3 KWG Worm Gear (Ductile Iron W.G.)  4 KBG Bevel Gear  8 KWG Worm Gear (90°)  A KWG Worm Gear Traveling Nut (Bronze W.G.)  B KWG Worm Gear Traveling Nut (Ductile Iron W.G.)	<b>KWG Worm Gear Size Ratio</b> 9 KWG-00M    40 A KWG-01M    44 C KWG-02M    48 8 KWG-01-1SM    88 D KWG-02-1SM    120 F KWG-03-1SM    132 7 KWG-04-1SDM    504 J KWG-35-1SM    132		

KBG Bevel Gear Size Ratio	
A KBG-V0M	3.25
B KBG-V1M	3.50
C KBG-V2M	4.00
D KBG-V3M	5.00
E KBG-V35M	5.50
F KBG-V4M	6.00

# TEC2 Wiring Diagrams (A)

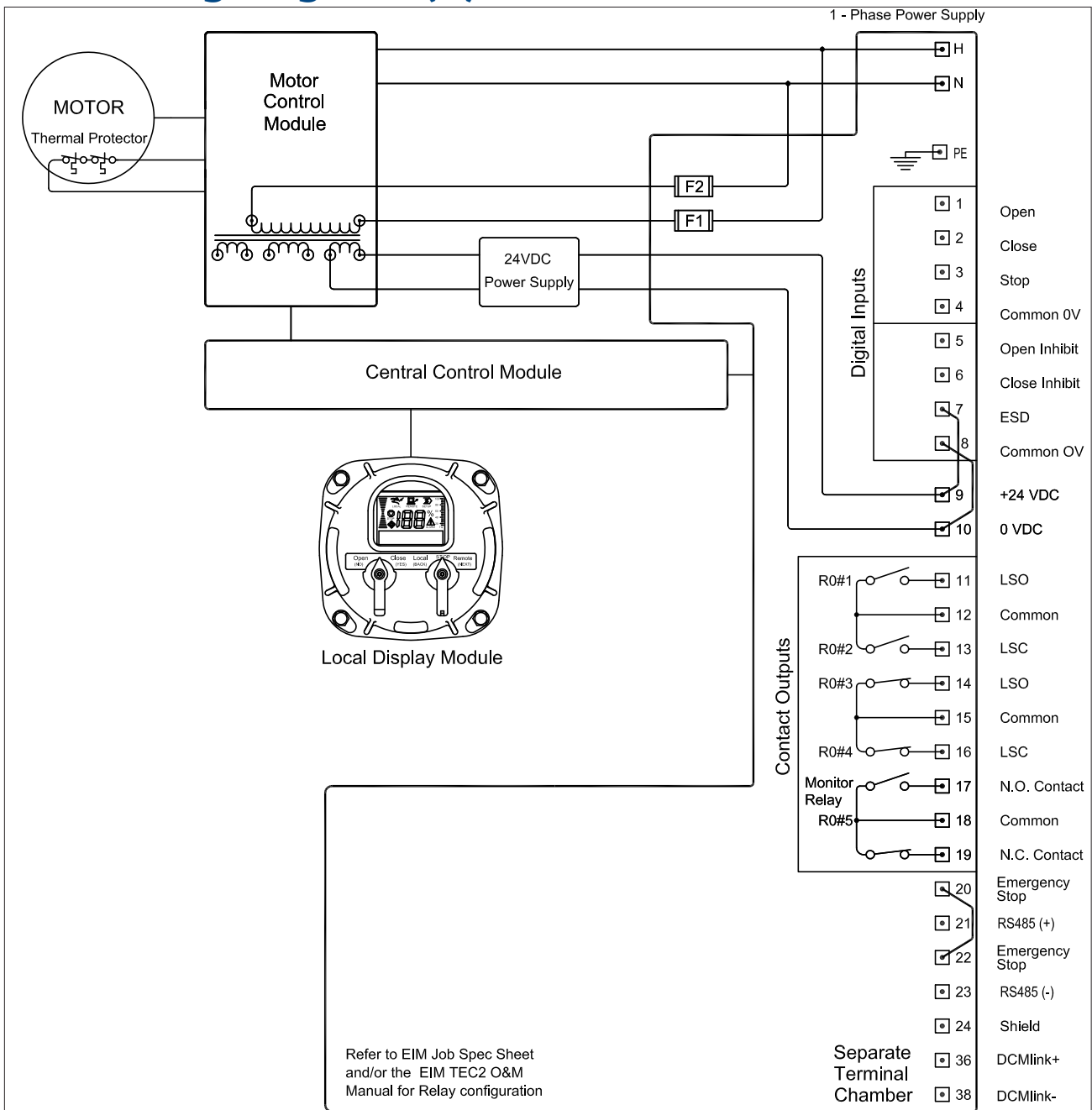

Refer to EIM Job Spec Sheet  
and/or the EIM TEC2 O&M  
Manual for Relay configuration

ARM	CCM	DBM	LDM	MCM	RDM	STC
00	01	00	01	01	00	01

- NOTES:
- 1) All digital inputs have an input voltage range of 18-150 VDC or 20-250 VAC.
  - 2) All digital relay outputs are rated for 5A @ 30 VDC or 5A @ 250 VAC Resistive, 2A Inductive load.
  - 3) Jumpers shown connected between terminals are permissible but not required.
  - 4) Emergency stop requires jumper or normally closed contact (actuator stops when contact open).
  - 5) Remote display communication port is RS-485.
  - 6) If bare wires (without terminals) are connected, remove a maximum of .25 inch insulation.
  - 7) User replaceable primary fuses (F1 and F2) are located in the Terminal Chamber Enclosure. All transformer secondary fuses are automatic resetting.
  - 8) Contact Outputs and Output Switch Contact Development Chart shown for default configuration only. User may redefine all Outputs (See TEC2 Installation & Operation Manual).

	Valve Position			Contact Function
	Close	MID	Open	
LSO				Open Limit
LSC				Close Limit
LSA				Open Limit
LSB				Close Limit

**EMERSON**  
Process Management

DWN BY DJG ORIGINAL DATE 11-19-14  
WIRING DIAGRAM **TEC2 1-PH**

## TEC2 Wiring Diagrams (B)

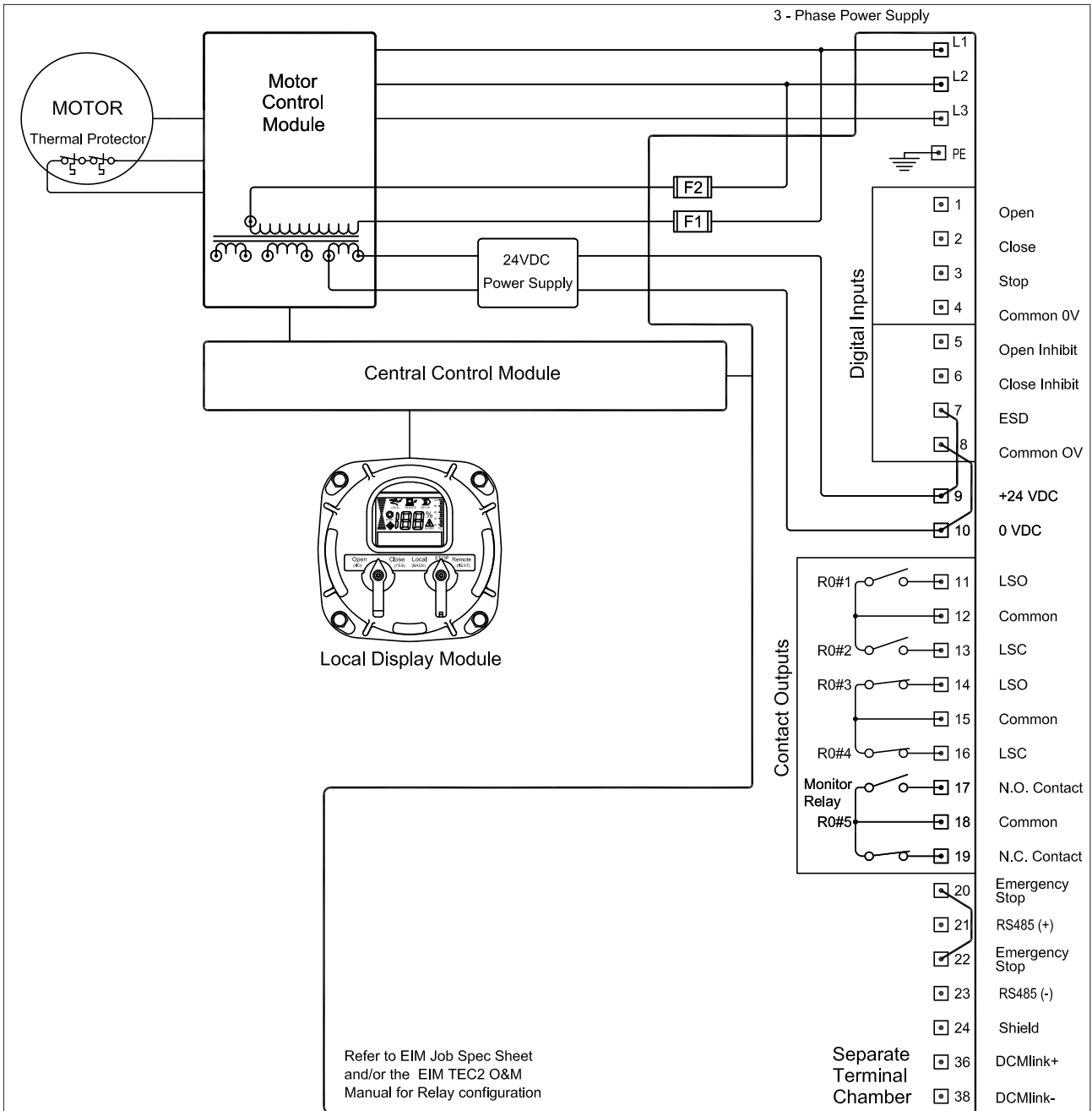

ARM	CCM	DBM	LDM	MCM	RDM	STC
00	01	00	01	02	00	01

- NOTES: 1) All digital inputs have an input voltage range of 18-150 VDC or 20-250 VAC.  
 2) All digital relay outputs are rated for 5A @ 30 VDC or 5A @ 250 VAC Resistive, 2A Inductive load.  
 3) Jumpers shown connected between terminals are permissible but not required.  
 4) Emergency stop requires jumper or normally closed contact (actuator stops when contact open).  
 5) Remote display communication port is RS-485.  
 6) If bare wires (without terminals) are connected, remove a maximum of .25 inch insulation.  
 7) User replaceable primary fuses (F1 and F2) are located in the Terminal Chamber Enclosure. All transformer secondary fuses are automatic resetting.  
 8) Contact Outputs and Output Switch Contact Development Chart shown for default configuration only. User may redefine all Outputs (See TEC2 Installation & Operation Manual).

	Output Switch Contact Development			Contact Function
	Close	MID	Open	
LSO				Open Limit
LSC				Close Limit
LSA				Open Limit
LSB				Close Limit

**EMERSON**  
Process Management

DWN BY: DJG ORIGINAL DATE: 11-19-14

WIRING DIAGRAM **TEC2 3-PH**

## Model 500 Wiring Diagrams (A) (Model 500 Discontinued)

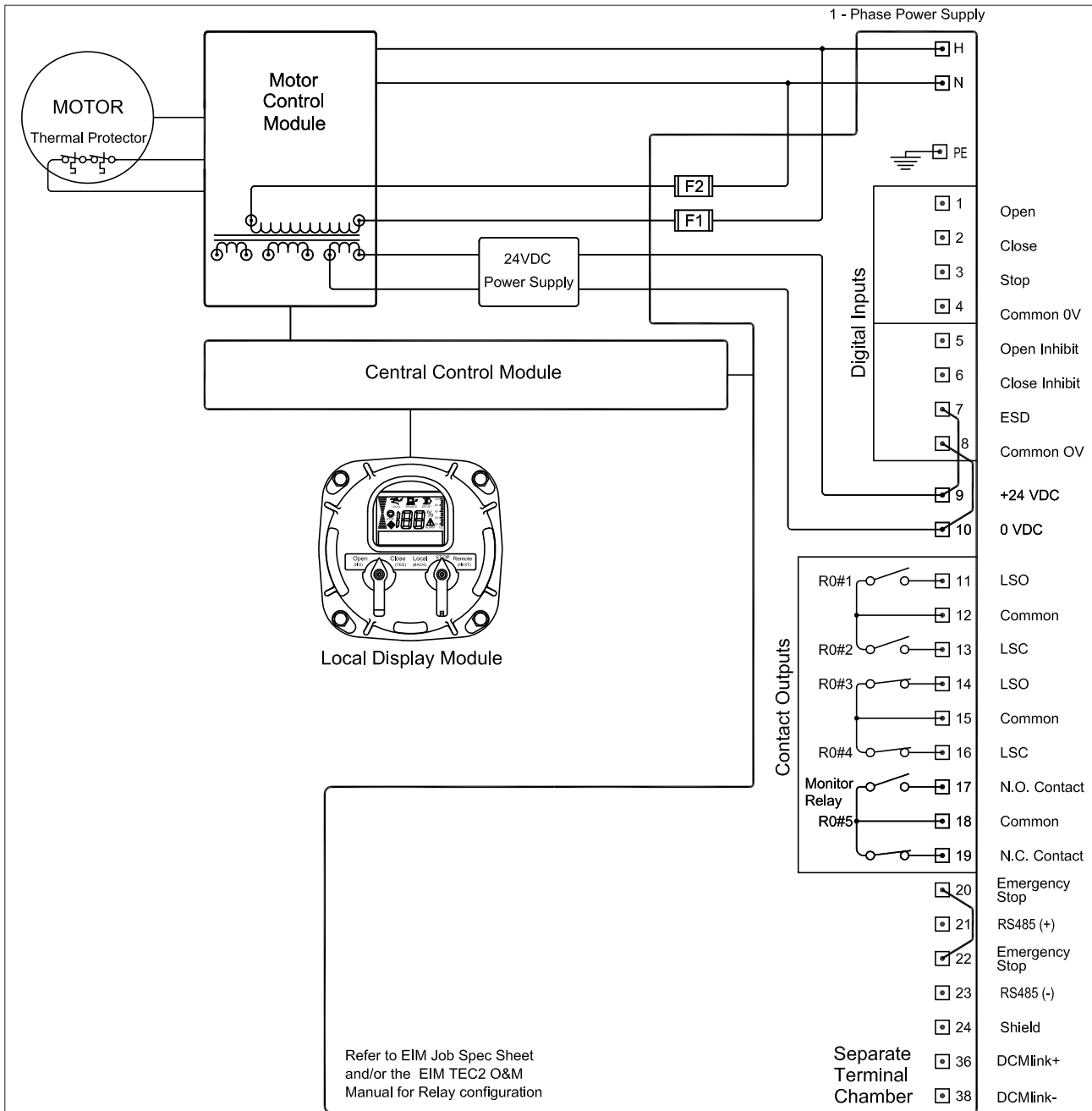

ARM	CCM	DBM	LDM	MCM	RDM	STC
00	01	00	01	01	00	01

- NOTES:
- 1) All digital inputs have an input voltage range of 18-150 VDC or 20-250 VAC.
  - 2) All digital relay outputs are rated for 5A @ 30 VDC or 5A @ 250 VAC Resistive, 2A Inductive load.
  - 3) Jumpers shown connected between terminals are permissible but not required.
  - 4) Emergency stop requires jumper or normally closed contact (actuator stops when contact open).
  - 5) Remote display communication port is RS-485.
  - 6) If bare wires (without terminals) are connected, remove a maximum of .25 inch insulation.
  - 7) User replaceable primary fuses (F1 and F2) are located in the Terminal Chamber Enclosure. All transformer secondary fuses are automatic resetting.
  - 8) Contact Outputs and Output Switch Contact Development Chart shown for default configuration only. User may redefine all Outputs (See TEC2 Installation & Operation Manual).

	Valve Position			Contact Function
	Close	MID	Open	
LSO				Open Limit
LSC				Close Limit
LSA				Open Limit
LSB				Close Limit

**EMERSON**  
Process Management

DWN BY DJG ORIGINAL DATE 11-19-14

WIRING DIAGRAM **Model 500**

# Model 500 Wiring Diagrams (B) (Model 500 Discontinued)

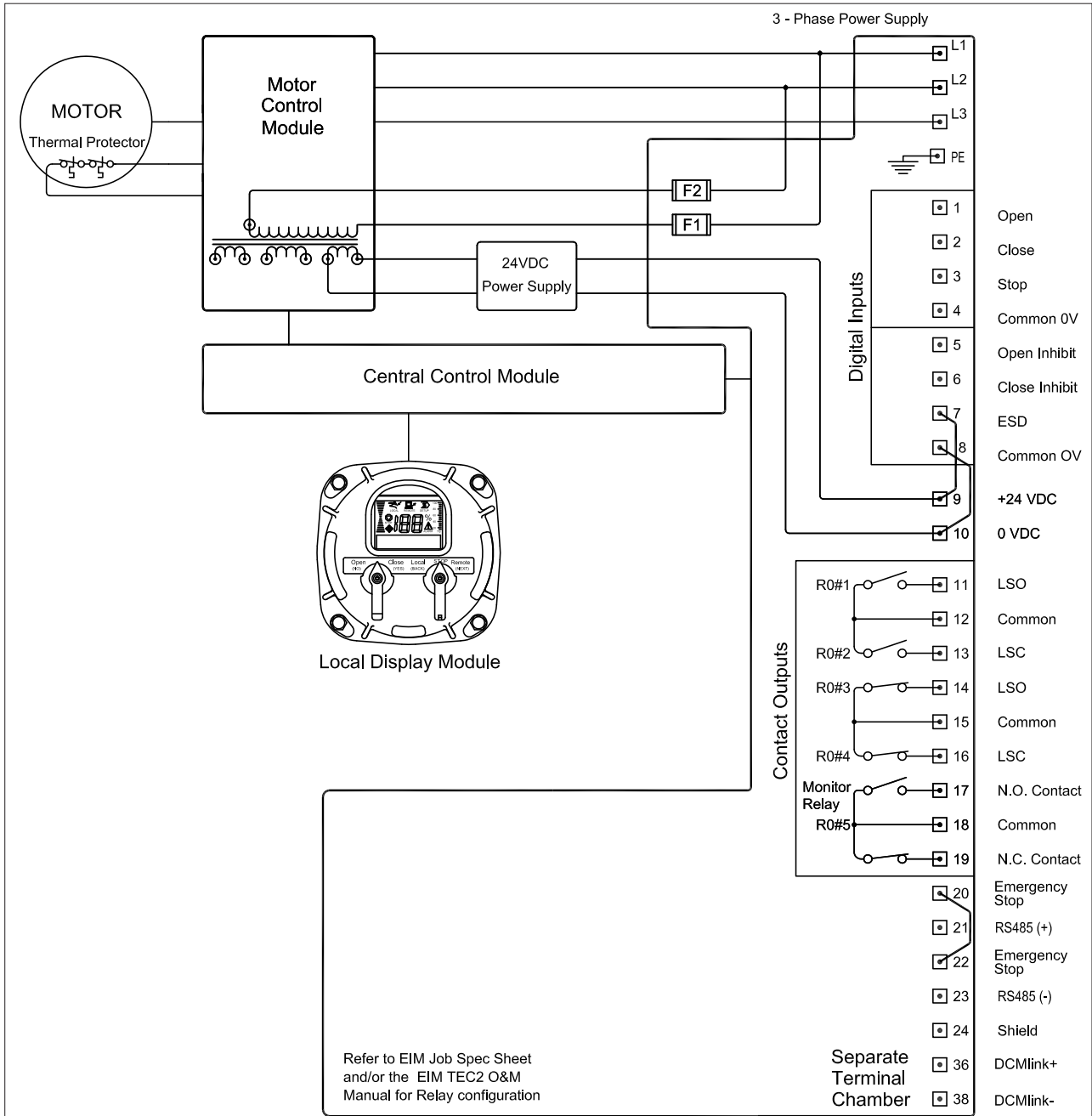

ARM	CCM	DBM	LDM	MCM	RDM	STC
00	01	00	01	02	00	01

- NOTES:
- 1) All digital inputs have an input voltage range of 18-150 VDC or 20-250 VAC.
  - 2) All digital relay outputs are rated for 5A @ 30 VDC or 5A @ 250 VAC Resistive, 2A Inductive load.
  - 3) Jumpers shown connected between terminals are permissible but not required.
  - 4) Emergency stop requires jumper or normally closed contact (actuator stops when contact open).
  - 5) Remote display communication port is RS-485.
  - 6) If bare wires (without terminals) are connected, remove a maximum of .25 inch insulation.
  - 7) User replaceable primary fuses (F1 and F2) are located in the Terminal Chamber Enclosure. All transformer secondary fuses are automatic resetting.
  - 8) Contact Outputs and Output Switch Contact Development Chart shown for default configuration only. User may redefine all Outputs (See TEC2 Installation & Operation Manual).

	Valve Position			Contact Function
	Close	MID	Open	
LSO				Open Limit
LSC				Close Limit
LSA				Open Limit
LSB				Close Limit

**EMERSON**  
Process Management

OWN BY: DJG ORIGINAL DATE: 11-19-14

WIRING DIAGRAM **Model 500**

# Model 500 Drawings (A) (Model 500 Discontinued)

REV	EON	DATE
00	Released	11/4/2014

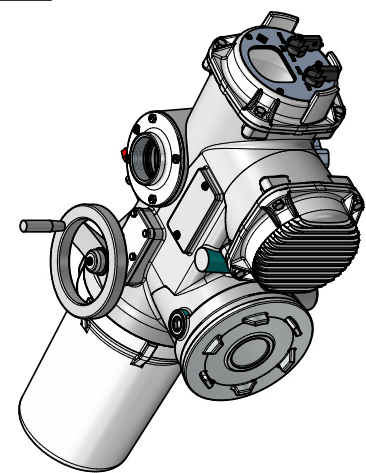
**LDM Cover may be rotated 90°, 180° or 270° as required in field**

**WARNING:** The installation and servicing instructions are for use for qualified personnel only. To avoid injury and electric shock, do not perform any services on Bettis Equipment unless qualified.

Installation shall be accordance with current edition of National Electrical Code or Applicable Regional Standard.

**NOTES:**

- Customer Wire entry to STC Separate Terminal Chamber. Conduit should always enter from below STC if possible.
- Lubrication 1/2" NPT plugs.
- Lubrication 1/8" NPT plug.
- To move actuator to another valve, bronze stem nut P/N 38244 may be threaded up to 1.57" max. (Ref Dwg 90719 for details).

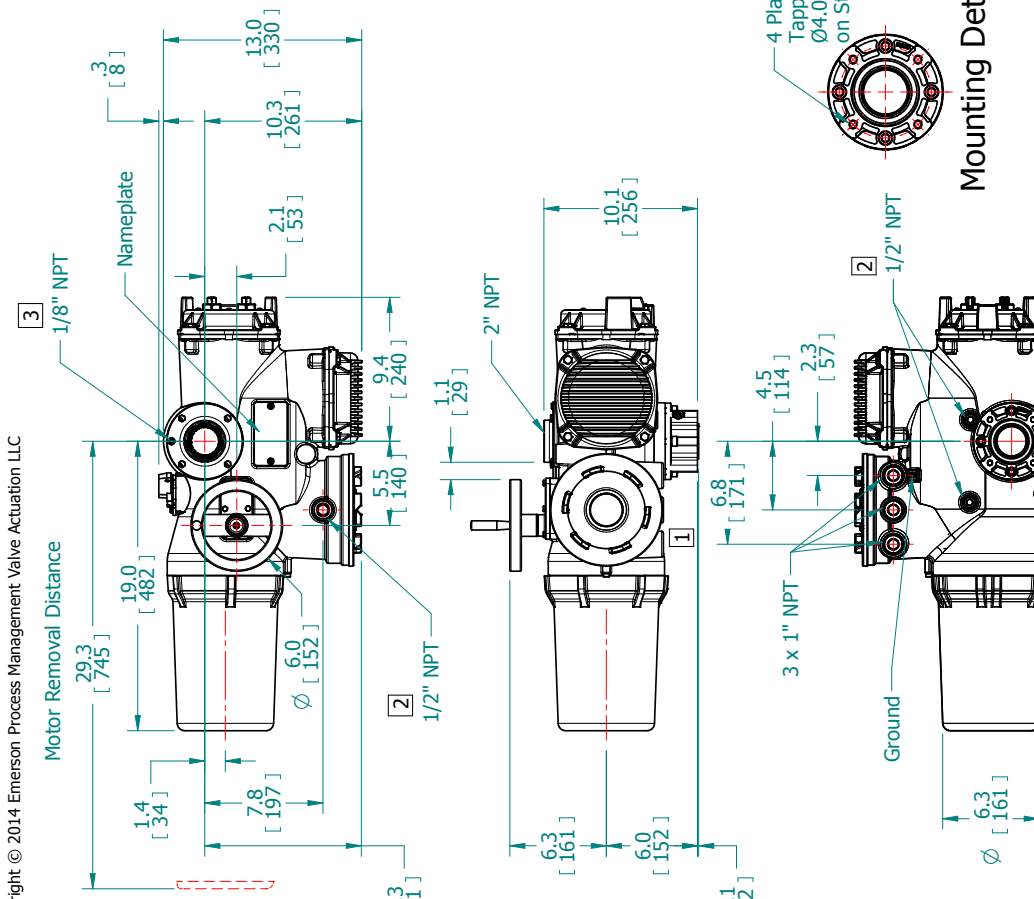
**Mounting Detail**

4 Places Tapped 3/8-16 UNC-2B  $\nabla$ .80  $\varnothing$ 4.000 (102) B.C on Straddle Centerline

**TITLE:**  
Model 500 Standard  
33 Frm Motor w/TB FA10

INTERPRET DIMENSIONS AND TOLERANCE PER ASME Y14.5  
THIRD ANGLE PROJECTION APPROXIMATE WEIGHT .0 lbm

**EMERSON**  
Process Management  
**500-TB00/10V**

DRAWING NO. 500-TB00/10V  
DRAWN BY Ryan Hoang  
CHECKED BY Josh Johnson  
APPROVED BY Doyle Blume  
DATE 11/4/2014  
SCALE: 1:5 DWG. SIZE: A2 SHEET: 1 of 1 REV. 00

**CONFIDENTIAL:** This drawing, including the information it bears, is the property of Emerson Process Management Valve Actuation LLC and must be held in strict confidence and properly safeguarded by the recipient at all times. It may not be copied or reproduced, or provided or revealed to any other party except with the prior written authorization of Emerson Process Management Valve Actuation LLC and any authorized copy or reproduction must include this legend. The recipient may use the same only for the purpose for which Emerson Process Management Valve Actuation LLC has provided it to recipient, and it must be returned to Emerson Process Management Valve Actuation LLC, along with all copies and reproductions, upon request. By accepting this drawing, the recipient agrees to the foregoing.

# Model 500 Drawings (B) (Model 500 Discontinued)

REVISIONS		
REV	ECN	DATE
00	Released	11/4/2014

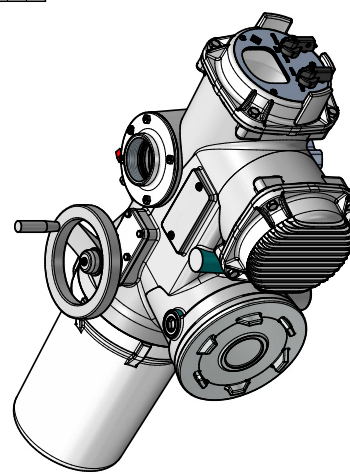

LDM Cover may be rotated 90°, 180° or 270° as required in field

**WARNING:** The installation and servicing instructions are for use for qualified personnel only. To avoid injury and electric shock, do not perform any services on Bettis Equipment unless qualified.

Installation shall be accordance with current edition of National Electrical Code or Applicable Regional Standard.

**NOTES:**

- Customer Wire entry to STC Separate Terminal Chamber. Conduit should always enter from below STC if possible.
- Lubrication 1/2" NPT plugs.
- Lubrication 1/8" NPT plug.
- To move actuator to another valve, bronze stem nut P/N 38244 may be threaded up to 1.57" max. (Ref Dwg 90719 for details).

**Mounting Detail**

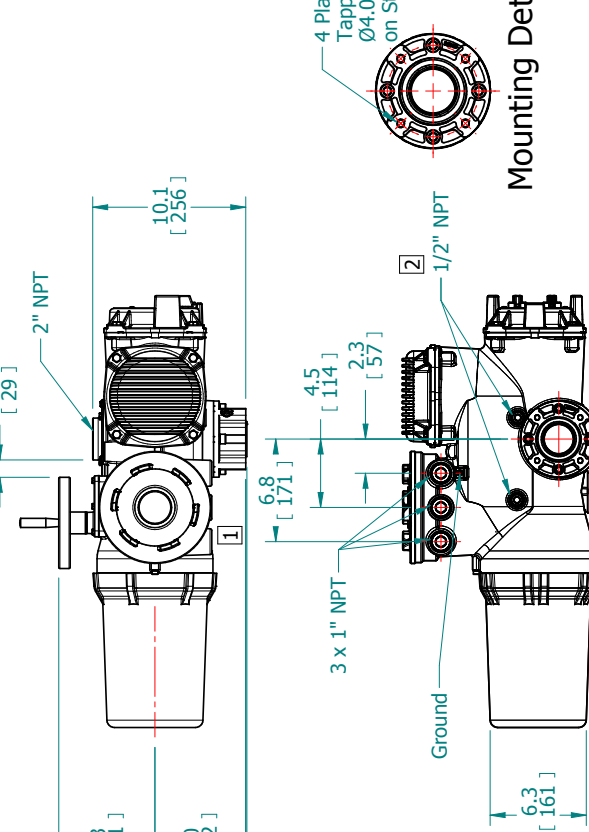

4 Places Tapped 3/8-16 UNC-2B  $\nabla$ .80  $\varnothing$ 4.000 (102) B.C on Straddle Centerline

3 x 1" NPT

Ground

1/2" NPT

1/2" NPT

**Model 500 Standard**  
42 Fm Motor w/TB FA10

EMERSON  
Process Management

DRAWING NO. 500-TB0710V

DRWN BY Ryan Hoang  
CHECKED BY Josh Johnson  
SCALE: 1:5  
DWG. SIZE: A2  
SHEET 1 OF 1

APPROVED BY: Doyle Blume  
DATE: 11/4/2014  
REV. 00

**INTERPRET DIMENSIONS AND TOLERANCE PER ASME Y14.5**

THIRD ANGLE PROJECTION

APPROXIMATE WEIGHT .0 lbm

**CONFIDENTIAL:** This drawing, including the information it bears, is the property of Emerson Process Management Valve Actuation LLC and must be held in strict confidence and properly safeguarded by the recipient at all times. It may not be copied or reproduced, or provided or revealed to any other party except with the prior-written authorization of Emerson Process Management Valve Actuation LLC and any authorized copy or reproduction must include this legend. The recipient may use the same only for the purpose for which Emerson Process Management Valve Actuation LLC has provided it to recipient, and it must be returned to Emerson Process Management Valve Actuation LLC, along with all copies and reproductions, upon request. By accepting this drawing, the recipient agrees to the foregoing.



**World Area Configuration Centers (WACC) offer sales support, service, inventory and commissioning to our global customers.**

**Choose the WACC or sales office nearest you:**

***NORTH & SOUTH AMERICA***

19200 Northwest Freeway  
Houston TX 77065  
USA  
T +1 281 477 4100

Av. Hollingsworth  
325 Iporanga Sorocaba  
SP 18087-105  
Brazil  
T +55 15 3413 8888

***ASIA PACIFIC***

No. 9 Gul Road  
#01-02 Singapore 629361  
T +65 6777 8211

No. 1 Lai Yuan Road  
Wuqing Development Area  
Tianjin 301700  
P. R. China  
T +86 22 8212 3300

***MIDDLE EAST & AFRICA***

P. O. Box 17033  
Jebel Ali Free Zone  
Dubai  
T +971 4 811 8100

P. O. Box 10305  
Jubail 31961  
Saudi Arabia  
T +966 3 340 8650

24 Angus Crescent  
Longmeadow Business Estate East  
P.O. Box 6908 Greenstone  
1616 Modderfontein Extension 5  
South Africa  
T +27 11 451 3700

***EUROPE***

Holland Fasor 6  
Székesfehérvár 8000  
Hungary  
T +36 22 53 09 50

Strada Biffi 165  
29017 Fiorenzuola d'Arda (PC)  
Italy  
T +39 0523 944 411

For complete list of sales and manufacturing sites, please visit [www.emerson.com/actuationtechnologieslocations](http://www.emerson.com/actuationtechnologieslocations) or contact us at [info.actuationtechnologies@emerson.com](mailto:info.actuationtechnologies@emerson.com)

[www.emerson.com/bettis](http://www.emerson.com/bettis)

©2018 Emerson. All rights reserved.

The Emerson logo is a trademark and service mark of Emerson Electric Co. Bettis™ is a mark of one of the Emerson family of companies. All other marks are property of their respective owners.

The contents of this publication are presented for information purposes only, and while every effort has been made to ensure their accuracy, they are not to be construed as warranties or guarantees, express or implied, regarding the products or services described herein or their use or applicability. All sales are governed by our terms and conditions, which are available on request. We reserve the right to modify or improve the designs or specifications of our products at any time without notice.

**BETTIS™**

