

# Safe and Efficient Gas Pipeline Control



**Bettis GH-Series Gas/Hydraulic Valve Operators**  
Controls high pressure natural gas pipelines in remote locations and under severe climatic conditions



## Design and Construction

Emerson – Actuation Technologies is recognized worldwide for the reliability of its actuators under the most demanding conditions. The gas/hydraulic products epitomize the quality and performance required for controlling high pressure natural gas pipelines in remote locations and under severe climatic conditions.

Bettis™ gas/hydraulic actuators are used to automate valves located on gas transmission pipelines, often travelling hundreds of miles through inhospitable areas where there are no low pressure instrument air or high pressure hydraulic supply lines available. Bettis actuators are available in either rotary, quarter-turn models or in linear models.

The gas/hydraulic actuators operate using pressurized gas from the pipeline as its power source, requiring reliability and safety features built into the valve operator system. Since the line gas is a potential hazard, Bettis actuators use a clean, non-explosive hydraulic fluid as an oil barrier rather than direct line gas.

### Features and Benefits

- High Pressure - Uses a high pressure gas supply (typically from gas pipeline) as power source.
- Excellent sealing – All models have zero leak pistons and rod seals with materials selected to suit application .
- High torques and thrusts – Rotary quarter-turn models have torques to 6,000,000 lb. in (678,000 Nm) and linear models with thrusts up to 650,000 lbs (2,891,200 N).
- Adaptability – Adaptable for all types of gas compositions including sour (NACE) and wet gas.
- Aluminum alloy actuator body and controls - – For exceptional corrosion resistance and low temperature applications.
- Many control system options - including remote control, high/low shutoff and linebreak.
- Hydraulic hand pump for emergency operation.
- Piston with non-metallic wear ring to prevent piston/cylinder scuffing.
- Reliable tanks – Bettis actuators use pressure vessels manufactured and certified (U stamp) to ASME Section VIII as standard.
- Standard operating temperature is -50°F to 150°F (-46°C to + 66°C).
- Standard operating pressure to 1,440 PSIG.



*Bettis has been a global leader in valve control for high pressure natural gas operation for more than 55 years.*

*Bettis gas/hydraulic valve operators have proven themselves as a safe means of valve control in any climate or terrain, from remote desert to arctic conditions.*

*Torques of up to 6,000,000 lb in and thrusts to 650,000 lbs provide the reliability for operating at the highest pipeline pressure.*



# Assembly and Features

## Bettis GH-Series I

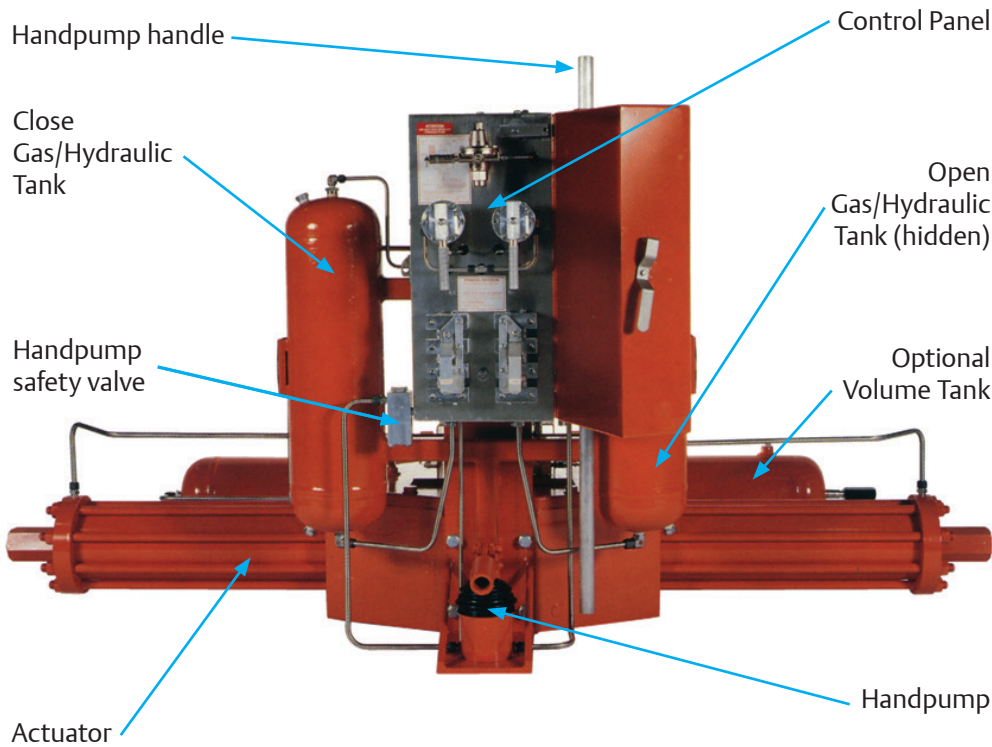

Incorporates a scotch-yoke design for converting linear motion to rotary motion, with breakaway torques from 5,000(565 Nm) to 6,000,000 lb. in (678,000 Nm).

- Readily adaptable for all quarter-turn valves, 90° +/- 10° adjustable rotation standard, limited rotation available.
- Standard light weight cast aluminum drive cases. Optional ductile iron or cast steel cases available.
- Replaceable top and bottom yoke bearings.
- Torque limiting devices available
- Integral drive rod deflection stabilizers to absorb side loads.
- Visual valve position indication
- Readily adaptable for fail safe operation.

## Bettis GH-Series II

- Incorporates a scotch-yoke design for converting motion to rotary motion, with breakaway torques from 500 Nm (4,400 lb.in) to 160,000 Nm (1,400,000 lb.in)
- Readily adaptable for all quarter-turn valves, 90° ± 10° adjustable rotation standard, limited rotation available.
- Ductile iron drive case.
- Replaceable top and bottom yoke bearings.
- Visual valve position indication.
- Readily adaptable for fail safe operation.

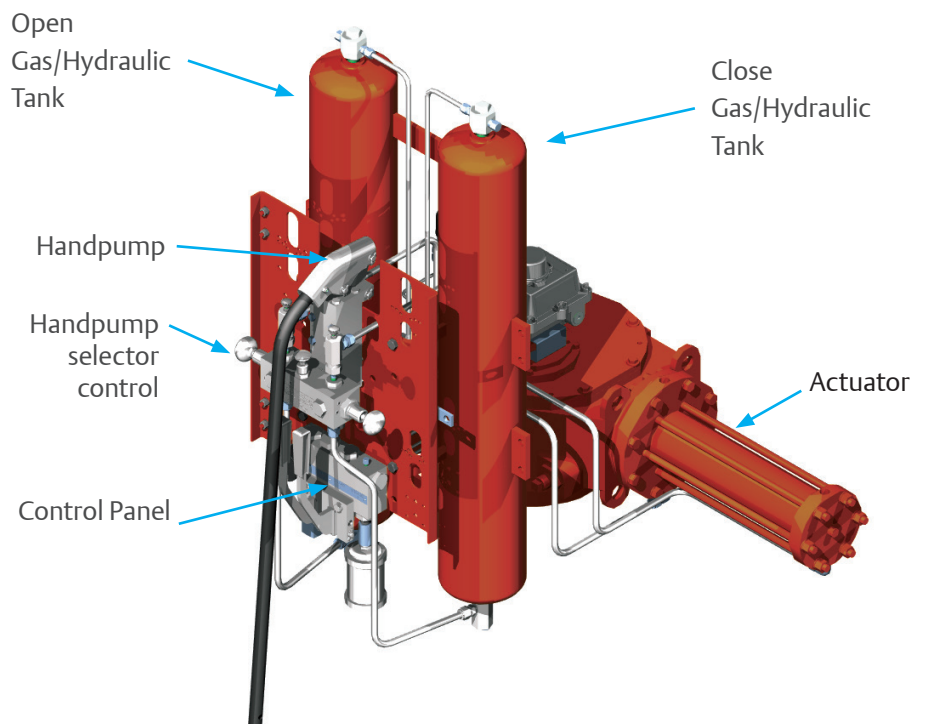

# Control Schematics (Quarter-turn Operator shown)

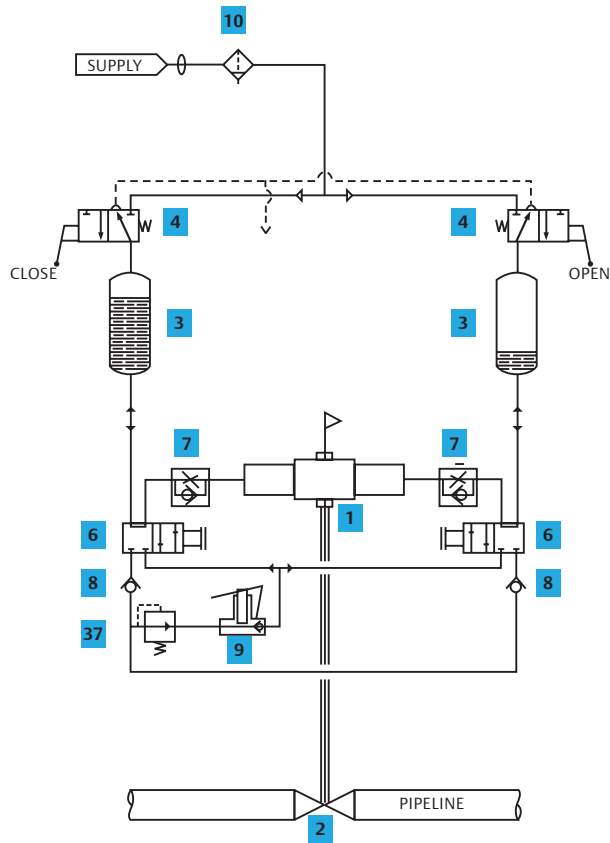

## Typical Control Schematics for Two-Way Manual Operation

Operations:

- Operate 3-way valve (4) to open or close with power gas
- Operate selector valve (6) to enable respective handpump direction

Other control arrangements are available to suit customer applications. For example:

- Line break detection
- Fail close/open by remote signal
- Energize to open, manual close
- Energize to close, manual reset to open

## Component List

Manual Operation

- |                       |                          |
|-----------------------|--------------------------|
| 1 Operator            | 7 Speed Control Valve    |
| 2 Line Valve          | 8 Check Valve            |
| 3 Gas/Hydraulic Tank  | 9 Handpump               |
| 4 3-Way Valve, Manual | 10 Filter                |
| 6 Selector Valve      | 37 Handpump Safety Valve |

## Legend

- |                  |            |
|------------------|------------|
| Power Gas        | Return     |
| Hydraulic        | Closed     |
| Electrical       | Instrument |
| Field Connection | Vent       |
| Plugged Port     | Open       |
| Signal           |            |

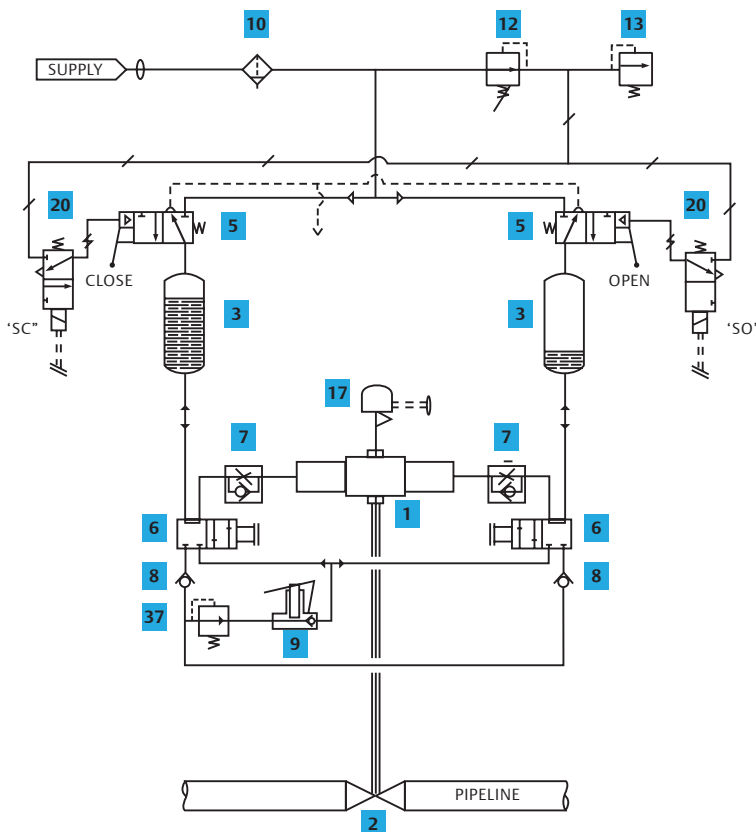

## Typical Control Schematics for Two-Way Electric Operation

Operations:

- Energize solenoid 'SC' to close or "SO" to open
- Solenoids must be de-energized at end of stroke

## Component List

Electric Operation

- |                             |                          |
|-----------------------------|--------------------------|
| 1 Operator                  | 9 Handpump               |
| 2 Line Valve                | 10 Filter                |
| 3 Gas/Hydraulic Tank        | 12 Regulator             |
| 5 3-Way Valve, Manual/Pilot | 13 Relief Valve          |
| 6 Selector Valve            | 17 Limit Switch          |
| 7 Speed Control Valve       | 20 Solenoid Valve, N.C.  |
| 8 Check Valve               | 37 Handpump Safety Valve |

# Scotch Yoke Mechanism

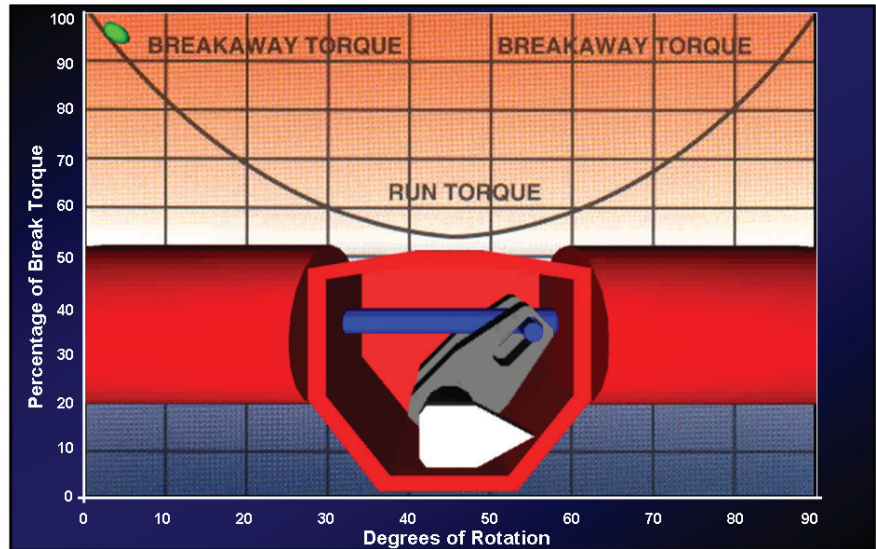

The scotch yoke mechanism for Bettis quarter-turn valve operators produces a torque curve that closely matches the valve actuation requirements when converting linear output into rotary motion. The scotch yoke produces greater torque value at the beginning and end of each stroke of the piston, precisely where it is required to operate most types of valves. The torque outputs produced by double-acting actuators are expressed as breakaway and run torque. The breakaway torque is that produced at the beginning and the end of the scotch yoke rotation. The run torque is that produced at the mid-point (45 degrees) of the scotch yoke rotation.



## Emerson brands for most common control accessories:

- |                                   |                |
|-----------------------------------|----------------|
| <b>Digital Valve Controllers:</b> | Fisher®        |
| <b>Positioners:</b>               | Fisher®        |
| <b>Regulators:</b>                | Fisher®        |
| <b>Switch boxes:</b>              | TopWorx        |
| <b>Wireless position monitor:</b> | TopWorx        |
| <b>Solenoid valves:</b>           | ASCO Numatics™ |

World Area Configuration Centers (WACC) offer sales support, service, inventory and commissioning to our global customers. Choose the WACC or sales office nearest you:

**NORTH & SOUTH AMERICA**

19200 Northwest Freeway  
Houston TX 77065  
USA  
T +1 281 477 4100

Av. Hollingsworth  
325 Iporanga Sorocaba  
SP 18087-105  
Brazil  
T +55 15 3413 8888

**ASIA PACIFIC**

No. 9 Gul Road  
#01-02 Singapore 629361  
T +65 6777 8211

No. 1 Lai Yuan Road  
Wuqing Development Area  
Tianjin 301700  
P. R. China  
T +86 22 8212 3300

**MIDDLE EAST & AFRICA**

P. O. Box 17033  
Jebel Ali Free Zone  
Dubai  
T +971 4 811 8100

P. O. Box 10305  
Jubail 31961  
Saudi Arabia  
T +966 3 340 8650

24 Angus Crescent  
Longmeadow Business Estate East  
P.O. Box 6908 Greenstone  
1616 Modderfontein Extension 5  
South Africa  
T +27 11 451 3700

**EUROPE**

Holland Fasor 6  
Székesfehérvár 8000  
Hungary  
T +36 22 53 09 50

Strada Biffi 165  
29017 Fiorenzuola d'Arda (PC)  
Italy  
T +39 0523 944 411

This product is only intended for use in large-scale fixed installations excluded from the scope of Directive 2011/65/EU on the restriction of the use of certain hazardous substances in electrical and electronic equipment (RoHS 2).

For complete list of sales and manufacturing sites, please visit [www.emerson.com/actuationtechnologieslocations](http://www.emerson.com/actuationtechnologieslocations) or contact us at [info.actuationtechnologies@emerson.com](mailto:info.actuationtechnologies@emerson.com)

©2018 Emerson. All rights reserved.

The Emerson logo is a trademark and service mark of Emerson Electric Co. Bettis™ is a mark of the Emerson family of companies. All other marks are property of their respective owners.